

FT3424 FT3425

HIOKI

照度計 LUX METER

取扱説明書
Instruction Manual



動画はこちらから▶

スキャンすると使い方の動画を見ることができます。
*通信料金はおお客様のご負担となります。



JA/EN

June 2019 Revised edition 6
FT3424A980-06 19-06H



* 6 0 0 4 2 8 5 6 6 *

HIOKI FT3424A980-06

1.800.561.8187

www.itm.com

information@itm.com

FT3424

FT3425

LUX METER

HIOKI

Instruction Manual

Video

Scan this code to watch an instructional video.

Carrier charges may apply.



EN

June 2019 Revised edition 6
FT3424A980-06 19-06H

Contents

Introduction.....	1
Verifying Package Contents	2
Options (Sold Separately).....	3
Safety Notes.....	5
Usage Notes.....	8

1 Overview **13**

1.1 Overview and Features.....	13
1.2 Parts Names and Functions.....	14
1.3 LCD.....	19

2 Measurement Methods **23**

2.1 Measurement Workflow.....	23
2.2 Inserting/Replacing Batteries	24
2.3 Attaching the Strap.....	26
2.4 Inspection Before Use	28
2.5 Making Measurements.....	29
2.6 Selecting the Measurement Range.....	33

3 Applied Functionality **35**

3.1 Retaining the Measured Value after a Set Amount of Time (Timer Hold Function).....	35
Retaining the measured value (TIMER)	35
3.2 Undocking the Display Unit and Sensor Unit	37
3.3 Mounting the Sensor Unit on a Tripod or Monopod	38
3.4 Using the Z5023 Extension Cart	39



3.5	Limiting Battery Consumption (Auto Power OFF Function)	42
3.6	Saving Measured Values (Memory Function)	44
	Saving the measured value (MEM)	44
	Reading the saved measured values (READ)	45
	Deleting the most recently saved measured value (CLEAR).....	46
	Deleting all the saved measured values	46
3.7	Logging Illuminance Data (Output Function)	47
3.8	Communicating with the PC	49
3.9	Communicating with a Smart Phone or Tablet (FT3425 only)	51
	Installing the smartphone application	53
	Pairing the application with the lux meter (FT3425) .	54
	Making measurements with the Bluetooth function ..	55
3.10	Disabling the Buzzer	56
3.11	Turning On the Backlight	57
4	Specifications	59
4.1	Basic Specifications	59
4.2	Measurement Specifications	60
	Accuracy	60
	Characteristics	61
4.3	Output Specifications	62
4.4	Functional Specifications	63
4.5	General Specifications	64
4.6	Bluetooth Communication Specifications (FT3425 only)	66
5	Maintenance and Service	67

5.1	Repair, Inspection, and Cleaning.....	67
5.2	Troubleshooting	68
5.3	Error Display.....	70
5.4	Display Messages	71

Appendix **Appx.1**

Appx. 1	Recommended Levels of Illumination (Reference).....	Appx.1
Appx. 2	Sensor Characteristics Graphs	Appx.3
	Relative Spectral Response Characteristics in the Visible Spectrum	Appx.3
	Angled Incident Light Characteristics	Appx.4
Appx. 3	Other Characteristics	Appx.5
Appx. 4	Dimensional Drawings	Appx.6

Warranty Certificate	WTY1
----------------------------	------



Introduction

Thank you for purchasing the HIOKI FT3424, FT3425 Lux Meter. To obtain maximum performance from the product, please read this manual first, and keep it handy for future reference.

Only the FT3425 has the **Bluetooth®** communication function. Using this function enables smart phones and tablets to view and record measurement data.

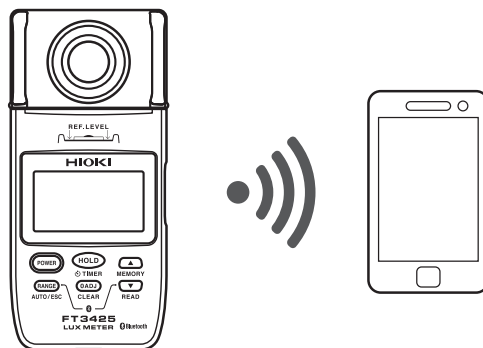

Trademarks

- Bluetooth® is a registered trademark of BluetoothSIG, Inc.(USA). The trademark is used by HIOKI E.E. CORPORATION under license.
- Android and Google Play are trademarks of Google, Inc.
- IOS is a registered trademark of Cisco Systems, Inc. and/or its affiliates in the United States and certain other countries.
- iPhone, iPad, iPad mini™, iPad Pro, and iPod Touch are trademarks of Apple Inc.
- The App Store is a service mark of Apple Inc.

Verifying Package Contents

When you receive the instrument, inspect it carefully to ensure that no damage occurred during shipping.

In particular, check the accessories, operation keys of the panel, and connectors. If damage is evident, or if it fails to operate according to the specifications, contact your authorized Hioki distributor or reseller.

Check the package contents as follows.

- FT3424 or FT3425

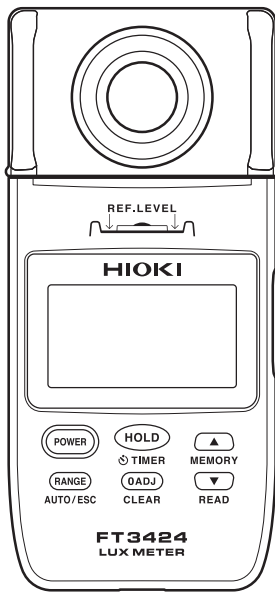

- LR6 Alkaline battery × 2



- Carrying case (soft)

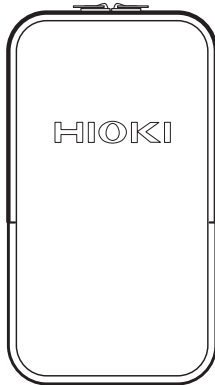

- Strap (for the instrument) (p.26)



- Sensor cap (with the strap) (p.29)

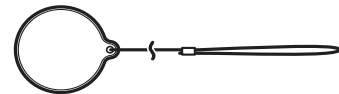

- Instruction manual
- Precautions concerning use of equipment that emits radio waves (FT3425 only)

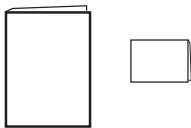

- CD* (USB driver, dedicated computer application software, and communications specifications)

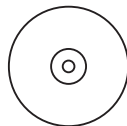

- USB cable (Length: 0.9 m)



* The latest version can be downloaded from our web site.

Options (Sold Separately)

The following options are available for the instrument.
Contact your authorized Hioki distributor or reseller when ordering.
The options are subject to change. Visit our website for updated information.

Connection cable

Use when positioning the sensor unit and display unit separately during use.

L9820 Connection Cable

(Length: 2 m)



Output cords

Required when using the instrument's output functionality.

L9094 Output Cord

(Length: 1.5 m, for use with banana terminals)

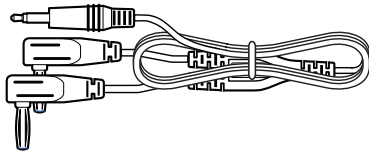

L9095 Output Cord

(Length: 1.5 m, for use with BNC terminals)

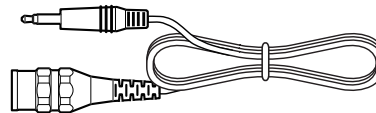

L9096 Output Cord

(Length: 1.5 m, for use with terminal blocks)



Options (Sold Separately)

Carrying cases

Handy for storing the instrument with the L9820 Connection Cable, L9094/L9095/L9096 Output Cord, and USB cable.

C0201 Carrying Case (semi-hard)

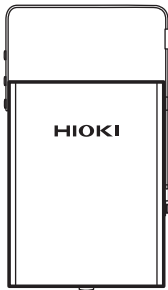

* L9820 Connection Cable cannot be stored.

C0202 Carrying Case (soft)



Measurement aid

Attach the sensor unit or instrument to this convenient cart to measure illuminance on floor surfaces while standing. The cart can be easily moved between measurement locations. In addition, a monopod can be attached to keep height from the floor surface constant.

Model Z5023 Extension Cart

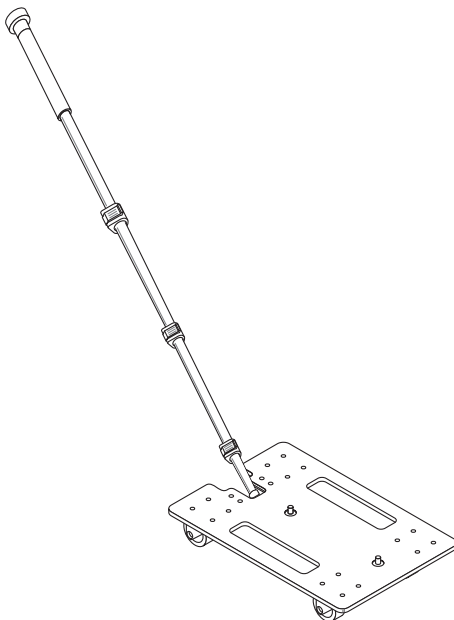

Safety Notes

The instrument is designed to conform to IEC 61010 Safety Standards, and has been thoroughly tested for safety prior to shipment. However, using the instrument in a way not described in this manual may negate the provided safety features.

Before using the instrument, be certain to carefully read the following safety notes.





CAUTION





- Mishandling during use could lead to damage to the instrument. Be certain that you understand the instructions and precautions in the manual before use.
- Individuals using an electrical measuring instrument for the first time should be supervised by a technician who has experience in electrical measurement.

Notation



In this manual, the risk seriousness and the hazard levels are classified as follows.

 WARNING	Indicates a potentially hazardous situation that may result in death or serious injury to the operator.
 CAUTION	Indicates a potentially hazardous situation that may result in minor or moderate injury to the operator or damage to the instrument or malfunction.
IMPORTANT	Indicates information related to the operation of the instrument or maintenance tasks with which the operators must be fully familiar.
	Indicates the prohibited action.
	Indicates the action which must be performed.
*	Additional information is presented below.

Symbols affixed to the instrument

	Indicates cautions and hazards. When the symbol is printed on the instrument, refer to a corresponding topic in the Instruction Manual.
	Indicates DC (Direct Current).
	Indicates that the product incorporates Bluetooth® wireless technology.

Symbols for various standards

	Indicates the Waste Electrical and Electronic Equipment Directive (WEEE Directive) in EU member states.
	Indicates that the instrument conforms to regulations set out by the EU Directive.

Screen display

The screen of the instrument displays characters in the following manner.

A	B	C	D	E	F	G	H	I	J	K	L	M	N	O	P	Q	R	S	T	U	V	W	X	Y	Z
A	b	C	d	E	F	G	H	I	J	K	L	M	N	O	P	Q	R	S	T	U	V	W	X	Y	Z

1	2	3	4	5	6	7	8	9	0
1	2	3	4	5	6	7	8	9	0

Different displays are used in the cases below.

b. Lo

Displays when power is shutdown (p.21)

n.c.

Displays when the display unit and sensor unit are not connected.

Accuracy

We define measurement tolerances in terms of f.s. (full scale), rdg. (reading) and dgt. (digit) values, with the following meanings:

f.s.	(Maximum display value) Indicates the maximum displayable value. This is usually the name of the currently selected range.
rdg.	(Reading value) The value currently being measured and displayed on the measuring instrument.
dgt.	(Resolution) The minimum display unit, indicating a minimum digit of 1.

Usage Notes

Follow these precautions to ensure safe operation and to obtain the full benefits of the various functions.

Before Use

Verify that the instrument operates normally to ensure that no damage occurred during storage or shipping. If you find any damage, contact your authorized Hioki distributor or reseller.

Installation

For details on the operating temperature and humidity, see the specifications.(p.64)

WARNING

Installing the instrument in inappropriate locations may cause a malfunction of instrument or may give rise to an accident. Avoid the following locations.



- **Exposed to high temperature**
- **Exposed to corrosive or combustible gases**
- **Exposed to water, oil, chemicals, or solvents**
- **Exposed to high humidity or condensation**
- **Exposed to high quantities of dust particles**
- **Susceptible to vibration**

When the instrument is not in use, store the instrument in a cool, dark place because optical components are vulnerable to heat.

Handling the cables and cords

CAUTION



- Before use, verify that the insulation on cables and cords is not damaged and that no metal is exposed. If you find any damage, replace the cable or cord with those specified by our company, as the instrument will not be able to make accurate measurements or send/receive data otherwise.



- Avoid stepping on or pinching the cables and cords, which could damage the cable insulation.
- To avoid breaking the base of connectors and jacks, do not bend or pull them.
- Cables and cords become stiff and rigid in freezing temperatures. Exercise caution in such environments as bending or pulling on cables and cords may damage their insulation or cause them to break.

Handling the instrument

CAUTION



- The instrument consists of a sensor unit and a display unit that can be positioned apart from one another during operation. To avoid damage, be sure to turn off the instrument before undocking or docking the sensor and display units.



- To avoid damage to the instrument, protect it from physical shock when transporting and handling. Be especially careful to avoid physical shock from dropping.
- To avoid damage to the instrument, do not short-circuit the D/A OUTPUT terminal and do not input voltage to the D/A OUTPUT terminal.

IMPORTANT

- Use only the specified L9820 Connection Cable when using the display unit and sensor unit separately. Using a non-specified cable may result in incorrect measurements due to poor connection or other reasons.
- When measuring illuminance underneath a standard lighting fixture, the display may not stabilize. In most cases, a failure to stabilize is due to fluctuations in the lighting fixture's supply voltage or to the surrounding environment (for example, a person's shadow). Exercise care concerning these factors when performing measurement.
- The LCD includes a backlight for use when making measurements in dim locations. The backlight will activate automatically when the measured value is retained or when the measured value data stored in the internal memory is in read mode, both in low-light environments (approx. 750 lx or less). To avoid affecting measurement results, the backlight cannot be turned on during measurement.
- The instrument's measurement reference level (**REF.LEVEL**) is the colored part in the drawing below.

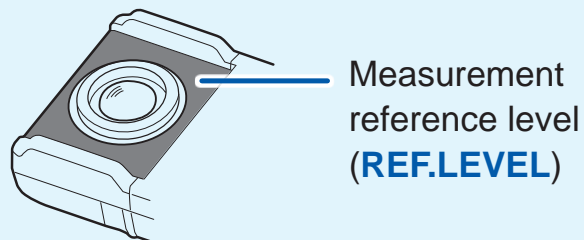

- Do not attempt to disassemble the instrument or subject it to mechanical shock.

CD precautions

- Exercise care to keep the recorded side of the disc free of dirt and scratches. When writing text on the disc's label, use a pen or marker with a soft tip.
- Keep the disc inside a protective case and do not expose to direct sunlight, high temperature, or high humidity.
- Hioki is not liable for any issues your computer system experiences in the course of using this disc.

Precautions during shipment

Observe the following during shipment. Hioki cannot be responsible for damage that occurs during shipment.

CAUTION



- Handle the instrument carefully so that it is not damaged due to a vibration or shock.
- To avoid damage to the instrument, remove the accessories and optional equipment from the instrument before shipment.

If the instrument is not to be used for an extended period of time

IMPORTANT

To avoid corrosion and/or damage to the instrument due to battery leakage, remove the batteries and store the instrument in a cool, dark place if it will not be used for an extended period of time.

1

Overview

1.1 Overview and Features

The instrument is a multifunctional, high-precision lux meter which ensures durability.

Engineered for use in a wide range of fields and settings, including with lighting equipment, in lighting work, and in equipment management.

Wide-range illuminance measurement (0.00 *lx* to 200000 *lx*)

Use the display unit and sensor unit separately

L9820 Connection Cable (option)



Illuminance sensor

Features a luminosity filter so that the instrument's sensitivity to wavelength approximates the response of the human eye.

Large, easy-to-read LCD

Backlight automatically turns on when you retain the measured value in a low-illuminance environment.

Ability to send data to a computer and to be controlled by a computer

Use the included dedicated computer application (after connecting the instrument with a USB cable) to download data and control the instrument.

Bluetooth communication function (FT3425 only)

The measurement data can be viewed and saved on a smart phone or tablet with the Bluetooth communication function. Uses the GENNECT Cross dedicated smartphone application.

Retaining the measurement (HOLD)

Features the timer hold function.

Memorizes measured values

Internal memory can store up to 99 measured values, which can be sent together to a computer.

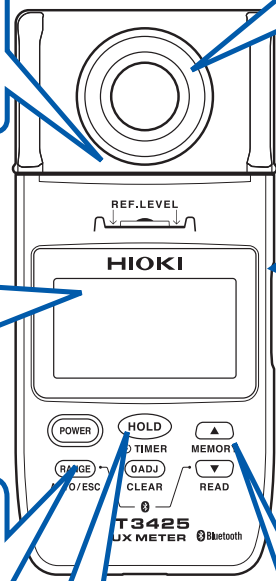

1.2 Parts Names and Functions

Front/Right Side

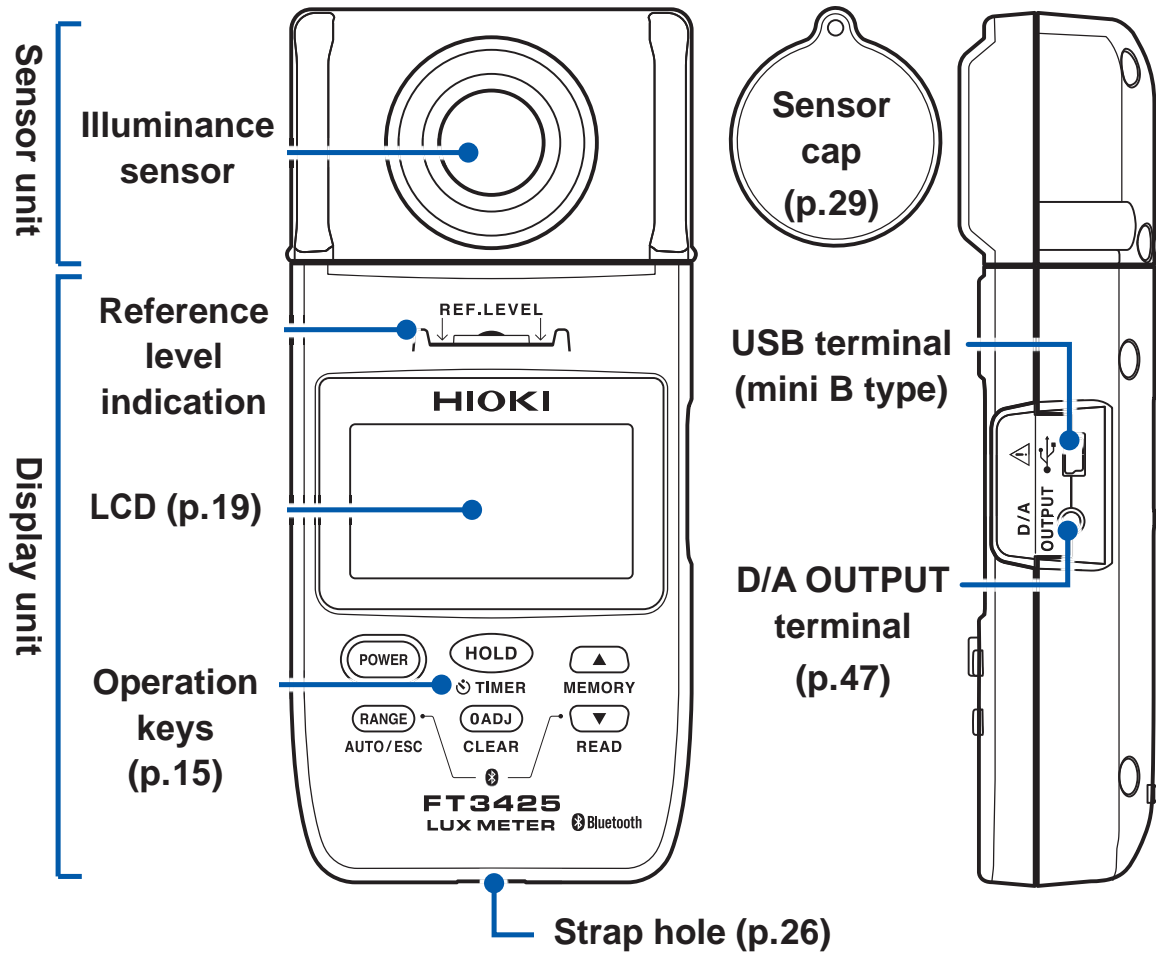

The instrument can be separated into the sensor unit and display unit. (p.37)

(Use the optional L9820 Connection Cable.)

Operation keys



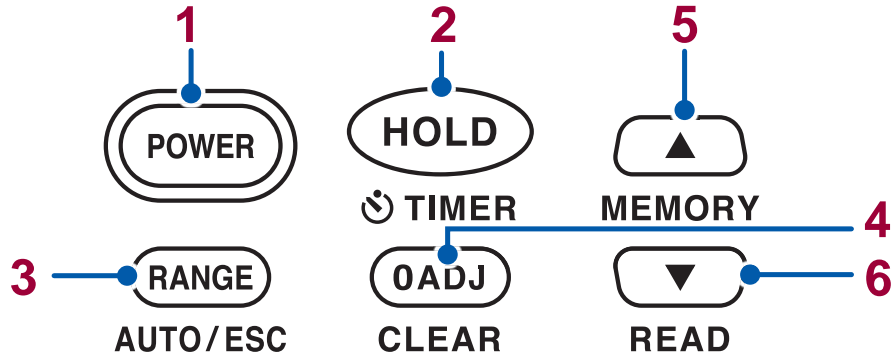

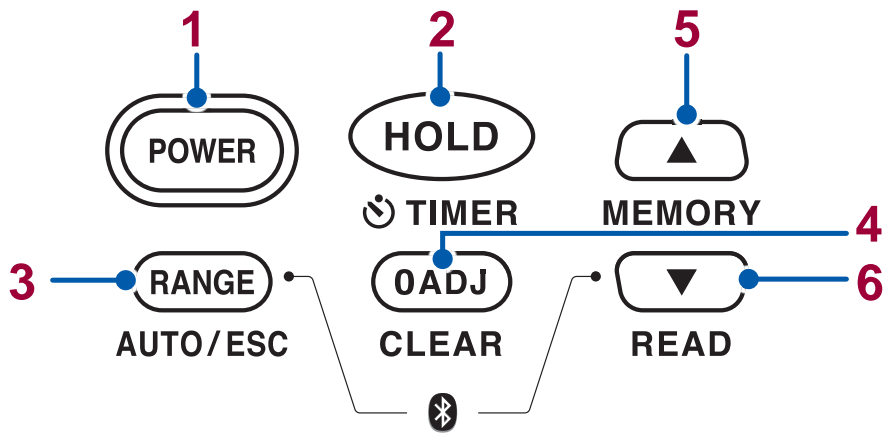

FT3424





FT3425





Parts Names and Functions

		Press	Press and hold for at least 1 second	Turn on the instrument while holding down
1		Turn on the instrument.	Turn off the instrument.	–
2	 	Retains the measured value or cancels retention of the measured value.	Start timer hold function (p.35) Automatically retain after 5 to 60 seconds (designating the time is possible)	Cancels the auto power off function (APS). (p.42)
3	 AUTO/ESC	<ul style="list-style-type: none"> Switches the range. (p.33) Cancels read mode, which allows you to view the measured values stored in the internal memory. *1 (p.45) 	<ul style="list-style-type: none"> Switches to the auto range. When pushed and held together with , starts or disables Bluetooth communications functionality (the setting is stored by the instrument). 	Displays the software version of the instrument.
4	 CLEAR	Performs zero adjustment.	<ul style="list-style-type: none"> Allows you to delete the last saved measured value. *1 (p.46) Cancels zero adjustment when [CAP] is displayed. 	Places the instrument in the state that enables all the measured values stored in the internal memory to be deleted. (p.46)

	Press	Press and hold for at least 1 second	Turn on the instrument while holding down
<p>5  MEMORY</p>	<ul style="list-style-type: none"> • Saves the measured values in internal memory. (p.44) • Increases the memory No.^{*1, *2} • Increases the time remaining on the timer.^{*3} 	<p>Continuously increases the memory No.^{*1} (p.45)</p>	<p>Displays all the indicators on the LCD.</p>
<p>6  READ</p>	<ul style="list-style-type: none"> • Decreases the memory No.^{*1, *2} • Decreases the time remaining on the timer.^{*3} 	<ul style="list-style-type: none"> • Loads the measured values stored in the internal memory for viewing. (p.45) • Continuously decreases the memory No.^{*1} (p.45) • When pushed and held together with , starts or disables Bluetooth communications functionality (the setting is stored by the instrument). 	<p>Sets the buzzer sound non-activated. (p.56)</p>

*1: In the read mode, which allows you to view the measured values stored in the internal memory.

*2:  and  can only be operated when there are multiple measured values stored in the internal memory.

*3: During operation of the timer hold function.



Rear

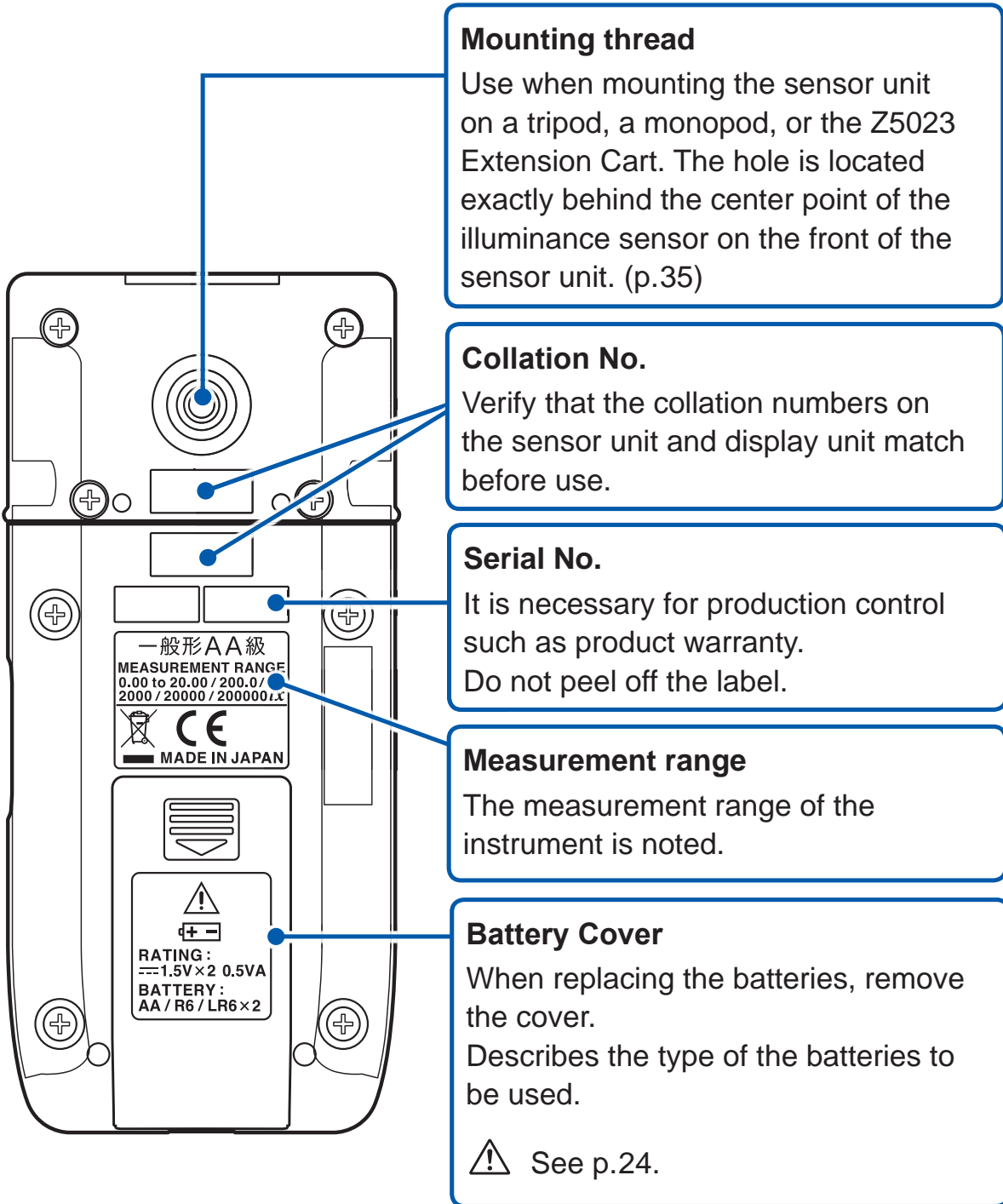

Mounting thread

Use when mounting the sensor unit on a tripod, a monopod, or the Z5023 Extension Cart. The hole is located exactly behind the center point of the illuminance sensor on the front of the sensor unit. (p.35)

Collation No.

Verify that the collation numbers on the sensor unit and display unit match before use.

Serial No.

It is necessary for production control such as product warranty. Do not peel off the label.

Measurement range

The measurement range of the instrument is noted.

Battery Cover

When replacing the batteries, remove the cover. Describes the type of the batteries to be used.

⚠ See p.24.

1.3 LCD

For message displays and error displays, see “5.3 Error Display” (p.70), and “5.4 Display Messages” (p.71).

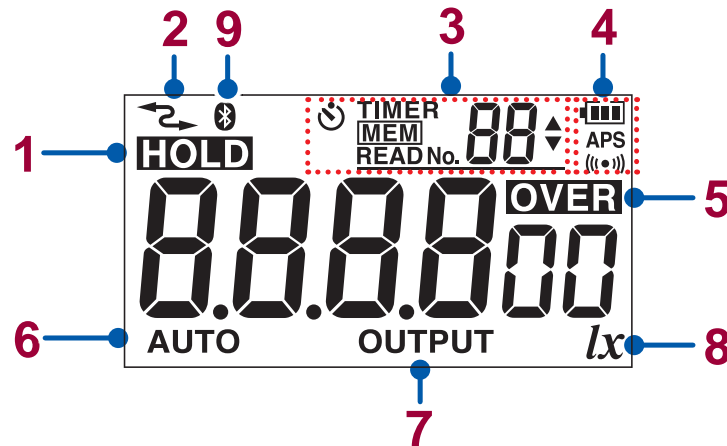

1	HOLD	Holds the measured value. (p.30, p.35)
2		Communicating with the USB. (p.49)
	MEM	The memory function is activated. (p.44)
	MEM READ No. 5	The instrument is in read mode, allows viewing the measured values stored in its internal memory. (p.45), Memory No.
3	TIMER 5	The timer hold function is activated. (p.35) The time shown is the time remaining (in seconds) until the measured value is retained.
		can be operated. (These keys are used to load the measured values and set the timer remaining time.)
		Battery indicator (p.21)
4	APS	The auto power off function is activated. (p.42)
		The buzzer sound is activated. (p.56)
5	OVER	The measured value exceeded the set range's maximum illuminance range.
6	AUTO	The auto range is activated. (p.33)



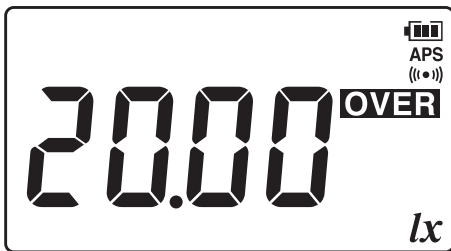

7	OUTPUT	The output function is activated. (p.47)
8	<i>lx</i>	Represents the unit used to measure illuminance (lux).
9		The Bluetooth communication function is activated. (FT3425 only) (p.51)

When the measured value exceeds the maximum value in each range



The maximum displayable value flashes, and **OVER** appears on the LCD.

Battery indicator

	Fully charged.
	As the battery charge diminishes, black charge bars disappear, one by one, from the left of the battery indicator.
	The batteries are almost out of charge. Have a new battery handy.
	<p>(Appears) The batteries are exhausted. Replace with new batteries immediately. (p.24)</p> <p>(Flashes) The batteries are exhausted. Replace with new batteries immediately. If you keep using the instrument, the power may shutdown. (p.24)</p>
OFF	During USB communications and while the instrument is connected to USB bus power, the battery indicator turns off.

The battery indicator is only a reference for the continuous operation time. When using manganese battery or nickel-hydrate batteries, the battery indicator may not operate properly.

Power shutdown



When the charge is gone, **[b. Lo]** flashes on the display for 3 seconds and the power is shut down automatically.

LCD



1.800.561.8187

www.**itm**.com

information@itm.com

2

Measurement Methods

2.1 Measurement Workflow

Before using the instrument, be sure to read “Usage Notes” (p.8).

Installation and connection

Insert the batteries with the sensor cap on. (p.24)

Perform the startup check. (p.28)

As necessary,
have other
optional items
available and
ready.

Measurement

Turn on the power and perform zero adjustment.

(As necessary)

Enable Bluetooth communications functionality and pair with a smartphone. (FT3425 only)

Remove the sensor cap and start the measurement.

(As necessary)

Hold the (display of the) measured value. Save the measurement data in the internal memory. (p.44)

End of the measurement

Turn the power off and put the sensor cap on.

2.2 Inserting/Replacing Batteries

Before using the instrument first time, insert two LR6 alkaline batteries. Before measurements, check that the battery level is sufficient. When the battery charge is low, replace the batteries.

Nickel-metal hydride batteries

Nickel-metal hydride batteries can be used. However, the discharge characteristic of these batteries is different from that of alkaline batteries. Be aware that the remaining battery power display does not function properly.

WARNING



- To prevent the possibility of explosion, do not short-circuit, charge, disassemble, or incinerate batteries.



- To prevent an electric shock, disconnect the output cord and USB cable from the object to be measured before replacing the batteries.
- After battery replacement but before using the instrument, reattach and screw down the battery cover.

CAUTION



Poor performance or damage from battery leakage could result. Observe the cautions listed below.





- Do not mix new and old batteries, or different types of batteries.
- Be careful to observe the battery polarity during installation.
- Do not use batteries after their recommended expiry date.
- Do not allow used batteries to remain in the instrument.

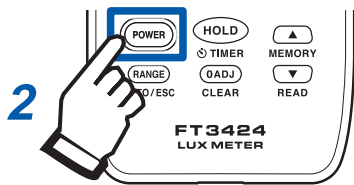

To avoid corrosion from battery leakage and/or damage to the instrument, remove the batteries from the instrument if it is to be kept in storage for an extended period.

- The  indicator appears when the batteries are almost out of charge. Have new batteries handy.
- When the  indicator appears or flashes, there is no battery life remaining. Replace the batteries immediately.
- During USB communications and while the instrument is connected to USB bus power, the battery indicator goes off.
- Turn off the power before replacing the batteries.
- After use, be sure to turn off the instrument.
- Handle and dispose of batteries in accordance with local regulations.



Press and hold  to turn off the instrument.

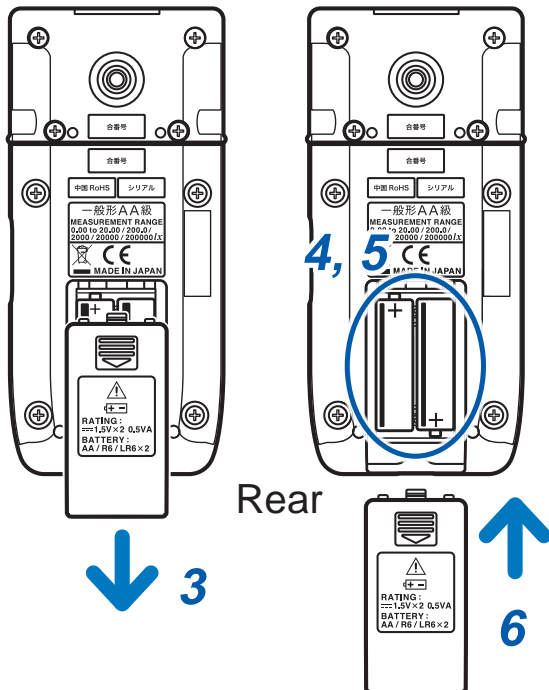

1 Have the following items available and ready.

- LR6 Alkaline battery × 2

2 Turn off the instrument.

3 Remove the battery cover.

4 Remove all of the old batteries.

5 Insert two new batteries (LR6), being careful to the battery polarity.

6 Reattach the battery cover.

Although you can use R6 manganese batteries, doing so will give the instrument a shorter continuous operating time than alkaline batteries.

2.3 Attaching the Strap

You can attach the included strap (for the instrument) and the strap for the sensor cap to the strap hole on the bottom of the display unit.

CAUTION



Attach the strap securely to the instrument. If insecurely attached, the instrument may fall and be damaged when carrying.

When attaching one strap

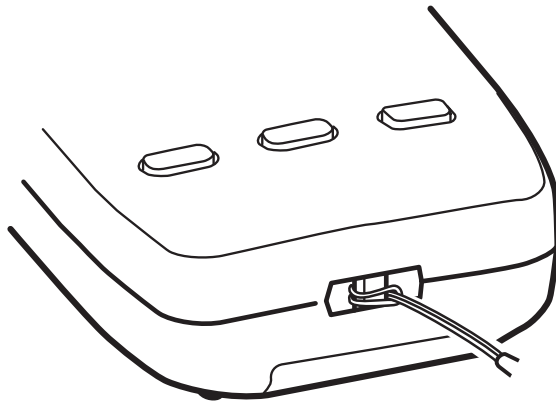

When attaching both straps

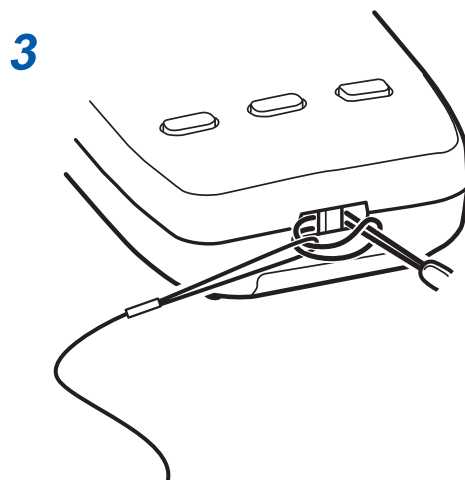
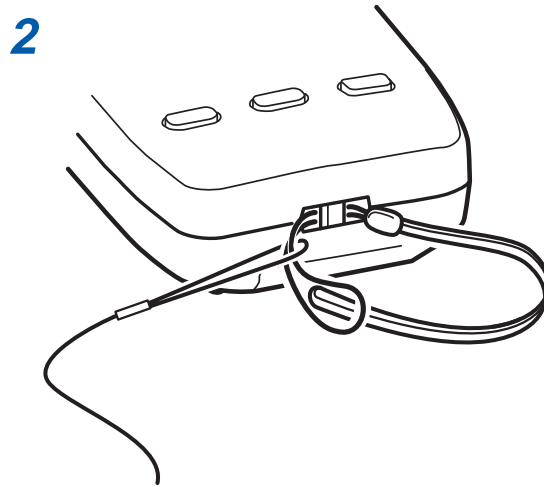
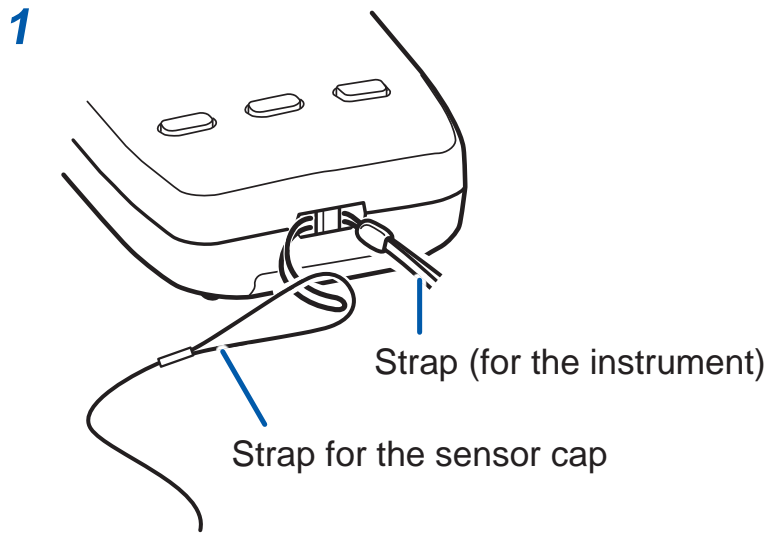

2.4 Inspection Before Use

Verify that the instrument operates normally to ensure that no damage occurred during storage or shipping. If you find any damage, contact your authorized Hioki distributor or reseller.

Appearance check of the instrument

Check item	Action
<ul style="list-style-type: none"> The instrument is neither damaged nor cracked. The internal circuits are not exposed. 	Visually check the instrument. If it is damaged, it could not be measured accurately. Do not use the instrument but send it for repair.

Check when turning on the power

Check item	Action
The battery voltage is sufficient.	When the  indicator appears in the top right corner of the LCD, replace with new batteries immediately. If you keep using the instrument, the power may shutdown. (p.24)
No indicators are missing.	Display all indicators and ensure that no indicators are missing. (p.17, p.19) If any of the indicators are missing, send the instrument for repair.

2.5 Making Measurements

Put the sensor cap on.

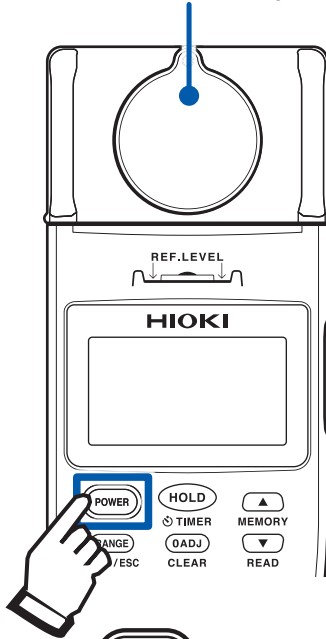

Press **POWER** to turn on the instrument.



- 1 Turn on the instrument with the included sensor cap attached to the illuminance sensor.

A value will be displayed on the LCD.

- 2 Press **OADJ**.

[ADJ] is displayed, and zero adjustment of all ranges will be performed. When zero adjustment is completed, **[ADJ]** goes off.

- 3 Remove the sensor cap, and bring the sensor unit near the measuring location.



(To use a particular range to make a measurement)

4 Press  to select the range.

See: “2.6 Selecting the Measurement Range” (p.33)

5 Read the measured value when it stabilizes.

(When retaining the measured value)

Press  and read the measured value.

Pressing  again will cancel retention of the measured value.

You can also retain the measured value after a set amount of time elapses.

See: “3.1 Retaining the Measured Value after a Set Amount of Time (Timer Hold Function)” (p.35)

Put the sensor cap on.

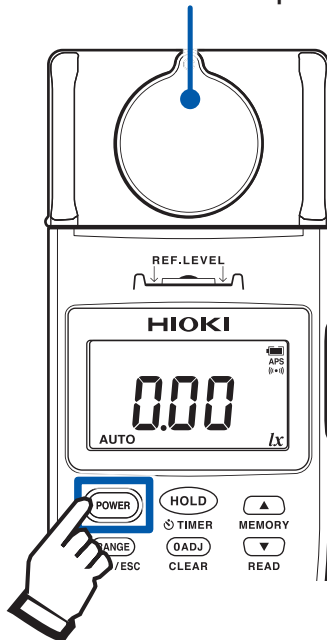

6 When the measurement is finished, put the sensor cap on and turn off the instrument.

Press and hold  to turn off the instrument.

- **OVER** is displayed when the measuring range is exceeded.
- If zero adjustment is performed immediately after the instrument is turned on, several count digits may remain. In that case, perform zero adjustment again.
- While the measured value is retained, zero adjustment cannot be performed.



If **0ADJ** is pressed without the sensor cap attached



If you press **0ADJ** without the included sensor cap attached to the illuminance sensor (when the count is equivalent to 1 lx or greater), **[CAP]** will be displayed on the LCD.

Press **0ADJ** again after attaching the sensor cap.

Zero adjustment will be canceled when pressing and holding **0ADJ** while **[CAP]** is displayed.

2.6 Selecting the Measurement Range

The auto or manual range can be selected.

- Auto range Sets the optimum range automatically in accordance with the actual measurement.
(Disabled when the output function (OUTPUT) is in use.)
- Manual range Fixes the range to a single setting.

Measuring with the auto range



The auto range measurement starts when the instrument power is turned on.

AUTO appears. (default setting)



Measuring with the manual range

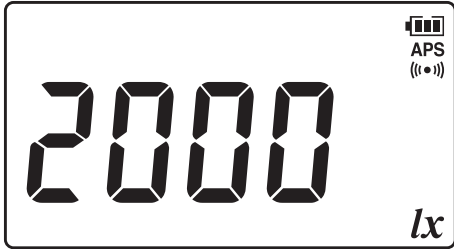

Press **RANGE**.

The instrument will switch from the auto range to manual range, which will be fixed to the range that was selected during auto-range operation. (**AUTO** goes off.)

Each time **RANGE** is pressed, the range is specified.

$$\begin{array}{ccc} 200000 \text{ lx} & \rightarrow & 20.00 \text{ lx} & \rightarrow & 200.0 \text{ lx} \\ & & \uparrow & & \downarrow \\ & & 20000 \text{ lx} & \leftarrow & 2000 \text{ lx} \end{array}$$

To switch to the auto range

Press and hold **RANGE**. (**AUTO** appears.)

While the measured value is retained, the range cannot be switched.

3

Applied Functionality

3.1 Retaining the Measured Value after a Set Amount of Time (Timer Hold Function)

This section describes how to retain the measured value after a set amount of time has elapsed.

The timer hold function is convenient when measuring low illuminance values, for example from emergency lighting or along an evacuation route.

Retaining the measured value (TIMER)

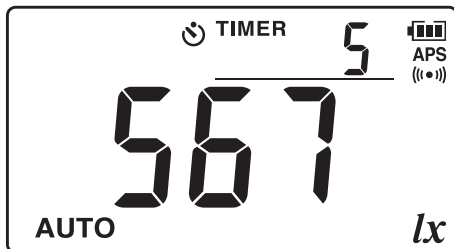

Press and hold **HOLD**.

The timer hold function will be activated, and the time remaining until the measured value is held will be displayed (counted down) at the top right of the LCD. (⌚ **TIMER** appears.)

When the remaining time is 10 seconds or more, the instrument will beep every 5 seconds. When the remaining time is 10 seconds or less, the instrument will beep every second.

You can change the time remaining on the timer by pressing **▲** or **▼** while the timer hold function is active.

(Select from 5, 10, 15, 20, 30, 45, 60 seconds)
Default setting: 5 seconds

Retaining the Measured Value after a Set Amount of Time (Timer Hold Function)

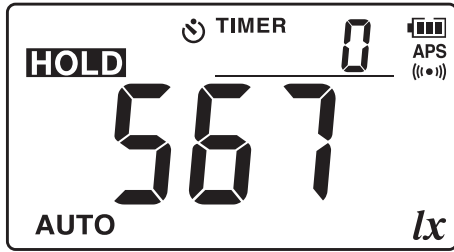



The measured value will be retained once the set amount of time has elapsed.

(**HOLD** and  **TIMER** appear, and a continuous beep sounds for 3 sec.)

When  is pressed again, the hold state is canceled, and the timer hold function is not activated.

(**HOLD** and  **TIMER** go off.)

- Pressing  while the timer hold function is active (while the timer is counting down) will cause the measured value to be retained. At this moment, the timer hold function is not activated. ( **TIMER** goes off.)
- While the measured value is retained, the range cannot be switched.

3.2 Undocking the Display Unit and Sensor Unit

The display unit and sensor unit can be undocked.

- 1 Turn off the instrument.
- 2 Hold the display unit and sensor unit, and pull them gradually apart.

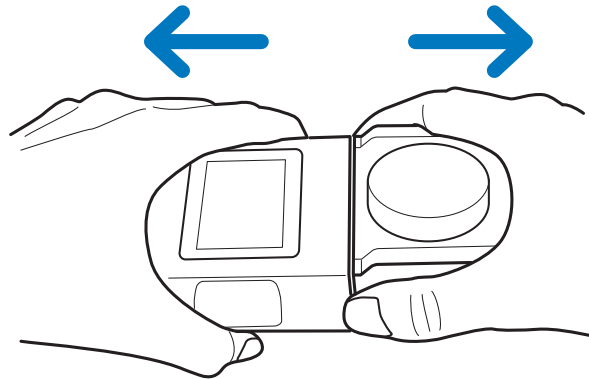

- 3 Connect the display unit and sensor unit with the L9820 Connection Cable (option).

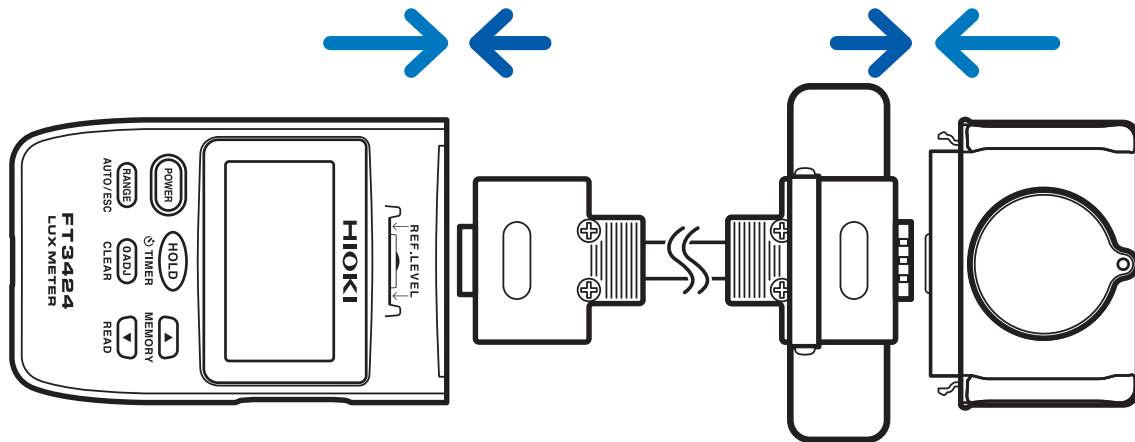

Do not separate and connect the display unit and sensor unit while the instrument power is on.

3.3 Mounting the Sensor Unit on a Tripod or Monopod

Mount the instrument on a commercially available tripod or monopod when making measurements with keeping height from the floor surface. Use the mounting thread* on the back of the sensor unit.

* Thread size: 1/4" (ISO 1222)

Example: When mounted on a tripod

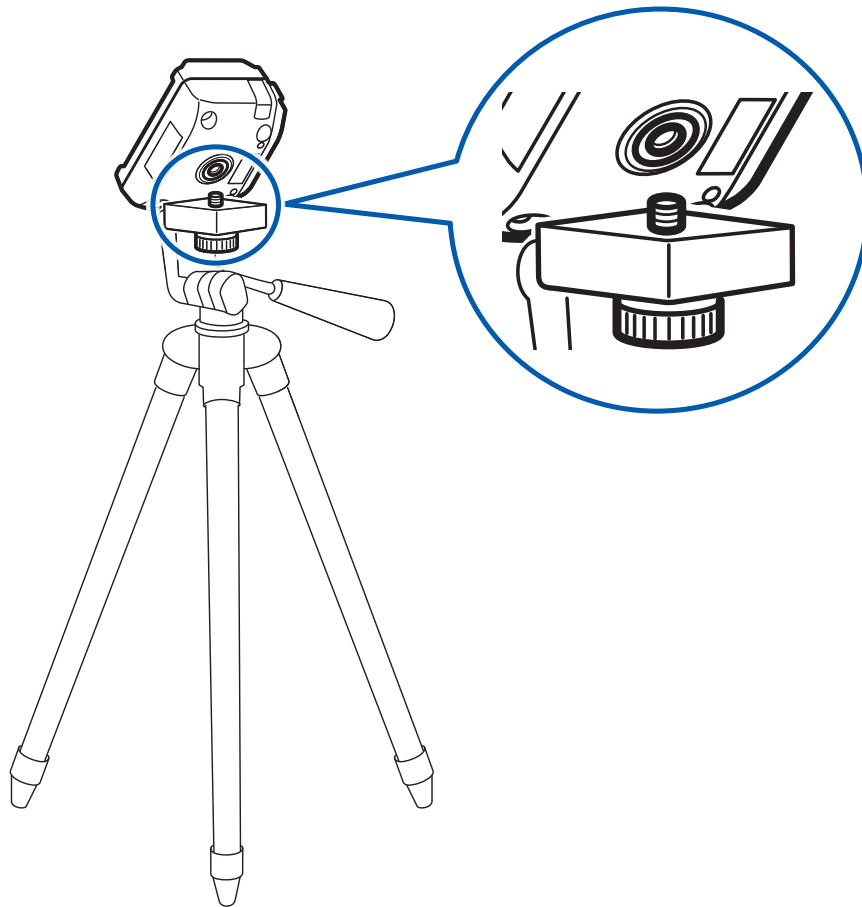

- When mounting the instrument on the tripod or monopod, turn the thread (not the sensor unit).
- Do not lift the tripod or monopod by the instrument after it has been mounted on the tripod or monopod.

3.4 Using the Z5023 Extension Cart

Mount the sensor unit or instrument on the Z5023 Extension Cart to measure illuminance at the floor surface while standing. The cart can be easily moved between measurement locations. In addition, a monopod can be attached to keep height from the floor surface constant.

CAUTION

- The length of the Z5023's handle can be adjusted. Tighten the lock after adjustment and verify that the handle's length has been securely set.
 - Exercise care to ensure that the operator's shadow does not cover the instrument's sensor unit. Measured values will be lower if the unit is obscured by shadow.
 - Remove any dirt or foreign material from the Z5023's wheels before use. Failure to do so may soil or damage the floor.
-
- Do not move the Z5023 over uneven floor surfaces while the instrument is attached to it.
 - When retracting the handle, please be careful not to place your fingers between the handle and the base.

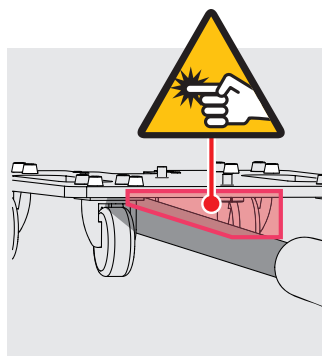
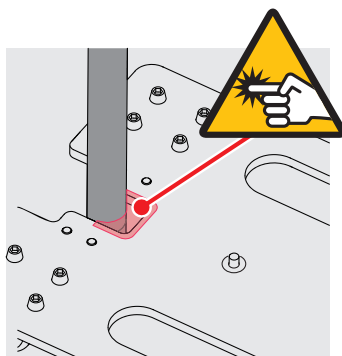

Using the Extension Cart

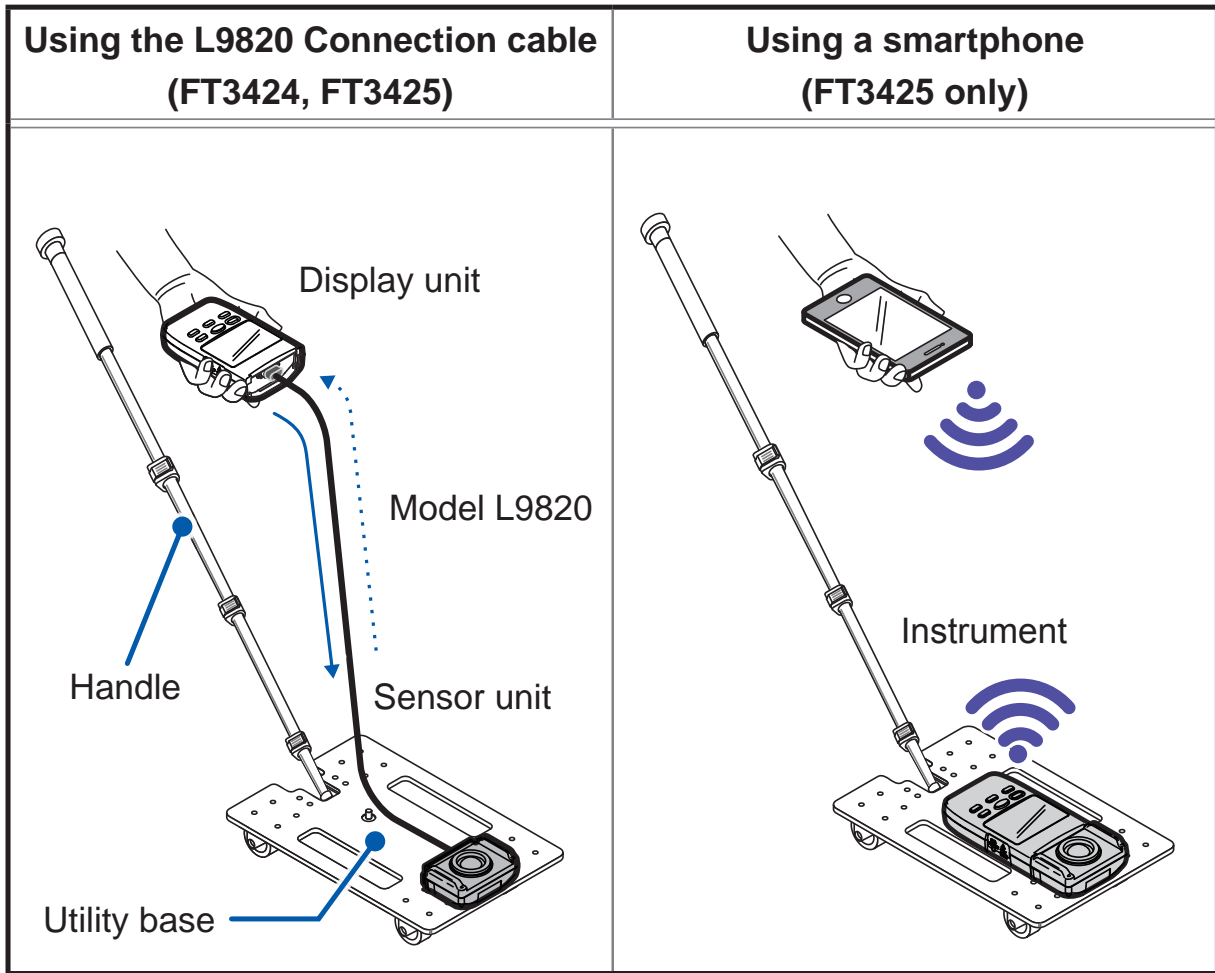

Attaching the instrument

Secure the instrument (using the hole on the back of the sensor unit) to the Z5023 with the included screw*.

* Thread size: 1/4" (ISO 1222)

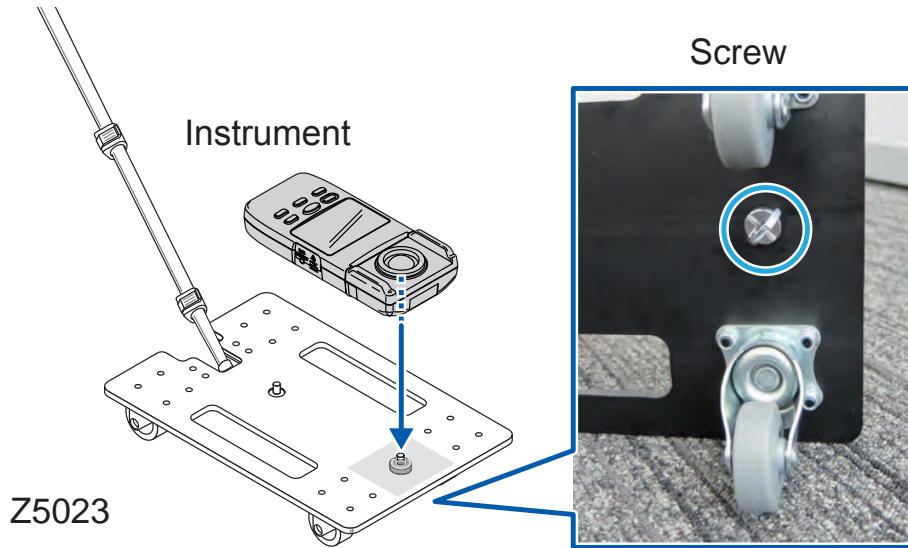

Reference: Attaching a monopod (commercially available)

Secure the instrument (using the hole on the back of the sensor unit) to the monopod, and the monopod to the Z5023 using the included screws*.

* Thread size: 1/4" (ISO 1222)

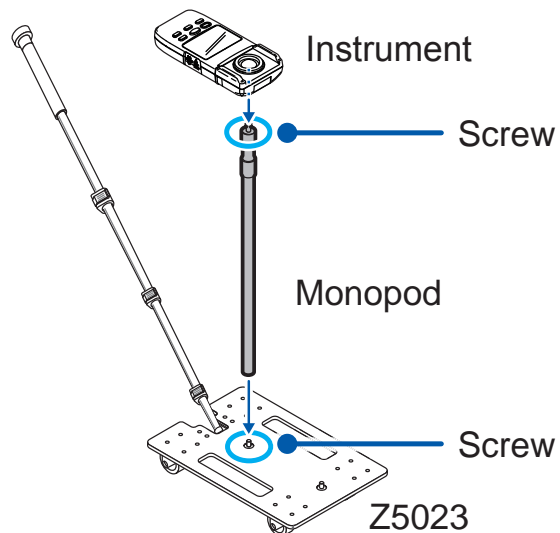

3.5 Limiting Battery Consumption (Auto Power OFF Function)

This function limits the battery consumption. If the instrument has not been operated for approx. 10 minutes, the power turns off automatically. In the original setting (default setting), the auto power off function is set to enabled. (**APS** appears.)

When the auto power off function is enabled, **APS** on the LCD will flash 30 seconds before, along with the beeping sound 15 seconds before the instrument automatically turns off. To continuously use the instrument without turning off the power, press any key on the front panel. When the instrument has not been operated for approx. 10 minutes again since the key was pressed, the power turns off automatically.

- If the instrument will be used continuously for an extended period of time, disable the auto power off function.
- After use, be sure to turn off the instrument.
- When using the output function (OUTPUT), during USB communications, when connected to USB bus power, and during Bluetooth communications, the auto power off function will be disabled.

Disabling the auto power off function

If the instrument is on, turn it off.



Press  while holding down  to turn on the instrument.

The auto power off function is disabled.
Check that **APS** dose not appear on the LCD.

The auto power off function will be disabled until the instrument is turned off. Exercise care concerning battery consumption.



3.6 Saving Measured Values (Memory Function)

The measurement result can be saved and read using the memory function. Up to 99 measured values can be saved.

You can also delete saved measured values. (p.46)

Measured values saved in the internal memory can be downloaded to a computer using the instrument's USB communications capability. (p.49)

The memory function is disabled when the output function (OUTPUT) is in use.

Saving the measured value (MEM)

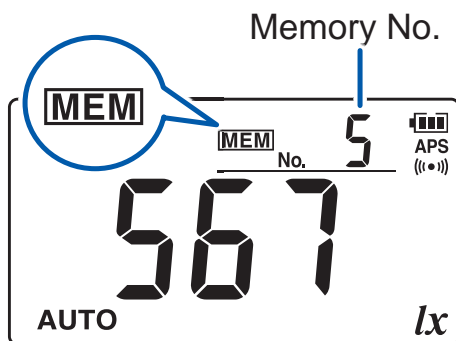

Press  (MEMORY) while measuring.

The measured value when  (MEMORY) is pressed will be saved in the internal memory, starting with the lowest memory No. At this moment, the buzzer sounds, and the memory No. and **MEM** appears for 1 second.

When the internal memory is full

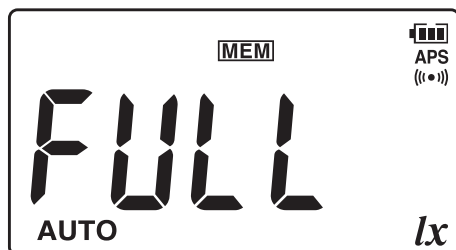

If you try to save a measured value when the internal memory is full (when 99 measured values have been saved), the LCD will show **[FULL]**. To save a new measured value to the internal memory, you must first delete one or more previously saved measured values. (p.46)

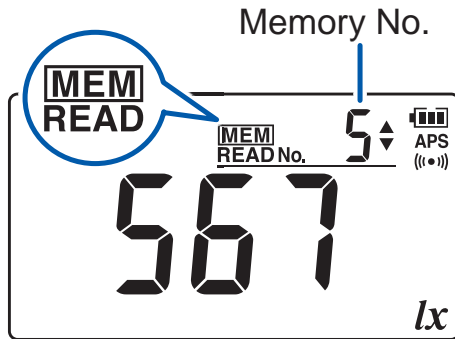

Reading the saved measured values (READ)







1 Press and hold  (READ).

(MEM and READ appear.)

The instrument enters the read mode, which is used to read the measured values saved in the internal memory.

2 Select the desired memory No. using  or . (upper right side of the LCD)

Continuously increase or decrease the memory No. by pressing and holding  or .

 and  can only be operated when there are multiple measured values stored in the internal memory.

The backlight automatically turns on when you read the measured data of the internal memory in low-light environments (approx. 750 lx or less).

Canceling the read mode

Press  (ESC). (READ goes off.)

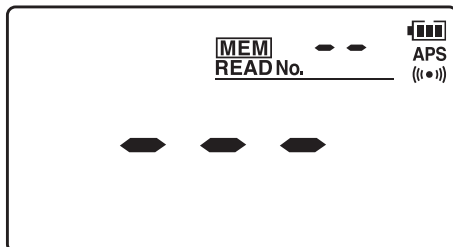

When the measured values are not saved

When the measured values are not saved in the internal memory, press  (READ) and [---] appears on the LCD for approx. 1 second, and then the measurement display reappears.

Deleting the most recently saved measured value (CLEAR)

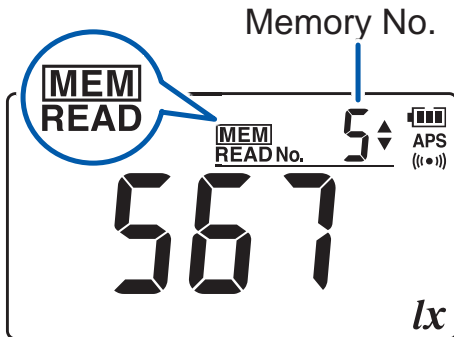

1 Press and hold  (READ).

(MEM and READ appear.)

The instrument enters the read mode, which is used to read the measured values saved in the internal memory.

2 Press and hold  (CLEAR).

The most recently saved measured value (with the last memory No.) is deleted.

You cannot delete the measured value for a specific memory No. other than the last one.

Deleting all the saved measured values

If the instrument is on, turn it off.



1 Press  while holding down  to turn on the instrument.

2 Press and hold  while [CLr] is displayed.

All the saved measured values are deleted. After [CLr] flashes, the measurement display appears.

3.7 Logging Illuminance Data (Output Function)

You can connect the instrument to a logger or other recording instrument and have it generate voltage output based on the measured values.

This functionality outputs a voltage of 1 mV DC for each effective count digit in the measured value. The voltage is updated at the same rate as the instrument's LCD.

CAUTION



To avoid damaging the output cord, unplug it by grasping the connector, not the cord.

- When using the output function (OUTPUT), the following functions are disabled.
 - Auto power off function
 - Memory function
 - Auto range
- When using the output function for an extended period of time, connect a USB cable to the instrument so that it operates on USB bus power.
- If the output cord is plugged in when the instrument is turn on, a signal of +2.5 V will be output temporarily; however this is not a malfunction.

Logging Illuminance Data (Output Function)

- 1 Press and hold **POWER** to turn off the instrument.
- 2 Connect the mini jack of the output cord (option) to the **D/A OUTPUT** terminal of the right side of the instrument.
- 3 (Set the recording instrument in advance.)
Connect the other terminal of the output cord to the logger or other recording instrument.
- 4 Press **POWER** to turn on the instrument.

Connection example

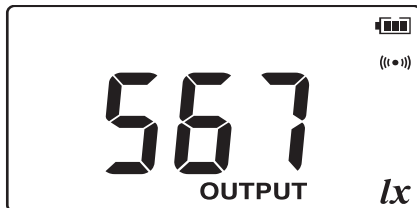
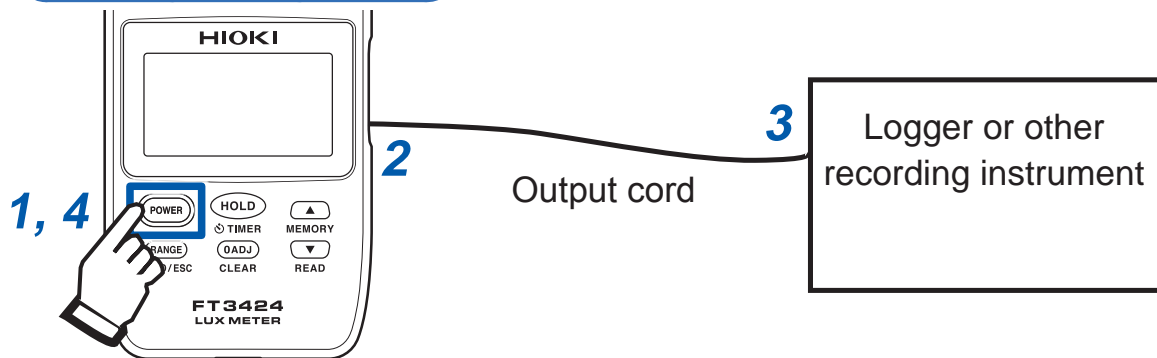

The voltage is output from the D/A OUTPUT terminal, depending on the measured value. (**OUTPUT** appears.)

- 5 Perform zero adjustment as necessary, and select the output rate by pressing **RANGE**. (See the table below)

Range	Output rate
20 lx	1 mV DC / 0.01 lx
200 lx	1 mV DC / 0.1 lx
2000 lx	1 mV DC / 1 lx
20000 lx	1 mV DC / 10 lx
200000 lx	1 mV DC / 100 lx

When the measured value exceeds the full scale in each range, the output is 2.5 V DC. (**OVER** appears on the LCD.)

3.8 Communicating with the PC

Using the included USB cable, it is possible to transmit data to the PC or to control the instrument.

For details, see the communications specifications which accompany with the CD.

Install the dedicated PC application software on the PC.

Verify that Bluetooth communications functionality has been disabled.

Connect the instrument to the PC.

The virtual COM ports of the PC can be used as the USB interface.

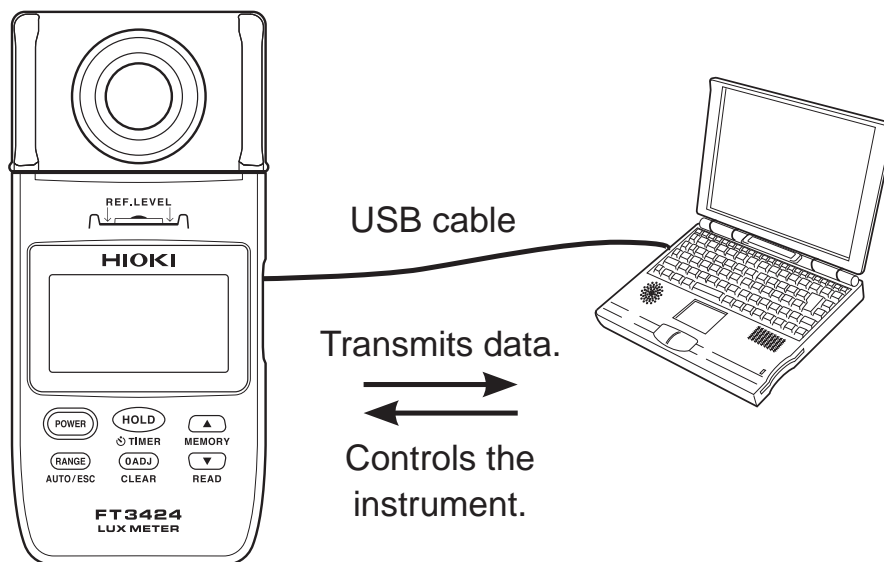

- Verify that Bluetooth communications functionality has been disabled before connecting the USB cable. Connecting the USB cable while Bluetooth communications functionality remains enabled will prevent USB communications.
- Bluetooth communications functionality cannot be enabled or disabled while the USB cable is connected.
- When connecting a USB cable to the instrument, exercise care to orient the connector properly.
- During USB communication, ↔ appears on the LCD.
- During USB communication, do not disconnect the USB cable. Disconnecting the cable stops the communication. In that case, a warning is displayed by the special PC application software. Connect the USB cable again.

3.9 Communicating with a Smart Phone or Tablet (FT3425 only)

The FT3425 supports the **Bluetooth®** low energy. When the Bluetooth function is enabled, you can review and record measurement data and create measurement reports on mobile devices (iPhone, iPad, iPad Mini, iPad Pro, iPod Touch, and Android™ devices). For more information about this functionality, see the help function in the application software GENNECT Cross.

- 1 Install the **GENNECT Cross** on your mobile device. (p.53)





- 2 Press and hold  and  at the same time, enable the Bluetooth function on the FT3425.

- 3 Launch **GENNECT Cross** and pair it with the FT3425. (p.54)

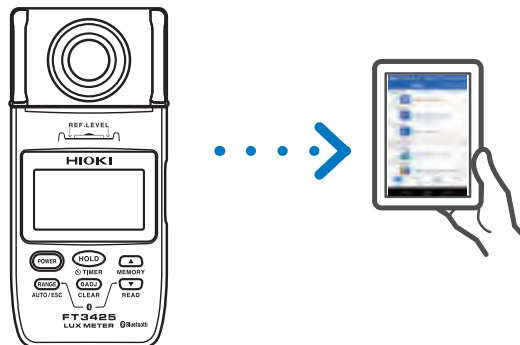
- 4 Select the **[General Measurement]** or **[Illuminance Measurement]**. (p.55)



Communicating with a Smart Phone or Tablet (FT3425 only)

- The Bluetooth communications functionality setting (enabled or disabled) is retained by the instrument, even if it is turned off.
-  appears when the Bluetooth function is activated.
-  flashes when the instrument is connected to a mobile device.
- If the instrument is connected to a PC by USB with Bluetooth communications functionality enabled, Bluetooth communications will take precedence over USB communications. (The instrument will operate on USB bus power rather than the battery.)

Installing the smartphone application

Search for “GENNECT Cross” on the App Store from your iPhone, iPad or other Apple device*, or on Google Play™ from your Android™ device. Then download and install the GENNECT Cross. You will need an Apple ID to download the application from the App Store, or a Google account to download the application from Google Play. For more information about how to register an account, contact the store at which you purchased your device.



- Because the FT3425 emits radio waves, use in a country or region where they have not been approved may be subject to fines or other penalties as a violation of applicable laws or regulations. For more information, see the attached “Precautions Concerning Use of Equipment That Emits Radio Waves” or go to our website.
- The FT3425 availability is limited to certain countries. For more information, contact your authorized Hioki distributor or reseller.
- Bluetooth communications range varies greatly with distance from obstructions (walls, metal obstruction, etc.) as well as distance from the floor or ground. To ensure stable measurement, verify adequate signal strength.
- Although this application is provided free of charge, downloading or use of the application may incur Internet connection charges. Such charges are the sole responsibility of the user.
- This application is not guaranteed to operate on all mobile devices.

Pairing the application with the lux meter (FT3425)

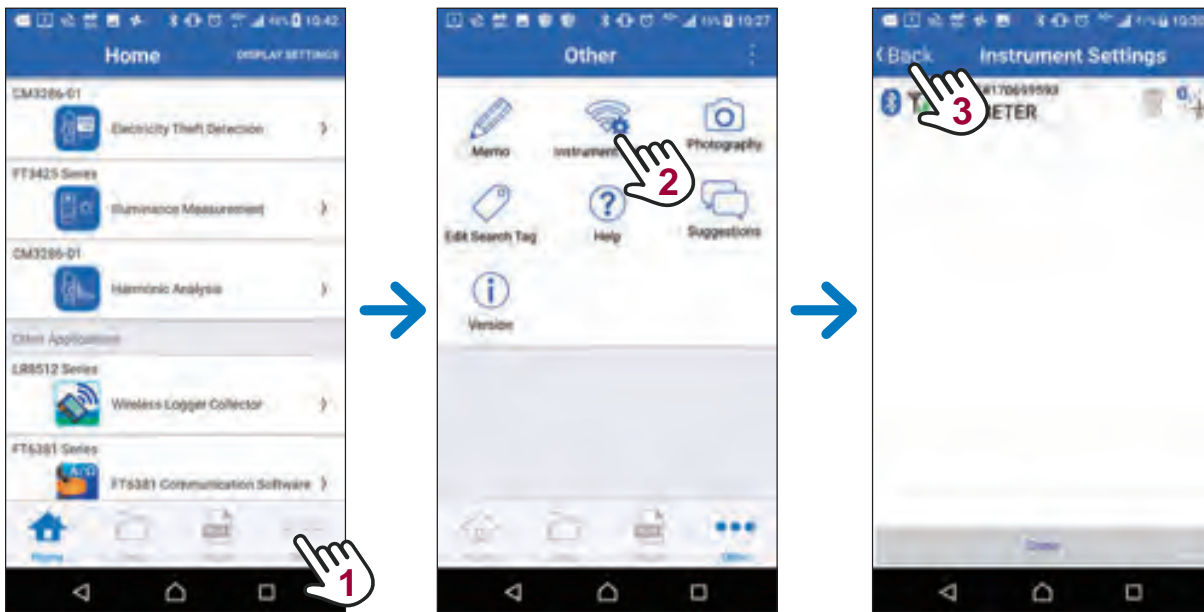

- When the application is launched for the first time (before being paired with any instrument), the connection setup screen will be displayed.
- While the mobile device is displaying the connection setup screen, simply move it close to the FT3425 to automatically pair it with the instrument (the application can be paired with up to 8 instruments).
- Model FT3425 can communicate with a mobile device on a one-on-one basis. No mobile device can be paired with the FT3425 that is talking to another device. Disconnect the device to which the FT3425 is talking.
- Allow about 5 to 30 seconds for the instrument to pair with the application after being turned on. If the instrument fails to pair within 1 minute, relaunch GENNECT Cross and cycle the instrument's power.

Making measurements with the Bluetooth function

Select either **[General Measurement]** or **[Illuminance Measurement]** on the home screen and measure. For more information about each function, see the help function in the GENNECT Cross.

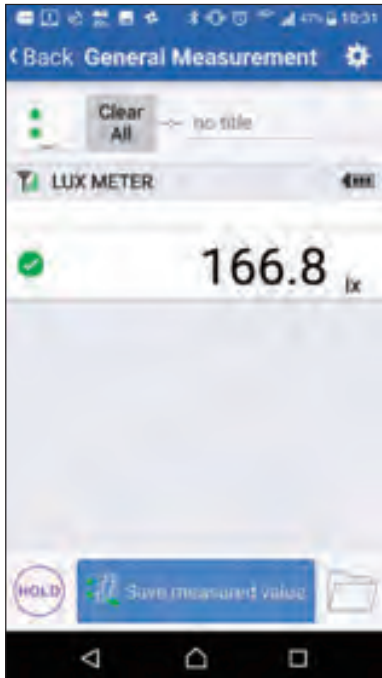

General measurement function

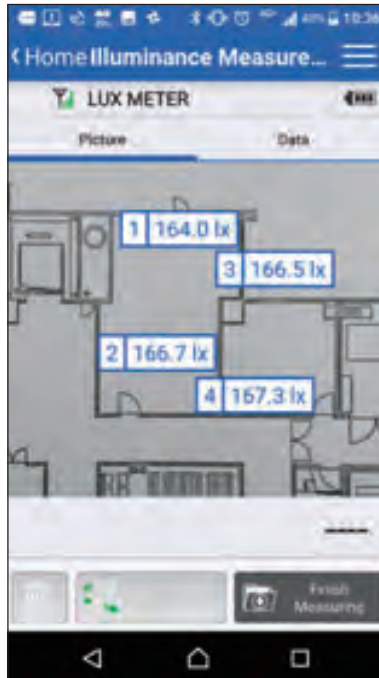

Illuminance measurement function (Measurement location display function)

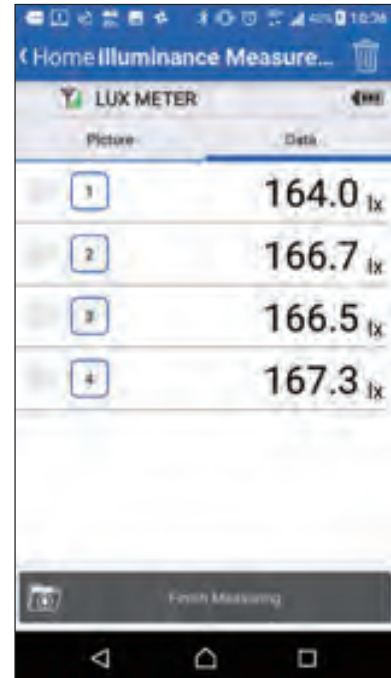



Illuminance measurement function (List display screen)

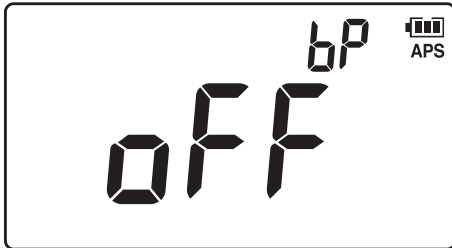

3.10 Disabling the Buzzer

The buzzer sound is enabled when factory default settings. Turn off the power of the instrument when changing the settings.



Press  while holding down  to turn on the instrument.

[bP OFF] is displayed, and the buzzer is not activated.

When you release , the screen will return to the measured value display. ( goes off.)

The buzzer sound is disabled until the power is turned off.

3.11 Turning On the Backlight

The LCD includes a backlight for use when making measurements in dim locations. The backlight will activate automatically when the measured value is retained or when the measured value data stored in the internal memory is in read mode, both in low-light environments (approx. 750 *lx* or less).

To avoid affecting measurement results, the backlight cannot be turned on during measurement.

Forcing the backlight to turn on

To forcibly turn on the backlight in an environment with illuminance that is greater than or equal to approximately 750 *lx*, attach the sensor cap to the illuminance sensor while retaining the measured value.

Activation and deactivation of the backlight is unrelated to the measured value that is being retained. The illuminance sensor continuously monitors illuminance, and the instrument determines whether to turn the backlight on or off based on a monitored illuminance level of approximately 750 *lx*.

Turning On the Backlight

4

Specifications

4.1 Basic Specifications

Classifications Grade JIS C 1609-1: 2006 General Class AA

Display

- Display LCD 4 digits
- Effective display digits 2000 counts
- Display unit *lx* (lux)
- Display update rate 500 ms ± 20 ms

Measurement ranges

Range	Measuring range	Display steps
20 <i>lx</i>	0.00 <i>lx</i> to 20.00 <i>lx</i>	in increments of 1 count
200 <i>lx</i>	0.0 <i>lx</i> to 200.0 <i>lx</i>	
2000 <i>lx</i>	0 <i>lx</i> to 2000 <i>lx</i>	
20000 <i>lx</i>	00 <i>lx</i> to 20000 <i>lx</i>	in increments of 10 counts
200000 <i>lx</i>	000 <i>lx</i> to 200000 <i>lx</i>	in increments of 100 counts

Measurement range selection Auto / Manual



4.2 Measurement Specifications

Accuracy

Linearity	±2% rdg. (Multiply by 1.5 for display values in excess of 3000 <i>lx</i> .) (Add ±1 dgt. for display values that are less than 1/3 of the range.)
Accuracy guarantee conditions	The display unit and sensor unit must bear the same collation No.
Accuracy guarantee for temperature and humidity	21°C to 27°C (69.8°F to 80.6°F), 75% RH or less (no condensation)
Accuracy warranty period	2 years
Accuracy warranty period after adjustment	2 years

- f.s. (maximum display value): The maximum displayable value. This is usually the name of the currently selected range.
- rdg. (reading value): The value currently being measured and displayed on the measuring instrument.
- dgt. (resolution): The minimum display unit, indicating a minimum digit of 1.

Characteristics

Angled incident light characteristics	Systematic deviation f_2 : 3% or less Deviation from cosine characteristics:								
	<table border="1"> <thead> <tr> <th data-bbox="544 457 755 520">Angle</th> <th data-bbox="755 457 1404 520">Deviation from cosine characteristics</th> </tr> </thead> <tbody> <tr> <td data-bbox="544 520 755 583">30°</td> <td data-bbox="755 520 1404 583">±2%</td> </tr> <tr> <td data-bbox="544 583 755 646">60°</td> <td data-bbox="755 583 1404 646">±7%</td> </tr> <tr> <td data-bbox="544 646 755 709">80°</td> <td data-bbox="755 646 1404 709">±25%</td> </tr> </tbody> </table>	Angle	Deviation from cosine characteristics	30°	±2%	60°	±7%	80°	±25%
Angle	Deviation from cosine characteristics								
30°	±2%								
60°	±7%								
80°	±25%								
Response time	Auto range: 5 seconds or less Manual range: 2 seconds or less								
Temperature characteristics	Deviation from the value measured at 23°C (73.4°F) between -10°C to 40°C (14°F to 104°F): ±3% rdg.								
Humidity characteristics	Deviation from value measured in an environment with a temperature and humidity of 23°C (73.4°F), and 45% RH to 70% RH when the instrument is left in an 85% RH to 95% RH environment for 3 hours and then is returned to the original environment: ±3% rdg.								
Relative spectral response characteristics in the visible spectrum	Deviation from spectral luminous efficiency (relative luminous efficiency) f_1' : 6% or less								
Response characteristics in ultraviolet and infrared spectrums	Response to ultraviolet and infrared radiation : 1% or less								
Fatigue characteristics	The change in the value of 1 minute and 10 minutes after light strikes the sensor : ±1% rdg.								
Characteristics regarding intermittent light	Deviation in value when subjected to intermittent light for 1/2 cycle at a frequency of 100 Hz or 120 Hz : ±2% rdg.								



4.3 Output Specifications

Output method	D/A output
Output level	2 V/ range f.s. 2.5 V is output when the range f.s. is exceeded.
Resolution	1 mV

Range	Output rate
20 <i>lx</i>	1 mV DC / 0.01 <i>lx</i>
200 <i>lx</i>	1 mV DC / 0.1 <i>lx</i>
2000 <i>lx</i>	1 mV DC / 1 <i>lx</i>
20000 <i>lx</i>	1 mV DC / 10 <i>lx</i>
200000 <i>lx</i>	1 mV DC / 100 <i>lx</i>

Output update rate	500 ms \pm 20 ms
Output accuracy	\pm 1% rdg. \pm 5 mV (at display count)
Output resistance	1.1 k Ω or less

4.4 Functional Specifications

Hold function	Retains the measured value.
Timer hold function	Retains the measured value after the set timer time has elapsed after executing. Select and set the timer time from 5, 10, 15, 20, 30, 45, 60 seconds.
Memory function	Up to 99 measured data can be saved.
Auto power off function	Turns off the instrument approx. 10 minutes after the last key operation (can be canceled).
Power shutdown	When the charge is gone, [b. Lo] flashes in the display for 3 seconds and the power is shut down.
Buzzer sound	Emits a buzzer sound when keys are operated, when the timer hold function activates, and when the auto power off function is activated. (The buzzer sound can be canceled).
Backlight	Activates when the measured value is retained or when the measured value data stored in the internal memory is in read mode, both while the ambient illuminance is less than 750 <i>lx</i> .
Zero adjustment	Performs zero adjustment. Zero adjustment execution time: 3 seconds or less



4.5 General Specifications





Product warranty period	3 years
Light receiving element	Silicon photo diode
Interface	USB 2.0 (FT3424, FT3425), Bluetooth 4.0LE (FT3425 only)
Operating temperature and humidity	-10°C to 40°C (14°F to 104°F), 80% RH or less (no condensation)
Storage temperature and humidity	-20°C to 50°C (-4°F to 122°F), 80% RH or less (no condensation)
Operating environment	Indoors, pollution degree 2, altitude up to 2000 m (6562 ft.)
Power supply	LR6 Alkaline battery × 2 R6 Manganese battery × 2 Rated power voltage 1.5 V DC × 2 (Maximum allowable voltage 3.6 V DC) USB bus power 5 V DC
Continuous operating time	FT3424: Approx. 300 hours FT3425: Approx. 300 hours (Without Bluetooth communications) Approx. 80 hours (With Bluetooth communications) (when LR6 alkaline batteries are used)
Maximum rated power	500 mVA
Dimensions	Approx. 78W × 170H × 39D mm (3.07" W × 6.69" H × 1.54" D)

Mass	FT3424: Approx. 310 g (10.9 oz.) FT3425: Approx. 320 g (11.3 oz.) (including the batteries)
Standard compliance	<ul style="list-style-type: none"> • JIS C 1609-1: 2006 General Class AA • DIN 5032-7: 1985 Class B
Applicable standards (other than wireless)	<ul style="list-style-type: none"> • Safety: EN61010 • EMC: EN61326
Dustproof and waterproof	<p>IP40 (EN60529)</p> <div style="border: 2px solid #00AEEF; border-radius: 10px; padding: 10px; background-color: #E6F2FF;"> <p>To avoid any failure, do not allow the instrument to get wet. If the instrument gets wet, have your authorized Hioki distributor or reseller inspect or repair it, if necessary.</p> </div>
Accessories	<ul style="list-style-type: none"> • Instruction manual • Precautions concerning use of equipment that emits radio waves (FT3425 only) • LR6 Alkaline battery × 2 • Sensor cap (with the strap) • Carrying case (soft) • Strap (for the instrument) • USB cable (0.9 m) • CD (USB driver, dedicated computer application software, and communications specifications)
Options	See: “Options (Sold Separately)” (p.3)



4.6 Bluetooth Communication Specifications (FT3425 only)

Display of measured values on a smartphone or tablet

Instrument operation	Bluetooth communications function disabled:  goes off Bluetooth communications function enabled:  appears Bluetooth communications active:  flashes (The enabled/disabled setting is stored in the instrument's memory.)
Interface	Bluetooth 4.0LE ( Bluetooth®)
Antenna power	Maximum +0 dBm (1 mW)
Communication distance	Approx. 10 m (line of sight)
Communication profile	GATT (Generic Attribute Profile)
Supported OS	Supported iOS devices: iOS 10 or later (Bluetooth low energy enabled devices) Supported Android devices: Android 4.3 or later (Bluetooth low energy enabled devices)
Supported instrument	Model FT3425

5

Maintenance and Service

5.1 Repair, Inspection, and Cleaning

Calibrations

IMPORTANT

Periodic calibration is necessary in order to ensure that the instrument provides correct measurement results of the specified accuracy.

The calibration interval for the instrument is 2 years. It is recommended to calibrate it every 2 years for accurate measurement.

Backing up the data

The instrument may be initialized (returned to the factory default settings) when it is repaired or calibrated.

Before you ask for repair or calibration, it is recommended to back up (save or record) the measurement conditions and measured data.

Cleaning

- To clean the instrument, wipe it gently with a soft cloth moistened with water or mild detergent.
- Wipe the illuminance sensor and the LCD gently with a soft, dry cloth.

IMPORTANT

Never use solvents such as benzene, alcohol, acetone, ether, ketones, thinners or gasoline, as they can deform and discolor the case.

Disposal

Handle and dispose of the instrument in accordance with local regulations.

5.2 Troubleshooting

- When a malfunction of the instrument is suspected, check the information in “Before sending the instrument for repair” and then, if necessary, contact your authorized Hioki distributor or reseller.
- When sending the instrument for repair, remove the batteries and pack it carefully to prevent damage during transportation. Include cushioning material so the instrument cannot move within the package. Be sure to include details of the problem. Hioki cannot be responsible for damage that occurs during transportation.

Before sending the instrument for repair

Symptom	Check and/or remedy
Nothing appears on the display. Or the display disappears after a short time.	Check that the batteries are not exhausted. (p.21) Replace with new batteries. (p.24) When using manganese batteries or nickel-hydride batteries, the battery indicator may not operate properly.
	When the auto power off function is enabled and the instrument has not been operated for approx. 10 minutes, the power turns off automatically. Check the setting of the auto power off function. (p.42)
The display does not stabilize and the value fluctuates; it is difficult to read the value.	When measuring illuminance underneath a standard lighting fixture, the display may not stabilize. In most cases, a failure to stabilize is due to fluctuations in the lighting fixture’s supply voltage or to the surrounding environment (for example, a person’s shadow). Exercise care concerning these factors when performing measurement.
The range cannot be changed.	While the measured value is retained, the range can not be changed. Please cancel the hold function.

Symptom	Check and/or remedy
<p>Turning on the power brings up the error display.</p> <p>When nothing is connected, the error display appears.</p>	<p>Send the instrument for repair.</p> <p>Refer to “5.3 Error Display” (p.70)</p>

Frequently asked questions (FAQ)

Question	Solution
<p>Would like to perform zero adjustment.</p>	<p>Perform zero adjustment.</p> <p>Refer to “2.5 Making Measurements” (p.29)</p>
<p>Can rechargeable batteries be used?</p>	<p>Nickel-metal hydride batteries can be used. However, the discharge characteristic of these batteries is different from that of alkaline batteries. Be aware that the remaining battery power display does not function properly.</p>
<p>Would like to control multiple instruments with 1 PC.</p>	<p>It is possible to control multiple instruments by connecting the USB cable.</p>
<p>The instrument cannot communicate with the PC.</p>	<ul style="list-style-type: none"> • Check the communication setting between the instrument and the PC. For details, see the communications specifications on the accompanying CD. • Check that the USB cable is connected correctly. (p.49) • Verify that the illuminance sensor is not dirty.
<p>Would like to know the communication commands.</p> <p>Would like to perform communication using own software.</p>	<p>To communicate with the instrument and PC, install the USB driver and dedicated application software first.</p> <p>For details on the communication commands, see the communications specifications on the accompanying CD.</p>



5.3 Error Display

Error display	Description	Solution
Err 01	ROM error Malfunction of the program	<p>When the error appears on the LCD, it is necessary to repair the instrument.</p> <p>Contact your authorized Hioki distributor or reseller.</p>
Err 02	ROM error Malfunction of the adjustment data	
Err 04	EEPROM error Malfunction of the memory data	
Err 08	Bluetooth error Malfunction of the hardware (FT3425 only)	

5.4 Display Messages

Display	Description	Reference
AdJ	Performing zero adjustment.	p.29
b. Lo	The batteries are exhausted. Replace the batteries.	p.24
off ^{bP}	Disabling the buzzer.	p.56
CAP	Zero adjustment cannot be performed since the sensor cap is not attached. Attach the sensor cap.	p.32
CLr	All the saved measured values will be deleted. Continue?	p.46
Err	An internal ROM or EEPROM error has occurred. Send the instrument for repair.	p.70
FULL	The internal memory is full. Delete the measured values in the internal memory.	p.46
n.c.	The display unit and sensor unit are not connected. Connect the display unit and sensor unit, either directly or with a connection cable.	—
---	No measured values saved in the internal memory.	p.45

Error Display

Appendix

Appx. 1 Recommended Levels of Illumination (Reference)

Suitable levels of illuminance (according to the JIS standard Z 9110).

Offices

Recommended illuminance [lx]	Illuminance level [lx]	Place/work activity
750	500 to 1000	Design rooms, offices, board rooms
500	300 to 750	Computer rooms, conference rooms, reception rooms
300	200 to 500	Reception area, dining rooms, elevator halls
200	150 to 300	Pantries, locker rooms, restrooms

Factories

Recommended illuminance [lx]	Illuminance level [lx]	Place/work activity
1500	1000 to 2000	Extremely precision visual work such as producing precision mechanical equipments and electronic parts
750	500 to 1000	Precision visual work such as analyzing in chemical factories
500	300 to 750	Ordinary visual work in manufacturing plants
150	100 to 200	Stairways, cargo loading, unloading and movement
50	30 to 75	Indoor emergency stairways

Recommended Levels of Illumination (Reference)

Schools

Recommended illuminance [lx]	Illuminance level [lx]	Place/work activity
1000	750 to 1500	Precision handicraft, precision experimenting
750	500 to 1000	Precision drawing or drafting
500	300 to 750	Experiment demonstration rooms, library reading rooms, nurse's office, kitchen
300	200 to 500	Classrooms, gymnasium, office rooms, cafeteria
100	75 to 150	Corridors, connecting corridors, entrance

Appx. 2 Sensor Characteristics Graphs

Relative Spectral Response Characteristics in the Visible Spectrum

Human perception of brightness ranges from 380 nm to 780 nm in the wavelength and is the maximum at 555 nm. The International Commission on Illumination (CIE) has established comparative standards for luminosity, setting the maximum perception for 1 and indicating the amount of perception of each wavelength by the relative value, and calculating the average of many people. In the instrument, the relative spectral response characteristics are close to the comparative standards for luminosity.

The deviation from the comparative standards for luminosity is determined by the f_1' value of JIS standard C 1609-1:2006.

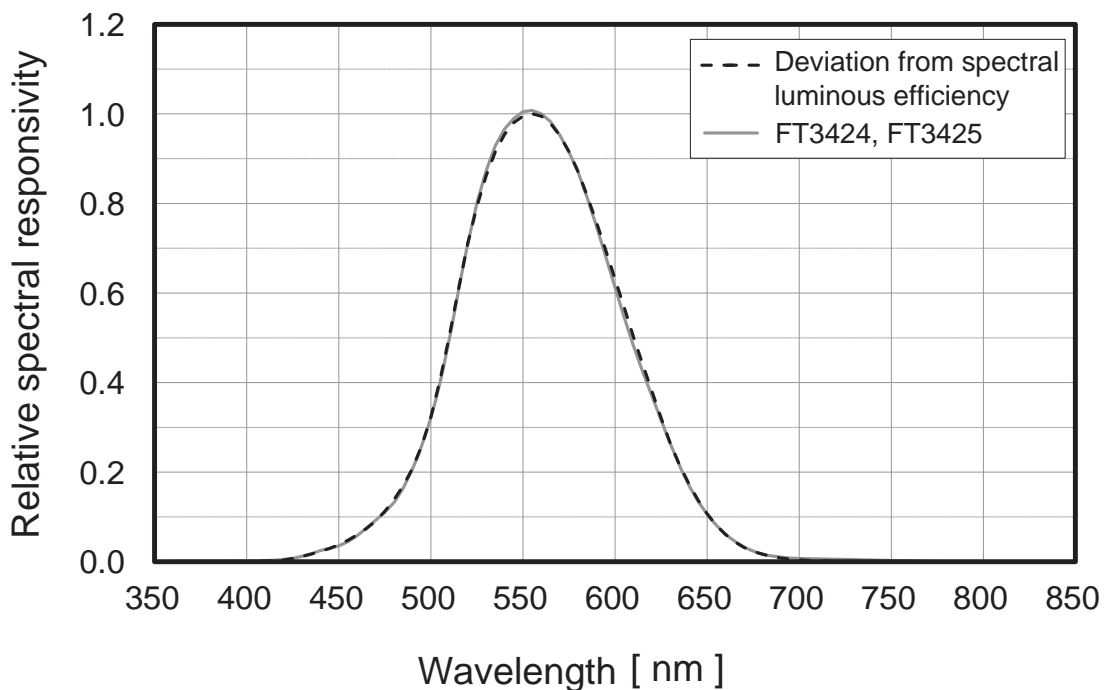

The graph illustrates typical characteristics. Characteristics exhibited by individual products may vary slightly.

Angled Incident Light Characteristics

It is known that the luminance is proportional to the cosine of the incident angle of light (the cosine law).

In the instrument, the shape of the light sensor, hook etc. is so made that it can follow the cosine law closely.

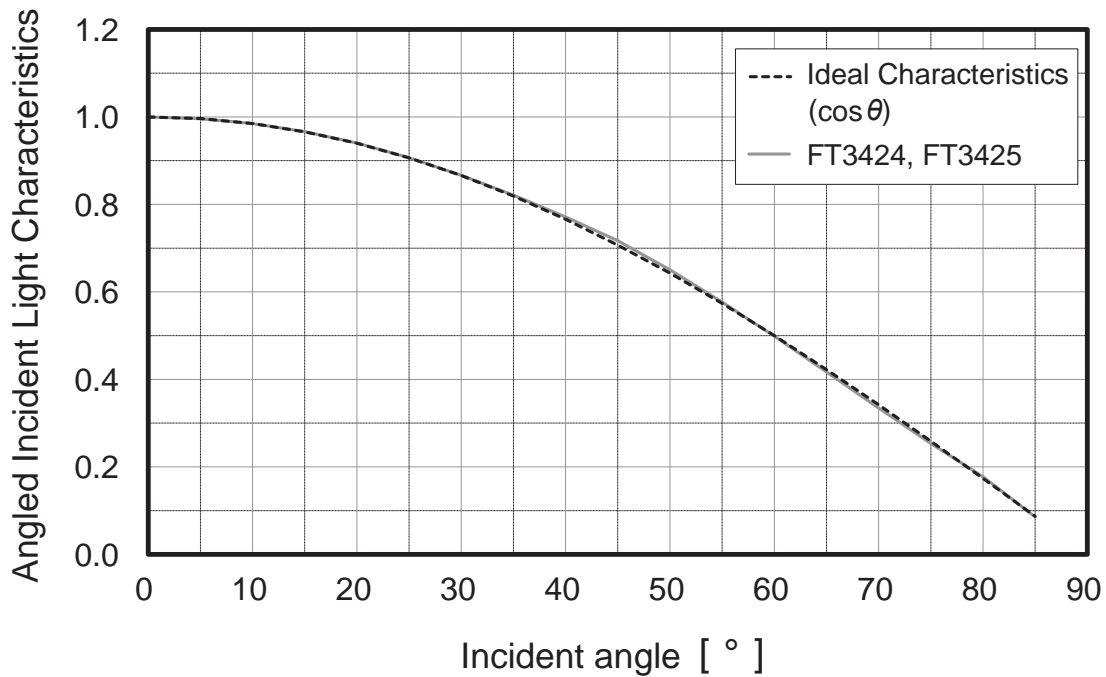

The graph illustrates typical characteristics. Characteristics exhibited by individual products may vary slightly.

Appx. 3 Other Characteristics

Color correction factor for a general light source relative to standard illuminant A

Light source	k
Fluorescent lamp F6	1.003
Fluorescent lamp F8	1.002
Fluorescent lamp F10	1.002
High-pressure sodium lamp	1.011
Metal halide lamp H1	1.002
Metal halide lamp H2	1.003
High-pressure mercury lamp	0.995

The table shows typical characteristics. Characteristics exhibited by individual products may vary slightly.

Range of distances in which the law of inverse squares relative to distance applies

50 cm from the measurement reference level

Incidence uniformity

The instrument is designed to be used under conditions in which the illuminance distribution on the sensor surface is roughly uniform. An error component will be introduced into measurements if the illuminance distribution on the sensor surface is non-uniform, for example when measuring a light source with strong directionality.



Appx. 4 Dimensional Drawings

Unit : mm

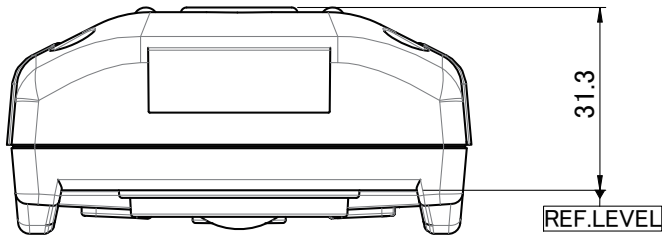

The FT3424 and FT3425 have the same dimensions.

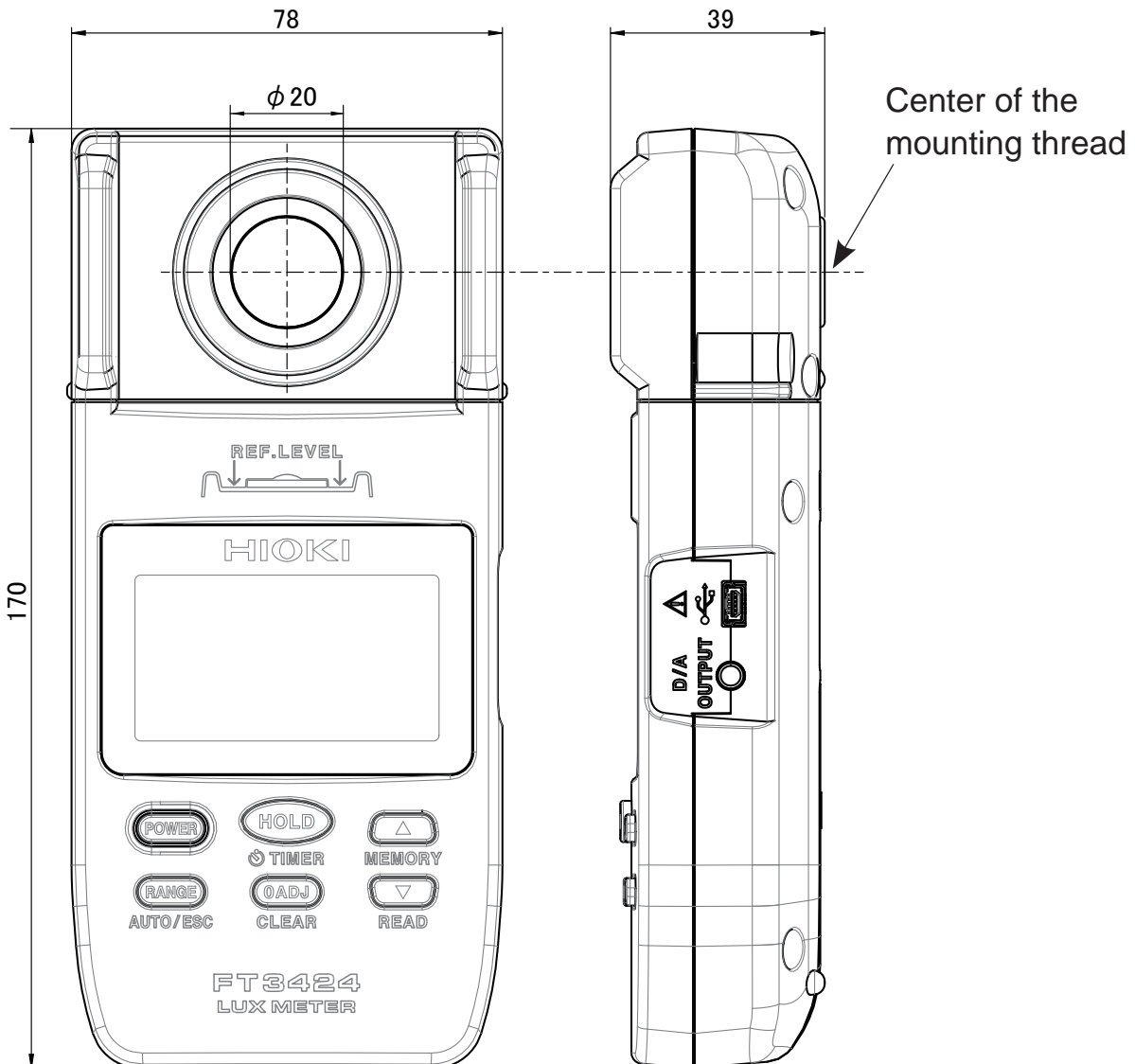

Warranty Certificate

HIOKI

Model	Serial number	Warranty period Three (3) years from date of purchase (___ / ___)
-------	---------------	--

Customer name: _____
Customer address: _____

Important

- Please retain this warranty certificate. Duplicates cannot be reissued.
- Complete the certificate with the model number, serial number, and date of purchase, along with your name and address. The personal information you provide on this form will only be used to provide repair service and information about Hioki products and services.

This document certifies that the product has been inspected and verified to conform to Hioki's standards. Please contact the place of purchase in the event of a malfunction and provide this document, in which case Hioki will repair or replace the product subject to the warranty terms described below.

Warranty terms

1. The product is guaranteed to operate properly during the warranty period (three [3] years from the date of purchase).
If the date of purchase is unknown, the warranty period is defined as three (3) years from the date (month and year) of manufacture (as indicated by the first four digits of the serial number in YYMM format).
2. If the product came with an AC adapter, the adapter is warranted for one (1) year from the date of purchase.
3. The accuracy of measured values and other data generated by the product is guaranteed as described in the product specifications.
4. In the event that the product or AC adapter malfunctions during its respective warranty period due to a defect of workmanship or materials, Hioki will repair or replace the product or AC adapter free of charge.
5. The following malfunctions and issues are not covered by the warranty and as such are not subject to free repair or replacement:
 - 1. Malfunctions or damage of consumables, parts with a defined service life, etc.
 - 2. Malfunctions or damage of connectors, cables, etc.
 - 3. Malfunctions or damage caused by shipment, dropping, relocation, etc., after purchase of the product
 - 4. Malfunctions or damage caused by inappropriate handling that violates information found in the instruction manual or on precautionary labeling on the product itself
 - 5. Malfunctions or damage caused by a failure to perform maintenance or inspections as required by law or recommended in the instruction manual
 - 6. Malfunctions or damage caused by fire, storms or flooding, earthquakes, lightning, power anomalies (involving voltage, frequency, etc.), war or unrest, contamination with radiation, or other acts of God
 - 7. Damage that is limited to the product's appearance (cosmetic blemishes, deformation of enclosure shape, fading of color, etc.)
 - 8. Other malfunctions or damage for which Hioki is not responsible
6. The warranty will be considered invalidated in the following circumstances, in which case Hioki will be unable to perform service such as repair or calibration:
 - 1. If the product has been repaired or modified by a company, entity, or individual other than Hioki
 - 2. If the product has been embedded in another piece of equipment for use in a special application (aerospace, nuclear power, medical use, vehicle control, etc.) without Hioki's having received prior notice
7. If you experience a loss caused by use of the product and Hioki determines that it is responsible for the underlying issue, Hioki will provide compensation in an amount not to exceed the purchase price, with the following exceptions:
 - 1. Secondary damage arising from damage to a measured device or component that was caused by use of the product
 - 2. Damage arising from measurement results provided by the product
 - 3. Damage to a device other than the product that was sustained when connecting the device to the product (including via network connections)
8. Hioki reserves the right to decline to perform repair, calibration, or other service for products for which a certain amount of time has passed since their manufacture, products whose parts have been discontinued, and products that cannot be repaired due to unforeseen circumstances.

18-07 EN-3

WTY1



1808EN

Edited and published by HIOKI E.E. CORPORATION

Printed in Japan

- CE declarations of conformity can be downloaded from our website.
- Contents subject to change without notice.
- This document contains copyrighted content.
- It is prohibited to copy, reproduce, or modify the content of this document without permission.
- Company names, product names, etc. mentioned in this document are trademarks or registered trademarks of their respective companies.

9:00 ~ 12:00, 13:00 ~ 17:00
土・日・祝日を除く



1801JA

編集・発行 日置電機株式会社

Printed in Japan

- ・ CE 適合宣言は弊社 HP からダウンロードできます。
- ・ 本書の記載内容を予告なく変更することがあります。
- ・ 本書には著作権により保護される内容が含まれます。
- ・ 本書の内容を無断で転記・複製・改変することを禁止します。
- ・ 本書に記載されている会社名・商品名などは、各社の商標または登録商標です。