

MIRO

Power Quality Logger and Analyser

MODELS: PQ25/35/45

User Manual



Contents

1 PRODUCT OVERVIEW	8
1.1 Product brief	8
1.1.1 Feature summary	8
1.1.1.1 Scientific grade	8
1.1.1.2 Compact design	8
1.1.1.3 Power supply options	8
1.1.1.4 All weather conditions	8
1.1.1.5 Safety	8
1.1.1.6 Differential input voltage channels	8
1.1.1.7 Automatic current sensor detection	9
1.1.1.8 Communications	9
1.1.1.9 Software interface	9
1.1.1.10 Transformer monitoring	9
1.1.1.11 DC system monitoring	9
1.1.1.12 Model category	10
1.1.1.13 Expansion port	10
1.1.1.14 Accessories	10
1.1.2 Connections and interfaces	10
1.2 Kits and accessories	12
1.2.1 PQ25/35/45 kits	12
1.2.2 Instruments	12
1.2.3 Accessories	12
1.2.3.1 Current sensors and converters	12
1.2.3.2 Voltage leads and attachments	13
1.2.3.3 Other	14
1.3 Power options	14
1.4 Internal backup battery	14
2 EQUIPMENT MAINTENANCE	15
2.1 Periodic maintenance and testing	15
2.2 Equipment faults	15
2.3 Calibration	15
2.4 Cleaning	15
3 SAFE USE OF THE INSTRUMENT	16
4 INSTALLING YOUR INSTRUMENT	17
4.1 Pre-installation check	17
4.2 Hazard assessment	17
4.3 Live low voltage work	17
4.4 Pole Mounting	17
4.4.1 Using a holster and strap	17
4.4.2 Using a back-plate	18
4.5 Connecting the Miro	18
4.6 Post-installation checks	19

4.7 Disconnecting the Miro	20
5 CITRUS APPLICATION SOFTWARE	21
5.1 Installing the Citrus application software	21
5.2 Connecting to the Miro.....	22
5.3 Online monitor	27
5.3.1 Aggregation interval.....	28
5.3.2 Trigger event.....	28
5.3.3 Sampling rate.....	28
5.3.4 Timestamp	28
5.3.5 RMS and power	28
5.3.6 Phasor diagram.....	29
5.3.7 RMS plot	30
5.3.8 Harmonic magnitude (table)	31
5.3.9 Harmonic magnitude (bar chart).....	32
5.3.10 Harmonic phase.....	35
5.3.11 Harmonic power (bar chart)	35
5.3.12 Interharmonics	36
5.3.13 Flicker	36
5.3.14 Events	37
5.3.14.1 No events.....	37
5.3.14.2 Listed events	38
5.3.14.3 Event information.....	38
5.3.14.4 Trace selection	39
5.3.14.5 Zooming.....	40
5.3.14.6 Examples of RMS and Mains Signalling events.....	41
5.3.14.7 Examples of Coupled Mains Signalling + RMS events	43
5.3.14.8 Combining charts.....	45
5.3.15 Waveforms.....	46
5.4 Configuration	48
5.4.1 General	49
5.4.1.1 Configuration description.....	49
5.4.1.2 Reset to default	49
5.4.1.3 Enable and disable log points.....	49
5.4.1.4 Log start and stop date-times.....	50
5.4.1.5 Log memory usage	50
5.4.1.6 Load from and save to file	50
5.4.1.7 Save configuration to device	50
5.4.2 Inputs	50
5.4.2.1 Nominal frequency.....	50
5.4.2.2 Nominal voltage	51
5.4.2.3 Circuit connection	51
5.4.2.4 Channels.....	51
5.4.2.5 High sensitivity coil	51
5.4.3 Log intervals.....	52
5.4.4 RMS and Power.....	53
5.4.5 Harmonics & Flicker.....	54
5.4.6 Mains Signalling.....	54
5.4.7 IEC events	55
5.4.8 Capture triggers	56

5.4.9 Capture types.....	56
5.4.10 LCD pages	57
5.4.10.1 Information.....	57
5.4.10.2 RMS.....	57
5.4.10.3 Current sensor types	57
5.4.10.4 Temperature	58
5.4.10.5 Power.....	58
5.4.10.6 Power factor	58
5.4.10.7 Flicker	58
5.4.10.8 Phasor diagram	58
5.4.10.9 Voltage waveform.....	58
5.4.10.10 Current waveform	58
5.4.10.11 User page	58
5.4.10.12 Comms status.....	58
5.4.10.13 GPS status	59
5.4.10.14 Common page information	59
5.4.11 Comms.....	60
5.4.11.1 Australian mobile phone networks band summary	60
5.4.11.2 Cellular module.....	61
5.4.11.3 Cellular option outside Australia	61
5.5 Downloading and clearing memory.....	61
5.5.1 Downloading data	61
5.5.2 Downloading with clear memory.....	65
5.6 Clearing memory	67
5.7 Set time	68
5.8 Firmware update.....	68
5.9 Miro data viewer	68
5.9.1 File	70
5.9.1.1 Open	70
5.9.1.2 Add file.....	71
5.9.1.3 Remove file.....	72
5.9.1.4 Exit.....	73
5.9.2 View	74
5.9.2.1 Save view to log file	74
5.9.2.2 Load saved view	75
5.9.2.3 Set zoom.....	76
5.9.2.4 Cursors	79
5.9.2.5 Add title.....	86
5.9.2.6 Add notes as footer	88
5.9.2.7 Add text annotation.....	89
5.9.2.8 Add arrow annotation	91
5.9.2.9 Toggle split/combine.....	94
5.9.2.10 Toggle date /time mode.....	98
5.9.2.11 Close tabs.....	100
5.9.3 Export.....	102
5.9.3.1 Print	102
5.9.3.2 Generate PDF.....	103
5.9.3.3 Generate PNG	104
5.9.3.4 Generate SVG	104

5.9.3.5	Copy to clipboard.....	104
5.9.3.6	Generate CSV	105
5.9.3.7	Generate table.....	106
5.9.4	Measurements	107
5.9.4.1	RMS and frequency.....	107
5.9.4.2	Power and unbalance.....	114
5.9.4.3	Harmonics.....	121
5.9.4.4	Flicker	123
5.9.4.5	Temperature	125
5.9.5	Events.....	126
5.9.5.1	Event filters	127
5.9.5.2	Event selection via up /down buttons	129
5.9.5.3	Combining charts.....	130
5.9.5.4	Trace selection	131
5.9.5.5	Reload button	131
5.9.5.6	Voltage as % of nominal.....	131
5.9.5.7	Add title.....	132
5.9.5.8	Add cursors.....	133
5.9.5.9	Clipboard	134
5.9.5.10	Print	134
5.9.5.11	Export PDF	135
5.9.5.12	Export table	136
5.9.6	Analysis.....	138
5.9.6.1	Harmonic average	138
5.9.6.2	Harmonic compliance	139
5.9.6.3	Voltage compliance	144
5.9.6.4	Energy	150
5.9.6.5	Daily min / max	152
5.9.6.6	ITI (CBEMA) curve	153
5.9.7	View Configuration.....	155
5.9.7.1	Multiple configurations.....	155
5.9.8	Device information	156
5.9.9	Notes.....	156
5.9.10	Tools	158
5.9.10.1	Merge open files	158
5.9.10.2	Split file	159
5.9.11	Options.....	161
5.9.11.1	Time zones	161
5.9.11.2	Colour settings.....	162
5.9.12	Help.....	163
5.9.13	Graph setup	164
5.9.13.1	Log intervals	164
5.9.13.2	Channel filter	164
5.9.13.3	Display values	164
5.9.13.4	Date filter	164
5.9.13.5	Graphical output	170
5.9.13.6	Timeframes.....	171
5.9.13.7	Event summary.....	172
5.9.14	Version number.....	174
5.10	Offline configuration.....	174

6 TROUBLESHOOTING.....	177
6.1 The Miro does not start up after applying power	177
6.2 The Miro does not display voltage and/or current values	177
6.3 The Miro displays incorrect voltage/current values	177
6.4 The Miro LCD shuts down immediately after removing power	177
6.5 The Miro does not communicate with the PC using Citrus software	178
6.6 The Miro date and time are not correct	178
7 SUPPORT SERVICES.....	179
7.1 Operational information	179
7.2 Firmware and software upgrades.....	179
7.3 Technical sales and assistance	179
7.4 Calibration	179
7.4.1 Acceptance testing	179
7.4.1.1 Voltage calibrators	179
7.4.1.2 Suitable voltage sources	182
7.5 Equipment maintenance	182
7.6 Cleaning and decontamination	182
8 INSTRUMENT SPECIFICATIONS.....	184
8.1 Hardware specifications.....	184
8.2 Software features	187
9 ACCESSORIES.....	188
9.1 Voltage leads.....	188
9.1.1 Single phase leads	188
9.1.2 Three phase leads	188
9.1.3 PQ35 three phase leads	189
9.1.3.1 VL3	189
9.1.3.2 VL4	189
9.1.3.3 VL4 voltage lead attachments	190
9.1.3.4 VL6	191
9.1.4 PQ45 three phase leads	192
9.1.4.1 VL5-B.....	192
9.1.4.2 VL5-C.....	193
9.1.4.3 VL8-B.....	194
9.1.4.4 VL8-C.....	195
9.2 Current probes.....	196
9.2.1 PQ35 current probes	196
9.2.1.1 Flexible high sensitivity coil F-500/3000 (Red).....	196
9.2.1.2 Flexible coil 3000 (Blue)	196
9.2.1.3 Flexible coil 3000 (Green)	197
9.2.1.4 Clamp on CT probes 52mm - 100A.....	197
9.2.1.5 Clamp on CT probes 52mm - 500A.....	198
9.2.1.6 Clamp on CT probes 52mm - 1000A.....	198
9.2.1.7 Clamp on CT probes 15mm - 100A.....	199
9.2.1.8 Clamp on AC + DC probes 50mm	199
9.2.2 PQ45 current probes	200
9.2.2.1 Flexible high sensitivity coil F-500/3000 (Red).....	200

9.2.2.2	Flexible coil 3000 (Blue)	200
9.2.2.3	Flexible coil 3000 (Green)	201
9.2.2.4	Clamp on CT probes 52mm - 100A.....	201
9.2.2.5	Clamp on CT probes 52mm - 500A.....	202
9.2.2.6	Clamp on CT probes 52mm - 1000A.....	202
9.2.2.7	Clamp on CT probes 15mm - 10A.....	203
9.2.2.8	Clamp on CT probes 15mm - 100A.....	203
9.2.2.9	Clamp on AC + DC probes 50mm.....	204
9.3	Temperature probes	205
9.4	Antennas	206
9.4.1	GPS antennas.....	206
9.4.2	Cellular antennas.....	206
9.4.3	Combined GPS + Cellular antennas.....	206
9.5	Other	207
9.5.1	DC power adaptor.....	207
9.5.2	Communications cable	207
9.5.3	Carry bag	207
10	INSTRUMENT VOLTAGE CONNECTOR PINOUTS	208
10.1	PQ25 and PQ35	208
10.2	PQ45	209
11	CIRCUIT CONNECTIONS	210
11.1	Star/Wye.....	210
11.1.1	Three phase 4 wire Wye source with Wye load (VL4 cable)	210
11.1.2	Three phase 4 wire Wye source with Wye load (VL5 cable)	211
11.1.3	Three phase 4 wire Wye source with Wye load (VL6 cable)	212
11.2	Delta.....	213
11.2.1	Three phase 3 wire Delta source with Delta load (VL3 cable)	213
11.2.2	Three phase 3 wire Delta source with Delta load (VL6 cable)	214
11.2.3	Three phase 3 wire Delta source with Delta load (VL8 cable)	215
11.2.4	Three phase 2-Watt 3 wire Delta source with Delta load (VL3 cable)	216
11.2.5	Three phase 2-Watt 3 wire Delta source with Delta load (VL6 cable)	217
11.2.6	Three phase 2-Watt 3 wire Delta source with Delta load (VL8 cable)	218
11.3	Split phase.....	219
11.3.1	Split phase 3 wire with 2 single phase loads (VL4 cable)	219
11.3.2	Split phase with 2 single phase loads (VL5 cable)	220
11.3.3	Split phase 3 wire with 2 single phase loads (VL6 cable)	221
11.4	Single phase.....	222
11.4.1	Single phase (VL4 cable).....	222
11.4.2	Single phase (VL5 cable).....	223
11.4.3	Single phase (VL6 cable).....	224
11.5	Generic.....	225
11.5.1	3 independent circuits (VL6 cable)	225
11.5.2	4 independent circuits (VL8 cable)	226

1 Product overview

1.1 Product brief

The MIRO Class A range of portable power quality (PQ) recorders are precision instruments that offer comprehensive and reliable compliance monitoring of low voltage circuits. Built for high performance, toughness and focus on ease of use, the MIRO range are the workhorse instruments of choice for a variety of power monitoring applications including power quality analysis, supply compliance checks and voltage investigations, power flow studies, energy audits, photovoltaic – solar, railway systems, and transformer monitoring.

1.1.1 Feature summary

1.1.1.1 Scientific grade

Designed to Class A, IEC61000-4-30.

1.1.1.2 Compact design

The MIRO PQ is designed to meet applications for the modern marketplace and where space and accessibility are restrictive.

1.1.1.3 Power supply options

Powered from Phase A and external DC.

1.1.1.4 All weather conditions

Rugged, shock resistant, portable and weatherproof (IP66).

1.1.1.5 Safety

- Voltage transients: Minimum CAT IV 600V safety category
- > 10kV isolation to ground
- > 10kV isolation between voltage channels
- Removable voltage leads
- Voltage leads independently certified to CAT IV 600V
- Reinforced insulation / double insulated

1.1.1.6 Differential input voltage channels

All voltage channels are isolated from each other and so no common neutral exists. Each voltage channel has a differential input, two wires, an active and its own neutral. This feature provides much flexibility for monitoring various independent circuit configurations and circuit elements simultaneously which is not possible with a common neutral.

Single ended input

Figure 1.1.1.6.1 shows three single ended channels A, B and C and where each channel has single voltage wire inputs (V1, V2 and V3) with a shared return wire.

Differential input

Figure 1.1.1.6.2 shows three differential channels A, B and C and where each channel requires two voltage wires (V1+ and V1-), (V2+ and V2-) and (V3+ and V3-).

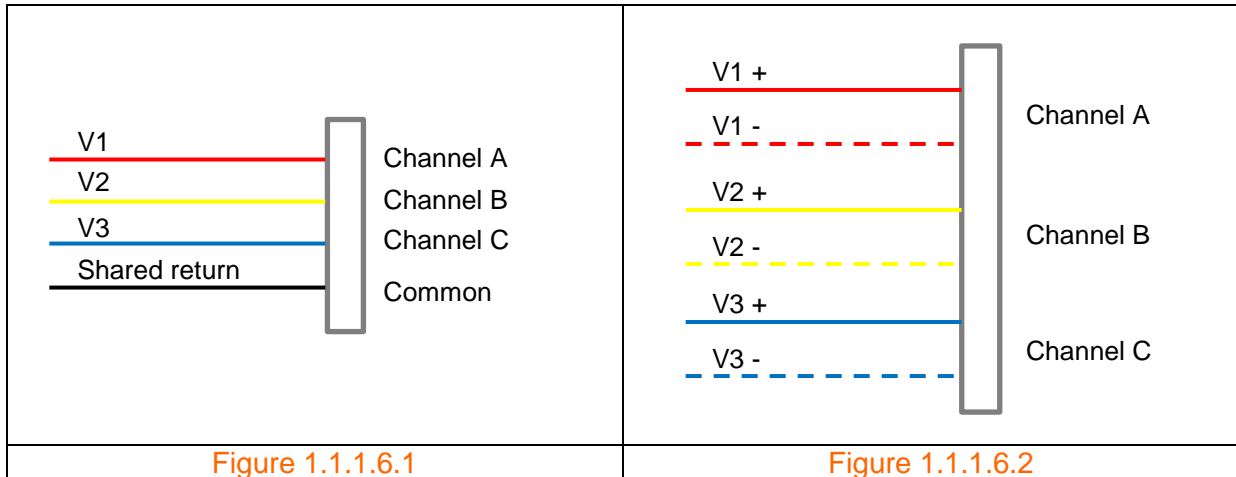

With the Miro the positive wire is assigned as the active phase whilst the negative wire is assigned the return.

1.1.1.7 Automatic current sensor detection

The current channels can accept Rogowski coils, clamp-on CTs and DC probes. The instrument automatically detects and identifies the current sensor and scales the current accordingly. No setup required by the user.

1.1.1.8 Communications

All local and remote communications options are integrated within the standard enclosure - no additional peripherals required other than an external antenna. Remote communications options include: 2G/3G/4G and other cellular platforms.

1.1.1.9 Software interface

The CITRUS platform is powerful, easy to use and intuitive application software that supports all CHK PQ products. It provides tools for: device management; data analysis; and reporting.

1.1.1.10 Transformer monitoring

The incorporation of two temperature channels ideally lends the instrument to transformer monitoring applications. Additional measurements specific to transformer monitoring are available upon request.

1.1.1.11 DC system monitoring

Each current and voltage channel (using the appropriate current probe) can also measure DC components and hence extends the instrument applications to photovoltaic and railway systems.

1.1.1.12 Model category

Two model categories: Single phase and three phase versions.

- Single phase:
 - PQ25 (2 voltage and 2 current channels).
- 3 phase:
 - PQ35 (3 voltage and 4 current channels).
 - PQ45 (4 voltage and 4 current channels).

1.1.1.13 Expansion port

This port allows for system expansion to include additional sensors, input/output controls and custom interfaces.

1.1.1.14 Accessories

All Powermonic PM35 and PM45 accessories can be used with the PQ35 and PQ45 models respectively.

1.1.2 Connections and interfaces

Photos in figures 1.1.2.1, 1.1.2.2, 1.1.2.3 and 1.1.2.4 show ports and hardware interfaces of the PQ35 and PQ45.

A: Voltage lead connector. It can accommodate up to four (4) voltages.

B: Current probe connectors. The channels are designated as A, B, C, and N to accommodate three phase systems.

C: Graphical liquid crystal display (LCD). The LCD can be configured to display pages with each page displayed for approximately three seconds. The pages commence to display upon the application of power. Each page includes

D: Data (USB) connector (bottom); External DC power (top).

E: Temperature connectors. Two external temperatures are available for correlating PQ data and temperature measurements.

F: Expansion port. Used for interfacing to other devices.

G: GPS antenna (left); Cellular antenna (right).



Figure 1.1.2.1 - Miro PQ35



Figure 1.1.2.2 - Miro PQ45



Figure 1.1.2.3 - Miro PQ45

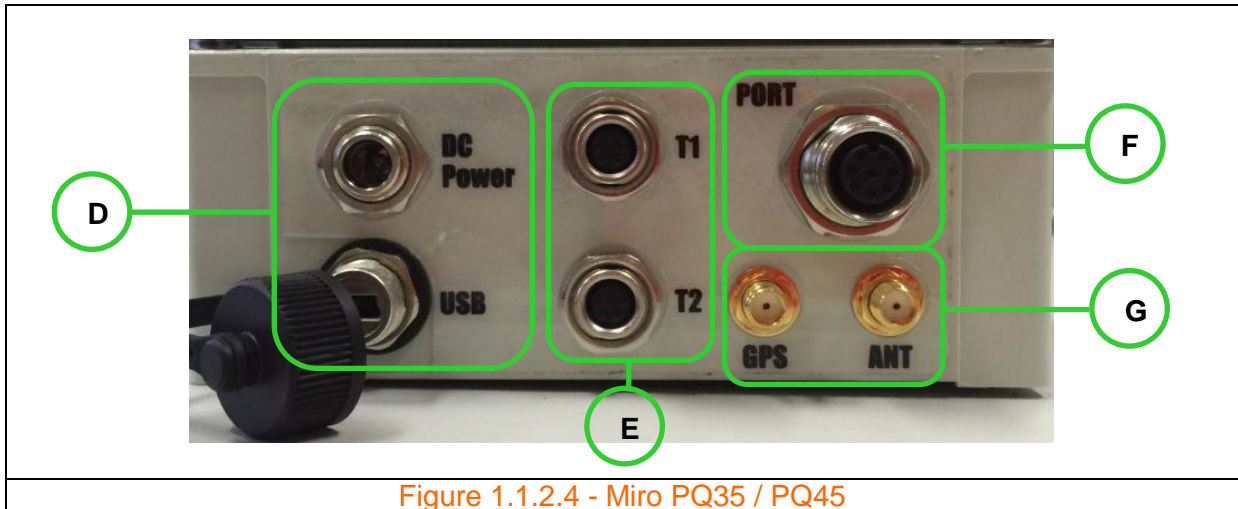

Figure 1.1.2.4 - Miro PQ35 / PQ45

1.2 Kits and accessories

1.2.1 PQ25/35/45 kits

Standard kit for either the PQ25/35/45 includes:

- 1 x power quality instrument
- 4 x high sensitivity flexible current sensors (30-3600)A, 600mm diameter
- 2 x temperature sensors (free end + magnetic mount)
- 1 x set of voltage leads with banana ends with small clamps
- 1 x regulated DC adaptor;
- 1 x single phase power cable
- 1 x carry bag
- 1 x CD (Latest version of CITRUS application software and user manual)

Note that each unit is GPS enabled.

Each kit comprises of accessories with the colour code below.

PQ 25 kit	PQ35 kit	PQ25/35 kit	PQ45 kit	PQ25/35/45 kit	Option
-----------	----------	-------------	----------	----------------	--------

1.2.2 Instruments

Part number	Description	Instrument	Quantity required
1APQ25	PQ25 Power quality logger and analyser	PQ25	1
1APQ35	PQ35 Power quality logger and analyser	PQ35	1
1APQ45	PQ45 Power quality logger and analyser	PQ45	1

1.2.3 Accessories

1.2.3.1 Current sensors and converters

Part number	Description	Instrument	Quantity required
1ACF3000-9	CT 3000A Flexible (100-3600A)	PQ25/35	/4
1ACK1	Converter current 1A:200mA PQ	PQ25/35	1
1ACK5	Converter current 5A:200mA PQ	PQ25/35	1
1ACR100	CT 100A 52mm Iron (10-120A)	PQ25/35	/4
1ACR1000	CT 1000A Clip-on (100-1200A)	PQ25/35	/4
1ACR100S	CT 100A 15mm Iron (10-120A)	PQ25/35	/4
1ACR500	CT 500A 52mm Iron (50-600A)	PQ25/35	/4
1ACF3000-6	CT 3000A, Flexible 600mm (100-3600A) [Blue]	PQ25/35	/4
1ACF3000-6-H	CT 3000A, Flexible 600mm (30-3600A) [Blue]	PQ25/35	/4
1ACF3000-9	CT 3000A, Flexible 900mm (100-3600A) [Blue]	PQ25/35	/4
1AFF3000-6	CT 3000A, Flexible 600mm, 100-3600A Green]	PQ25/35	/4
1AFF500-0.55	Flexible current sensor 500A [Red]	PQ25/35	/4
1AC10	CT 10A 15mm Iron	PQ45	/4
1AC100S	CT 100A 15mm Iron (10-120A)	PQ45	/4
1ASC500	CT 500A 52mm Iron (50-600A) CAT IV 600V	PQ45	/4
1AF3000-6	CT 3000A, Flexible 600mm (100-3600A) [Blue]	PQ45	/4
1AF3000-6-H	CT 3000A, Flexible 600mm (30-3600A) [Blue]	PQ45	/4
1AF3000-9	CT 3000A, Flexible 900mm (100-3600A) [Blue]	PQ45	/4
SAF3000-B	CT 3000A, Flexible 600mm (100-3600A) [Green]	PQ45	/4

1.2.3.2 Voltage leads and attachments

Part number	Description	Instrument	Quantity required
1APC4	Single phase power lead	PQ25/35	1
1APC5	Single phase power lead	PQ45	1
1AVL3	3-Wire (Delta) voltage cable	PQ35	1
1AVL4C2	4 wire voltage lead with large clamps	PQ25/35	1
1AVL4	4 wire voltage lead (3P+N)	PQ25/35	1
1AAC1NCL/BK	Black voltage clamp lead	VL	1
1AAC1NCL/BU	Blue voltage clamp lead	VL	1
1AAC1NCL/RD	Red voltage clamp lead	VL	1
1AAC1NCL/WH	White voltage clamp lead	VL	1
1AVL6		PQ35	1
1AAC6BC-1	Banana plug fused attachment	PQ35	1
1AAC6BC-2	Banana plug fused attachment	PQ35	1
1AVL5-B	5 wire - banana /small clamps voltage lead	PQ45	1
1AVL5-C	5 wire - large clamps voltage lead	PQ45	1
1AVL8-B	8 wire - banana /small clamps voltage lead	PQ45	1
1AVL8-C	8 wire - large clamps voltage lead	PQ45	1
10169	2A HRC fuse for voltage cable	VL	4
1AAC4BC	Banana plug fused attachment	VL	1
1AAC4TE	Tinned end fused attachment	VL	1

1.2.3.3 Other

Part number	Description	Instrument	Quantity required
TBA	Regulated DC adaptor	PQ25/35/45	1
TBA	GPS antenna	PQ25/35/45	1
TBA	Cellular antenna	PQ25/35/45	1
TBA	Cellular communications card	PQ25/35/45	1
TBA	WiFi communications card	PQ25/35/45	1
TBA	CITRUS Lite application Software	PQ25/35/45	1
TBA	CITRUS application Software CD	PQ25/35/45	1
TBA	User manual PQx5	PQ25/35/45	1
1ACBP4	Cary bag	PQ25/35/45	1
SA7002-A	Temperature sensor (free end)	PQ25/35/45	1
SA7002-M	Temperature sensor (magnetic mount)	PQ25/35/45	1
TBA	USB communications lead for PQx5	PQ25/35/45	1
TBA	DC probe 500A	PQ25/35/45	/4
TBA	3.2V 1.5Ah backup battery for PQx5	PQ25/35/45	1
TBA	3.2V 3.2Ah backup battery for PQx5	PQ25/35/45	1

1.3 Power options

The MIRO can be powered in the following ways:

- **Voltage channel A:**
 - Single supply cable adaptor; or
 - Voltage clamp lead.
- **External DC supply:** DC adaptor provided.
- **USB port:** Only for configuration and data download.

1.4 Internal backup battery

The Miro is powered by a single rechargeable Lithium iron phosphate battery 3.2V 1.5Ah or 3.2Ah as shown in figures 1.4.1 and 1.4.2.

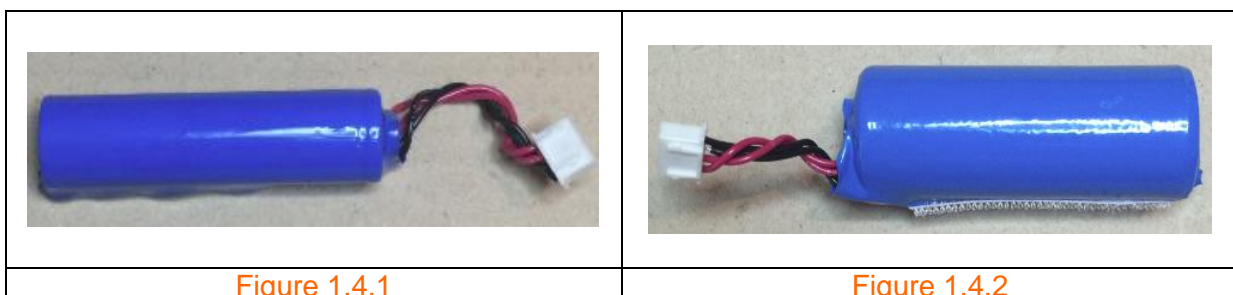

The instrument is factory set for a standard back-up time of 5 minutes after which it switches itself off. The instrument can be pre-configured for extended back-up times. Please contact CHK Power Quality Pty Ltd for more information.

2 Equipment maintenance

The Miro PQ25/35/45 instrument should be regularly tested and maintained to make sure the equipment and leads are in proper working condition and fit for purpose.

2.1 Periodic maintenance and testing

The Miro and accessories should be inspected, tested and tagged as per the normal procedures of your employer or responsible body.

2.2 Equipment faults

If the equipment is found to be faulty in any way, including suspected blown fuses, it should be returned to CHK Power Quality Pty Ltd for service.

2.3 Calibration

The Miro should be calibrated every twelve (12) months.

2.4 Cleaning

The Miro, voltage leads, and current probes should be cleaned with a soft, moist cloth using only a mild detergent.

After cleaning, ensure that all equipment is thoroughly dry before use. Check that all connectors and connector receptacles are completely dry.

3 Safe use of the instrument

If you require assistance with any instructions in this manual, please contact CHK Power Quality Pty Ltd.

The Miro is intended to be used on energised lines or equipment. Personnel using equipment on energised lines must be authorised by the relevant regulatory bodies to carry out such work and must have appropriate training.

The information given in this document is given as a guide only. It is the user's responsibility to ensure that correct and safe procedures are followed at the actual work site. CHK Power Quality Pty Ltd offers no warranty or indemnity for accidents that may occur when following these instructions.

Prior to using a Miro, you should note the following:

- The voltage leads have internal field replaceable HRC fuses. Refer to Section 10.6 on troubleshooting if you suspect a blown fuse.
- If the Miro and accessories are used in a manner not specified in this manual, the protection provided by the equipment may be impaired.
- The Miro should not be immersed in water or other fluids. The Miro should not be used in explosive atmospheres.
- When any voltage clamp/plug is connected to a hazardous live conductor, the other voltage clamp/plugs should also be treated as live, due to the internal measurement impedance of the Miro.
- Connectors should be properly connected to their receptacles, using their screw or push fastener
- The outer sheath of all leads should be free from damage, with no inner insulation showing. There should be no breakages or cracks in the Miro enclosure, the voltage clamps, banana plugs or connectors.
- The Miro is suitable for outdoor measurements only when used with the recommended voltage leads. When other voltage leads are used, the unit is suitable for indoor measurements.
- When used outdoors with the recommended voltage leads, the unit will withstand exposure to rain and fog.
- All voltage leads and current probes should be connected to the Miro before connection to mains conductors.
- Any equipment showing signs of damage should not be used. Return it to CHK Power Quality Pty Ltd.

4 Installing your instrument

4.1 Pre-installation check

- Verify that the nominal voltage to be tested is within the operating range of the Miro as indicated on the front label.
- The A phase supplies power to the Miro (approximately 12 VA).
- Identify the ground (earth), neutral and all phases.
- Ensure the unit will be physically secured against movement.
- Ensure that leads will not be damaged when shutting enclosure doors.
- Internal mounting locations should be chosen so that the temperature limits are not exceeded.
- External mountings should be such that there can be no access by the public.

4.2 Hazard assessment

Prior to using the Miro, the operator must carry out a work site, pre-job hazard assessment to identify the safety and environmental needs. This must be done prior to commencing work and prior to recommencing work after leaving and returning to the work site. Refer to the safety procedures provided by your employer or responsible body.

4.3 Live low voltage work

For the correct and safe use of this equipment, it is essential that all operating personnel follow appropriate safety procedures. Check your relevant employer or responsible body's rules for working with live equipment.

4.4 Pole Mounting

When installing a Miro on a pole, hang the instrument in a suitable location and ensure that it is safely secured using the holster and strap or back-plate provided.

4.4.1 Using a holster and strap

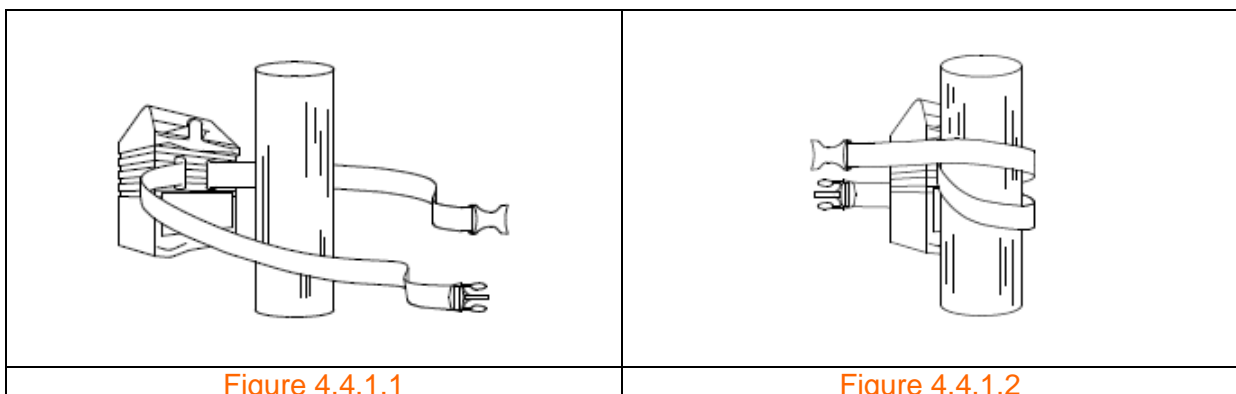

Step 1: The strap is first fed through the holster slats and wrapped around the pole as shown in figure 4.4.1.1.

Step 2: Bring the strap forward to embrace the Miro as shown in figure 4.4.1.2.

Step 3: Wrap the strap around the post and secure the Miro with the quick release clip at the rear as shown in figure 4.4.1.3.

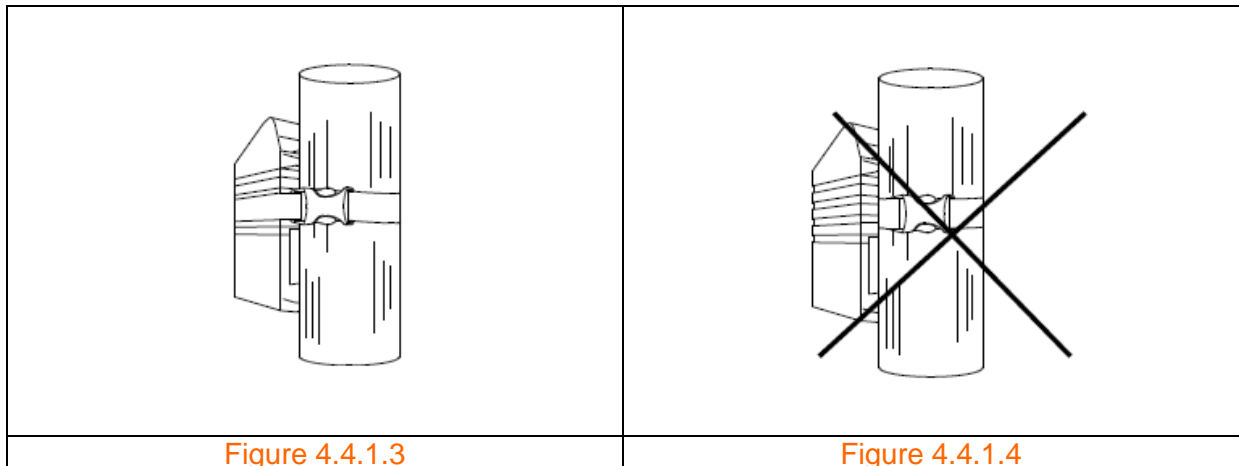

Do not connect the Miro to the pole without embracing the unit with the strap, as this may weaken the holster over time; refer to figure 4.4.1.4.

4.4.2 Using a back-plate

Step 1: Screw the optional back-plate provided to the back of the Miro case using four stainless steel M5 x 16mm pan screws as illustrated in figures 4.4.2.1 and 4.4.2.2.

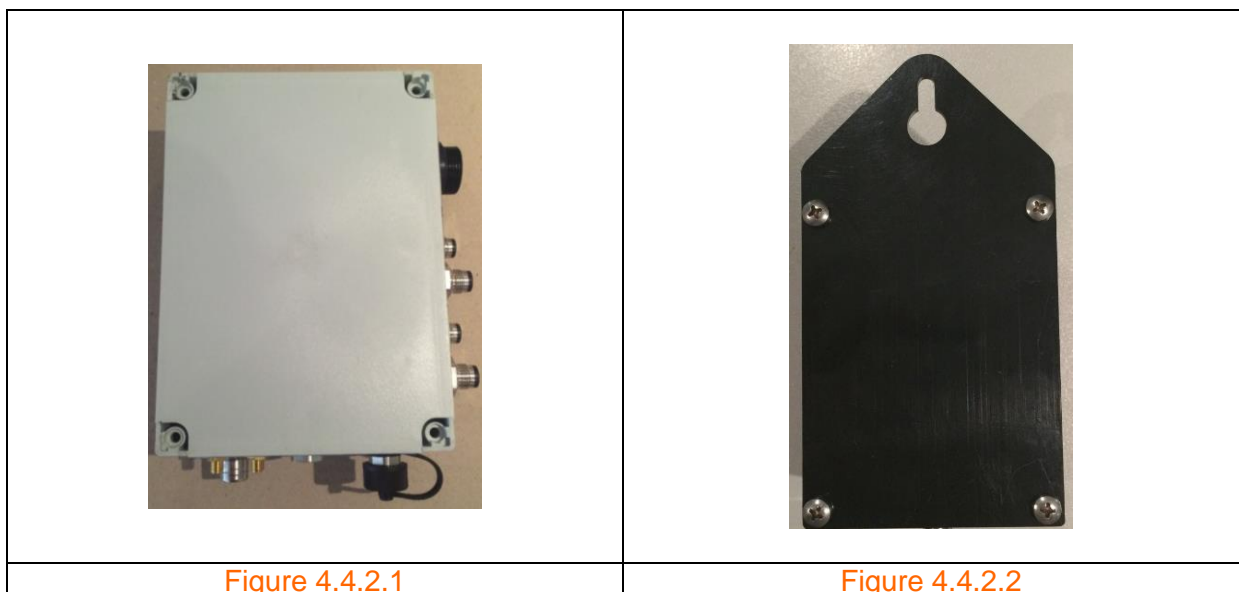

4.5 Connecting the Miro

Connect the appropriate voltage lead to the Miro. The voltage connector is keyed. Screw up the locking ring to ensure the connector does not inadvertently become disconnected.

Connect the appropriate current probes to the Miro. These connectors are keyed. Screw on the locking rings to ensure that the connectors do not become inadvertently disconnected.

When any voltage clamp/plug is connected to a hazardous live conductor, the other voltage clamp/plugs should also be treated as live, due to the internal measurement impedance of the Miro.

When attaching the connectors to the Miro, ensure the connectors and receptacles on the Miro are completely dry.

To ensure accurate power measurements, it is important that the current probes are connected to the same phases as the voltage leads. For example, the A phase voltage must be measured by the A phase voltage clamp and the A phase current probe must measure the A phase current. Current probe arrows should point to the load to ensure accurate power measurement.

Connect the current probes first, making sure that:

- They are connected to the appropriate phase; and
- The arrow markings point towards the load.

PQ25/35

Connect the voltage clamps in the following order:

- PC4: Insert the plug in the GPO and switch it on;
- VL4: Neutral, Phase C, Phase B, Phase A; and
- VL6: Neutral C, Phase C, Neutral B, Phase B, Neutral A, Phase A.

PQ45

Connect the voltage clamps in the following order:

- PC5: Insert the plug in the GPO and switch it on;
- VL5-C and VL5-B: Ground, Neutral, Phase C, Phase B, Phase A; and
- VL8-B: Ground, Neutral, Neutral C, Phase C, Neutral B, Phase B, Neutral A, Phase A.

The Miro is powered from the Phase A to Neutral connection, and will commence logging once the A phase connection is made. It will draw power approximately 12 VA from the A phase.

4.6 Post-installation checks

- Ensure that voltage clamps and current probes are secure and not likely to move or dislodge.
- Check that all leads are secure and will not be damaged when equipment doors are closed.

- The Miro is powered by the A phase voltage. You must connect this phase for the Miro to begin logging.
- Unused voltage clamps should be connected to neutral. (Do not leave the unit unattended with unconnected voltage clamps).
- Before leaving the installation site, check that the voltages and currents displayed on the LCD are reasonable.
- Check that the Miro is logging data by checking that 'LOG: ON' is shown on the bottom right hand corner of the LCD. "Wait" indicates unit is waiting for configured start time. "Fin" indicates that the configured stop time has already passed and unit will not log until reconfigured.

4.7 Disconnecting the Miro

When any voltage clamp/plug is connected to a hazardous live conductor, the other voltage clamp/plugs should also be treated as live, due to the internal measurement impedance of the Miro.

PQ25/35

Disconnect the voltage leads in the following order:

- PC4: Switch off the GPO and remove the plug;
- VL4: Phase A, Phase B, Phase C, Neutral; and
- VL6: Phase A, Neutral A, Phase B, Neutral B, Phase C, Neutral C.

PQ45

Disconnect the voltage leads in the following order:

- PC5: Switch off the GPO and remove the plug;
- VL5-C and VL5-B: Phase A, Phase B, Phase C, Neutral and Ground;
- VL8-B: Phase A, Neutral A, Phase B, Neutral B, Phase C, Neutral C, Neutral, Ground.

Disconnect the current probes.

5 Citrus application software

The Citrus application software is a universal device management tool for all CHK Power Quality products and at present includes the **Mirrin** and **Miro** products.

5.1 Installing the Citrus application software

Step 1: Click on the following link which takes you to the 'Downloads' page of the CHK Power Quality website <http://www.chkpowerquality.com.au/downloads/>

Step 2: On the 'Downloads' page click on 'Citrus Software' as shown in figure 5.1.1.

An executable file, as highlighted by the file icon shown in figure 5.1.2 and appears at the bottom left corner of your screen, will be downloaded to your computer and placed in the 'Downloads' folder.

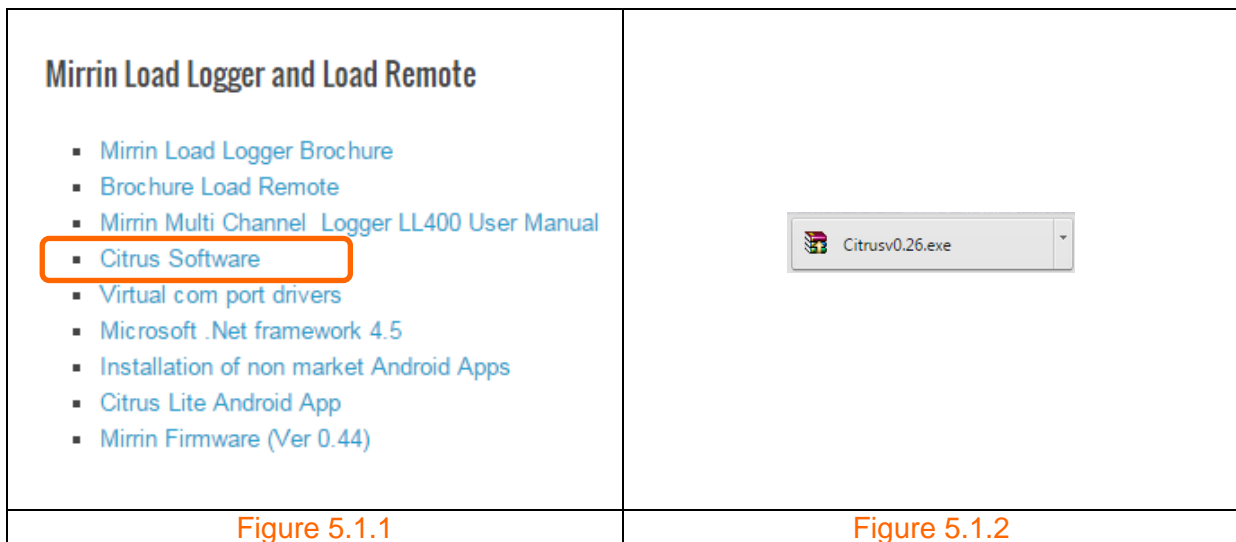

Step 3: Click on the file icon. The form in figure 5.1.3 appears.

Step 4: Click the 'Run' button as shown in figure 5.1.3. The form in figure 5.1.4 appears.

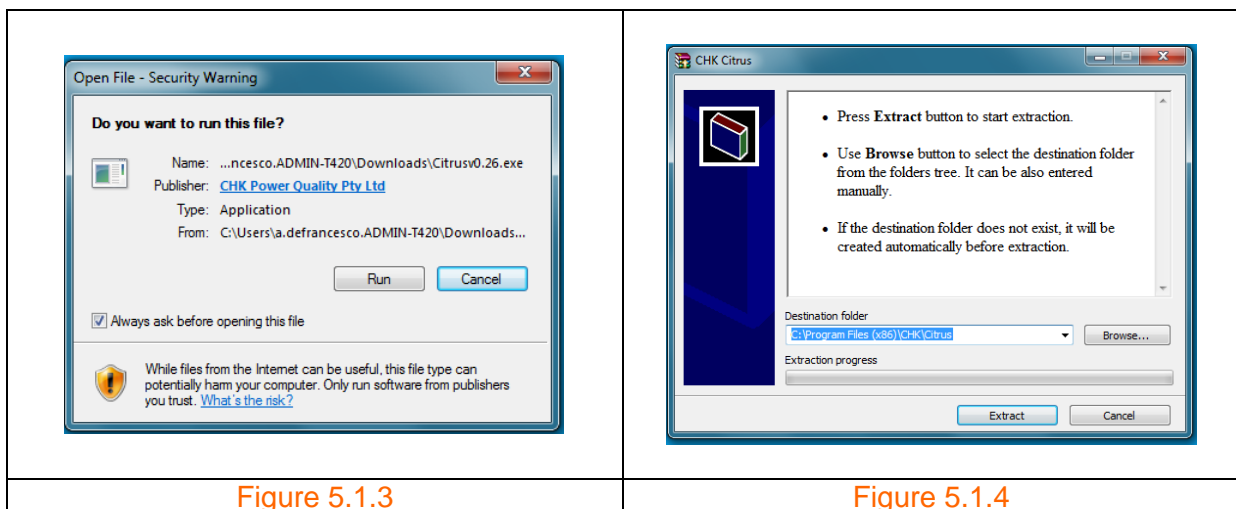

Step 5: Click the 'Extract' button shown in figure 5.1.4 to the desired location. The icon in figure 5.1.5 will appear on your desktop and in the start menu as shown in figure 5.1.6.

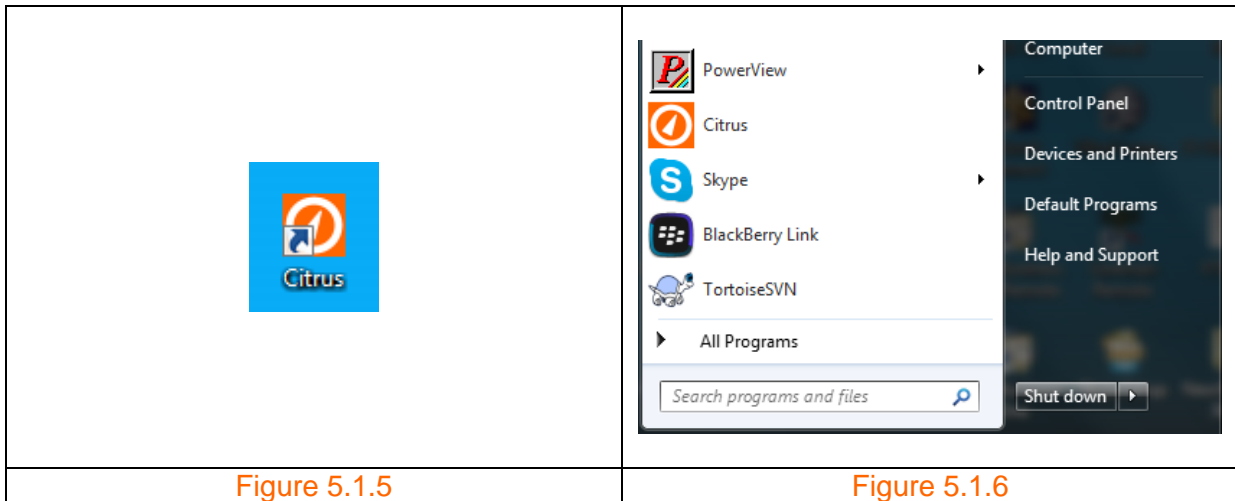

The Citrus application is installed.

5.2 Connecting to the Miro

Step 1: Click on the Citrus icon, shown in figure 5.2.1, in the start menu or double click on the Citrus icon on the desktop to launch the application. The application form 'Citrus v1.01' shown in figure 5.2.2 will appear. Note that the '1.01' is the software version number and will change over time.

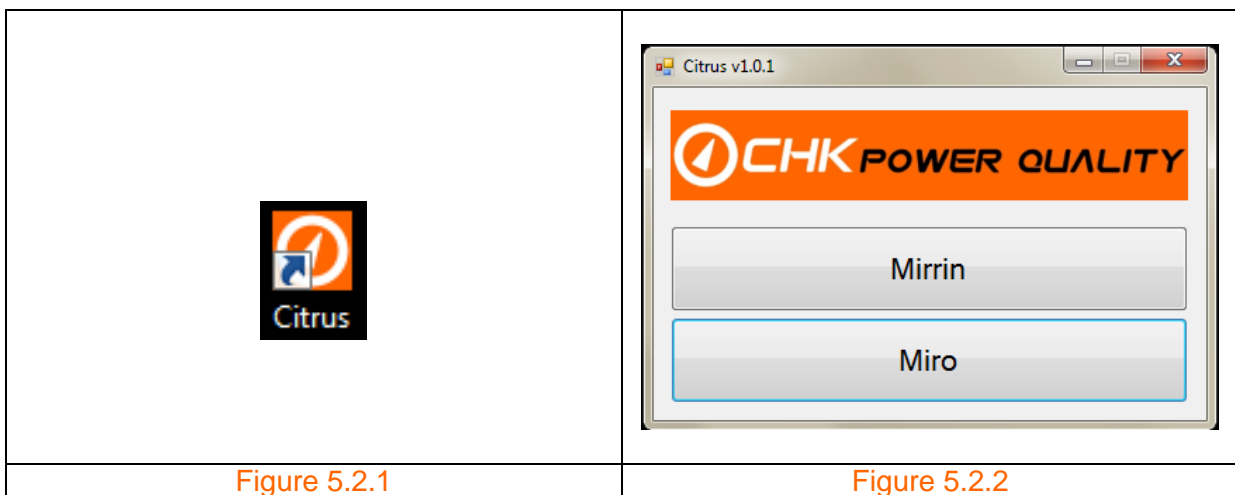

Step 2: Click on the 'Miro' button. The application form shown in figure 5.2.3 will appear. There are four options, 'Open Data File', 'Connect USB', 'Connect TCP/IP', and 'Offline Configuration'.

Note that the 'Connect USB' button is inactive and the message reads 'No Miro detected'.



Figure 5.2.3



Figure 5.2.4

Connect using USB

Step 3: Using the serial cable provided connect one end to a USB port on your PC and the other end to the Data (USB) port of the Miro.

Wait approximately six seconds and note that the 'Connect USB' button, shown in figure 5.2.4 is now active.

The Miro will always power up with the CHK Power Quality branding as shown in figure 5.2.5. If the Miro is only powered from the USB cable, then it will power up in 'USB Mode'. In this mode the graphical updates are disabled and the unit only displays 'USB MODE' as shown in figure 5.2.6.



Figure 5.2.5

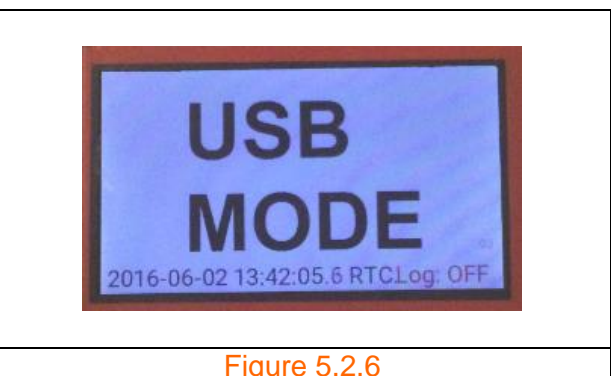

Figure 5.2.6

If the Miro is in 'USB Mode' and then powered from mains supply or an external dc supply without disconnecting from USB, the unit automatically restarts to exit 'USB Mode' (the Miro can only leave 'USB Mode' on a power cycle).

Step 4:

Click the 'Connect USB' button shown in figure 5.2.4. The 'Miro Operations' window shown in figure 5.2.7 appears together with a warning message shown in figure 5.2.8.

The warning message only appears if the detected firmware is outdated. There is no requirement to update the firmware.

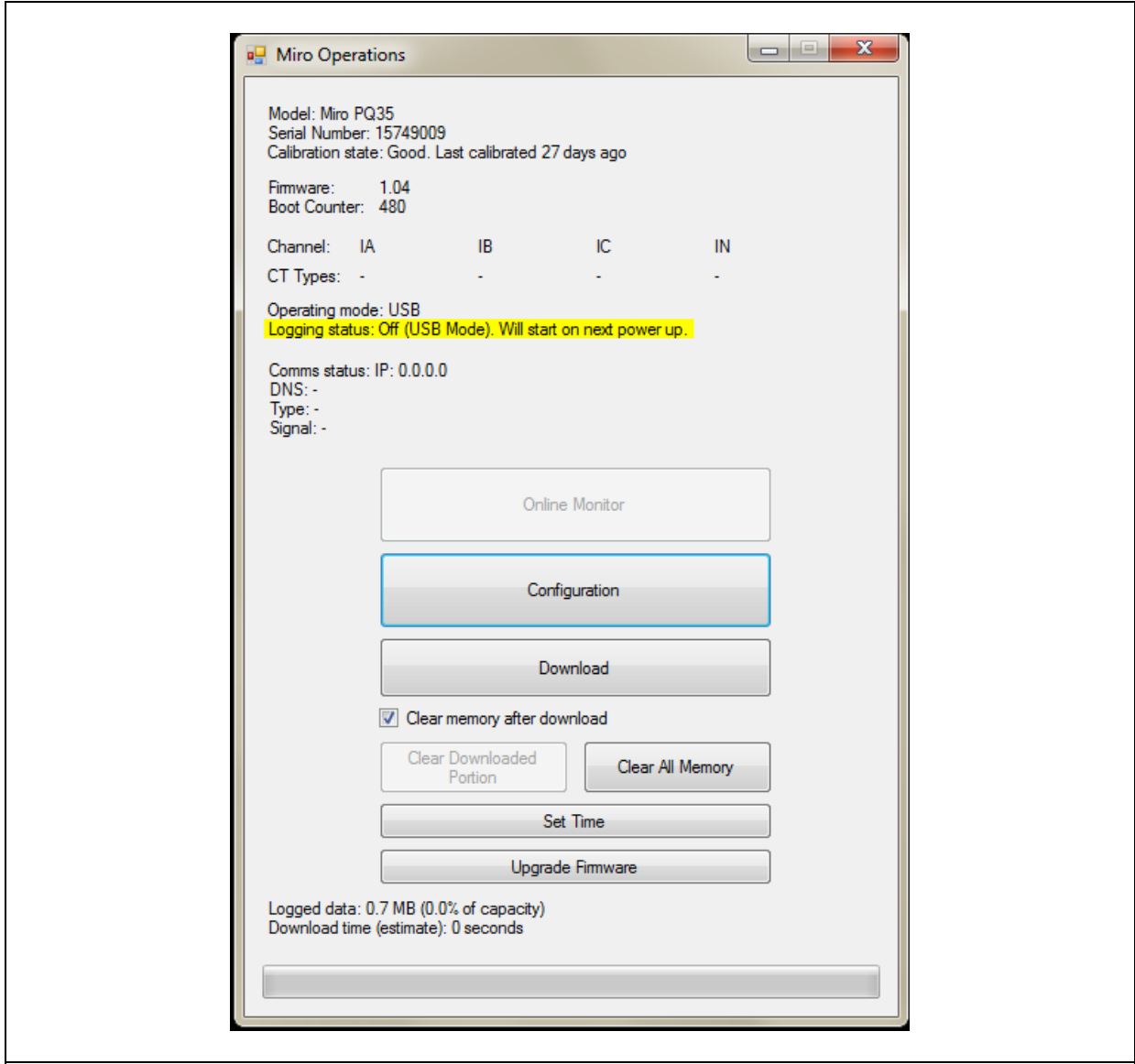

Figure 5.2.7

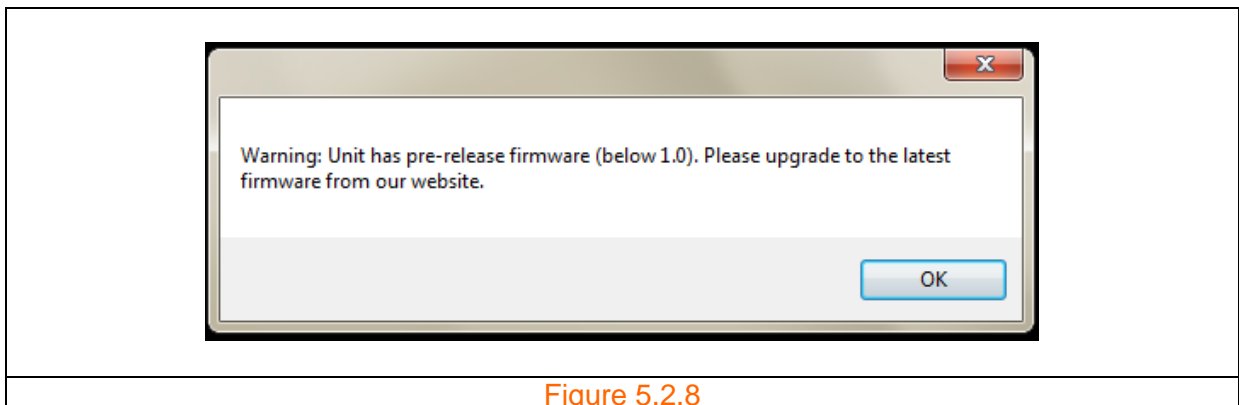

Figure 5.2.8

Step 5:

Click the 'OK' button shown in figure 5.2.8 to proceed.

All tools for managing the Miro are shown on the 'Miro Operations' window.

Note that the 'Online Monitor' button in figure 5.2.7 is inactive and that the 'Logging status' is 'Off'. This is because the Miro is in 'USB Mode'.

As shown in figure 5.2.9, the 'Online Monitor' button is active and the 'Logging status' is 'On' when the Miro is out of 'USB Mode'.

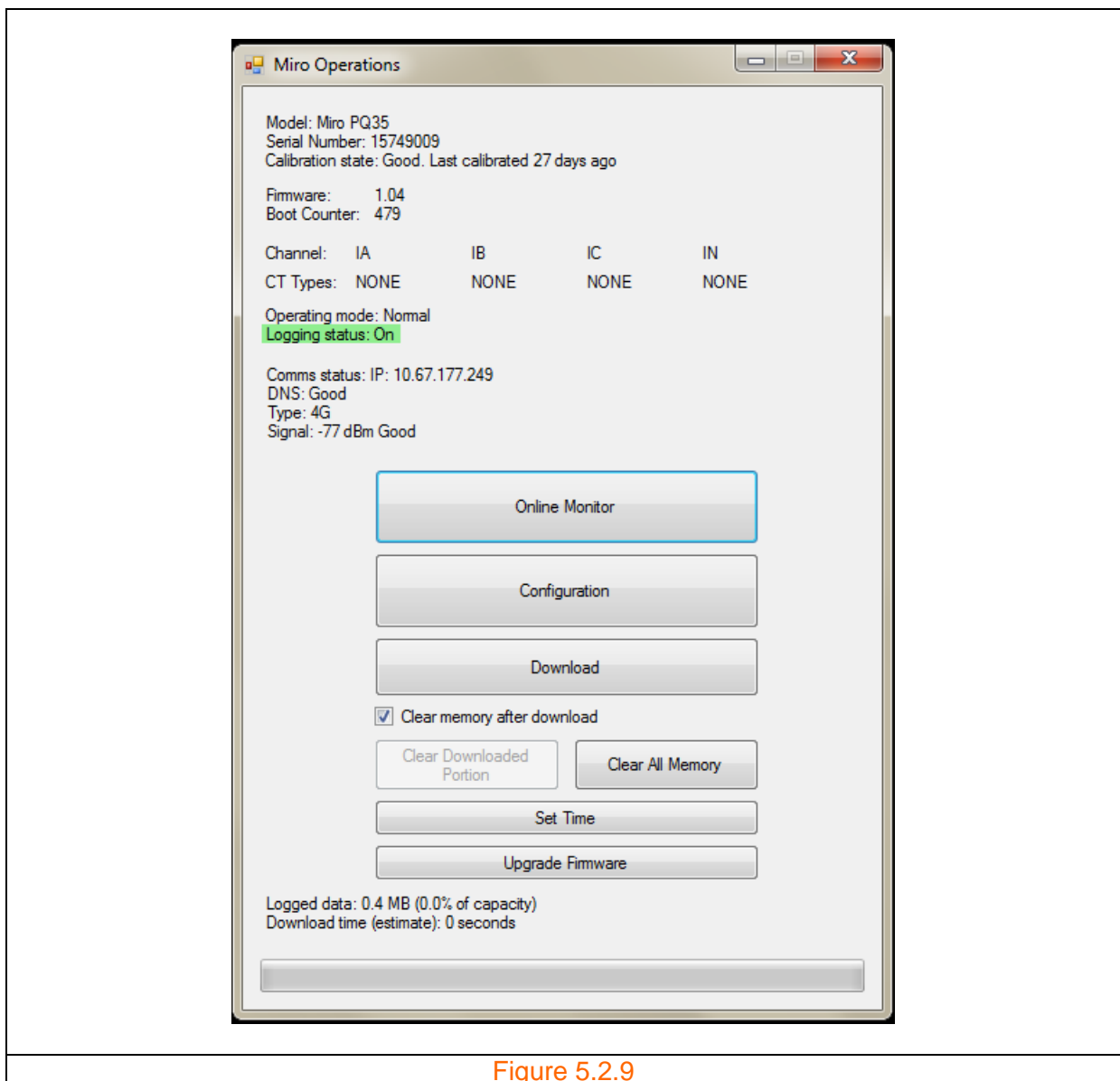

Figure 5.2.9

Note that if the Miro is not in USB mode and all power is removed, the backup battery will sustain the current mode for 5 minutes; after which time the Miro will enter USB mode.

Also note that cellular communications is disabled whilst in USB mode and shown in figures 5.2.7 and 5.2.9.

Connect using an IP address

Use this only for WiFi, Cellular or Ethernet communications.

Click the 'Connect TCP/IP' button shown in figure 5.2.3. A box with a default IP address will appear as shown in figure 5.2.10. Alter the address as required and click the 'Ok' button. The message box shown in figure 5.2.11 will appear if the device could not connect. If connection is established then the 'Miro Operations' window shown in figure 5.2.9 will appear.

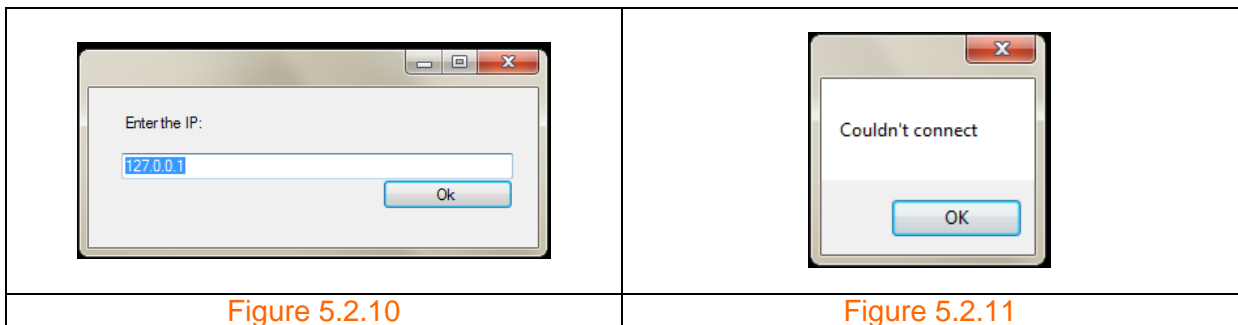

Figure 5.2.10

Figure 5.2.11

Calibration state

Normally the calibration state of the Miro is 'Good', indicating that the Miro is fit for service. If for some reason the Miro is not fit for service then the calibration state will change to 'Bad'.

If 'Last calibrated' exceeds 365 days then the calibration state will change to 'Due', indicating that the Miro should be returned for calibration. If 'Last calibrated' exceeds 800 days then a message box will appear stating that the Miro is 'x days since last calibration', where x is the number of days since last calibration.

If the 10/12 cycle log interval is selected a warning message appears on the 'Miro Operations' window (as shown in figure 5.2.12) alerting the user that this selection will consume memory. As shown in figure 5.2.13, the message disappears when the 10/12 cycle log interval is deselected.

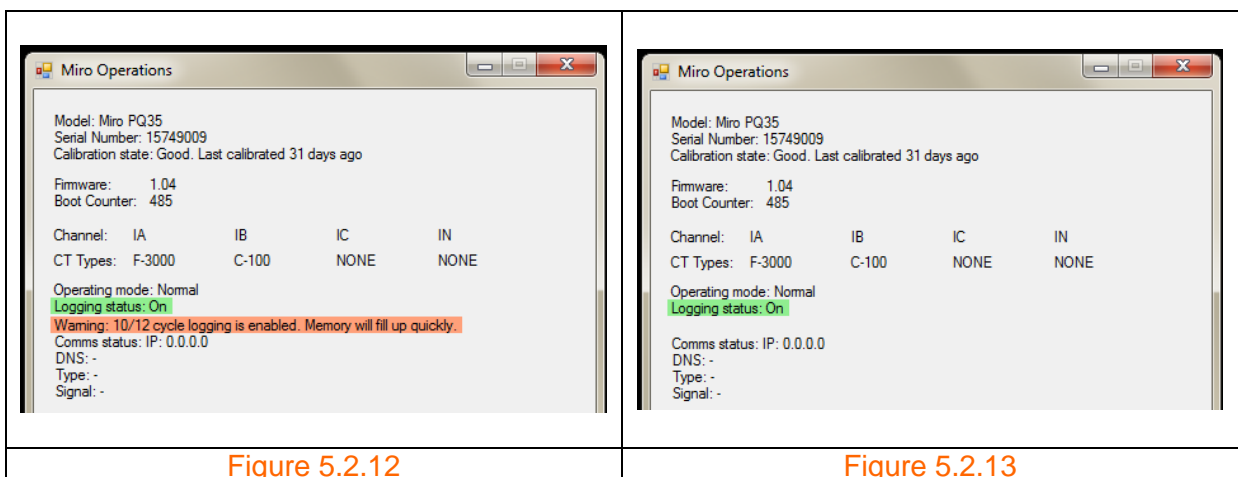

Figure 5.2.12

Figure 5.2.13

The Miro detects the type of current sensor utilised per channel ‘CT Types’ and displays it on the ‘Miro Operations’ window. Figures 5.2.12 and 5.2.13 show that Channels A and B have an ‘F-3000’ sensor (flexible current sensor rated at 3000A) and ‘C-100’ sensor (100A clamp on CT) connected. The ‘CT Types’ will display ‘NONE’ if no sensor is connected or if the sensor is not identified by the Miro.

5.3 Online monitor

The ‘Online Monitor’ tool allows the user to view measurements in quasi real-time without the need for logging.

Step 1: Click on the ‘Online Monitor’ button on the ‘Miro Operations’ window. The ‘Online Monitor’ form appears and provides menu tabs for the various monitoring screens as shown in figure 5.3.1. There are currently ten menu tabs and these include:

- RMS and Power;
- RMS Plot;
- Harmonic Magnitude (table);
- Harmonic Magnitude (bar chart);
- Harmonic Phase;
- Harmonic Power (bar chart);
- Interharmonics;
- Flicker;
- Events; and
- Waveforms.

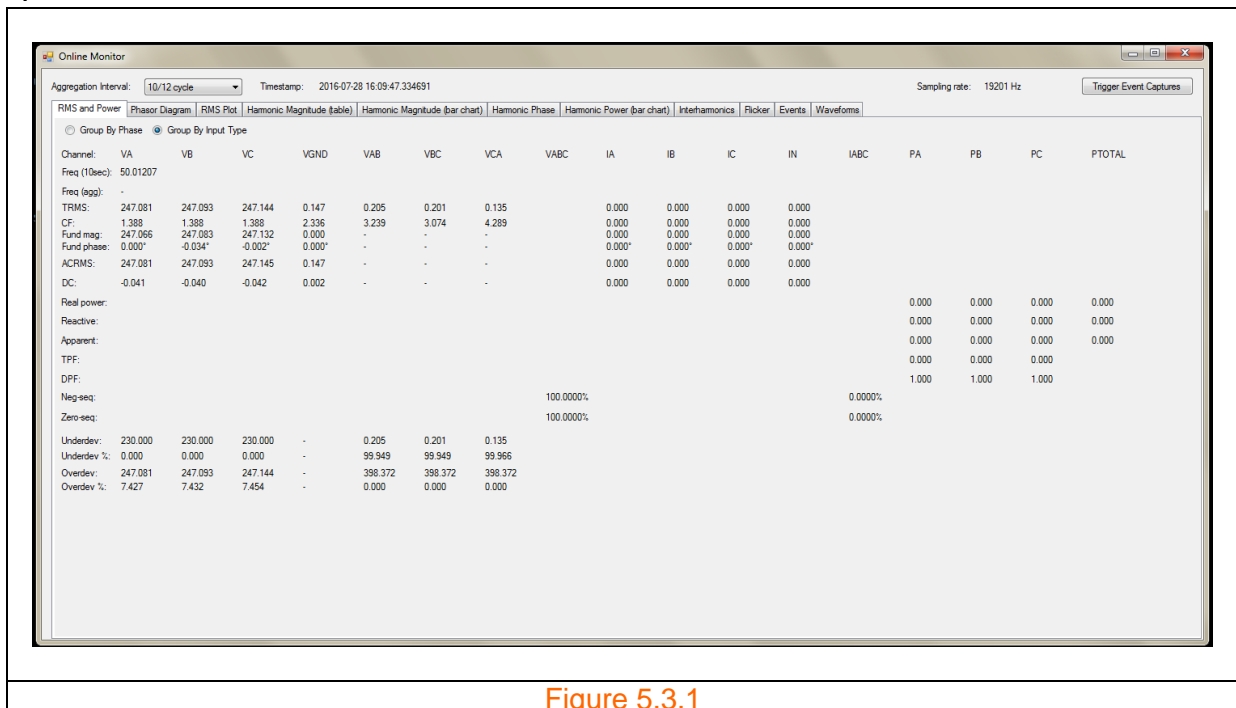

Figure 5.3.1

Items shown above the tabs include: Aggregation Interval; Timestamp; Sampling rate; and the Trigger Event Captures button. These items are visible for all tabs except for Flicker, Events and Waveforms.

5.3.1 Aggregation interval

Clicking on the 'Aggregation Interval' button opens a drop down list box that allows the user to select the desired aggregation interval as shown in figure 5.3.1.1 and hence view values aggregated over the selected interval.

This has no effect on logging; Miro will continue logging as set in the configuration.

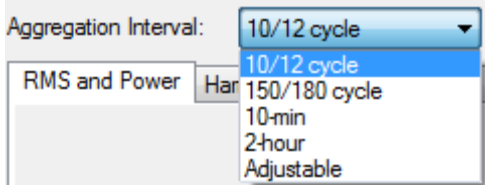
	<p>The aggregations include:</p> <ul style="list-style-type: none"> (i) 10/12 cycle (50Hz / 60Hz); (ii) 150/180 cycle (50Hz / 60Hz); (iii) 10 minute; (iv) 2 hours; and (v) Adjustable.
<p>Figure 5.3.1.1</p>	

5.3.2 Trigger event

The user is able to trigger an event at any time (manual trigger) by clicking on the 'Trigger Event Captures' button as shown in figure 5.3.2.1.

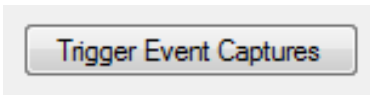
	<p>The result is displayed and viewed in the 'Events' section.</p>
<p>Figure 5.3.2.1</p>	

5.3.3 Sampling rate

The sampling rate as shown in figure 5.3.3.1 is constantly updated and displayed at the top of the form. It has a nominal value of 19.2kHz and synchronised to the mains frequency.

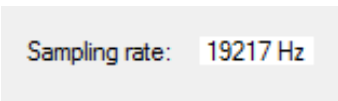
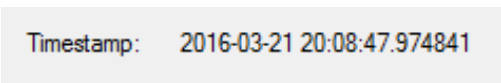
	
<p>Figure 5.3.3.1</p>	<p>Figure 5.3.4.1</p>

5.3.4 Timestamp

The timestamp as shown in figure 5.3.4.1 is constantly updated and displayed at the top of the form.

5.3.5 RMS and power

The 'RMS and Power' screen shown in figure 5.3.1 automatically appears when the 'Online Monitor' button is clicked on the 'Miro Operations' form shown in figure 5.2.9.

Two different views are available, 'Group By Phase' or 'Group By Input Type', with the latter being the default view. The views can be selected by radio buttons as shown in figure 5.3.5.1.

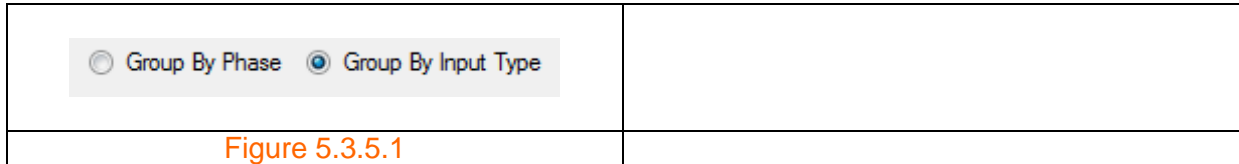

Figure 5.3.5.1

The key power quality parameters are displayed and include:

- (i) Frequency (10 sec.);
- (ii) True RMS values (TRMS);
- (iii) Crest factor (CF);
- (iv) Fundamental magnitude and phase;
- (v) AC RMS;
- (vi) DC value;
- (vii) Real power, Reactive power and apparent power;
- (viii) True power factor (TPF) and displacement power factor (DPF);
- (ix) Negative and zero sequences values; and
- (x) Underdeviation and overdeviation.

5.3.6 Phasor diagram

The 'Phasor Diagram' screen, shown in figure 5.3.6.1, displays a live plot of polar coordinates for both the voltage and current.

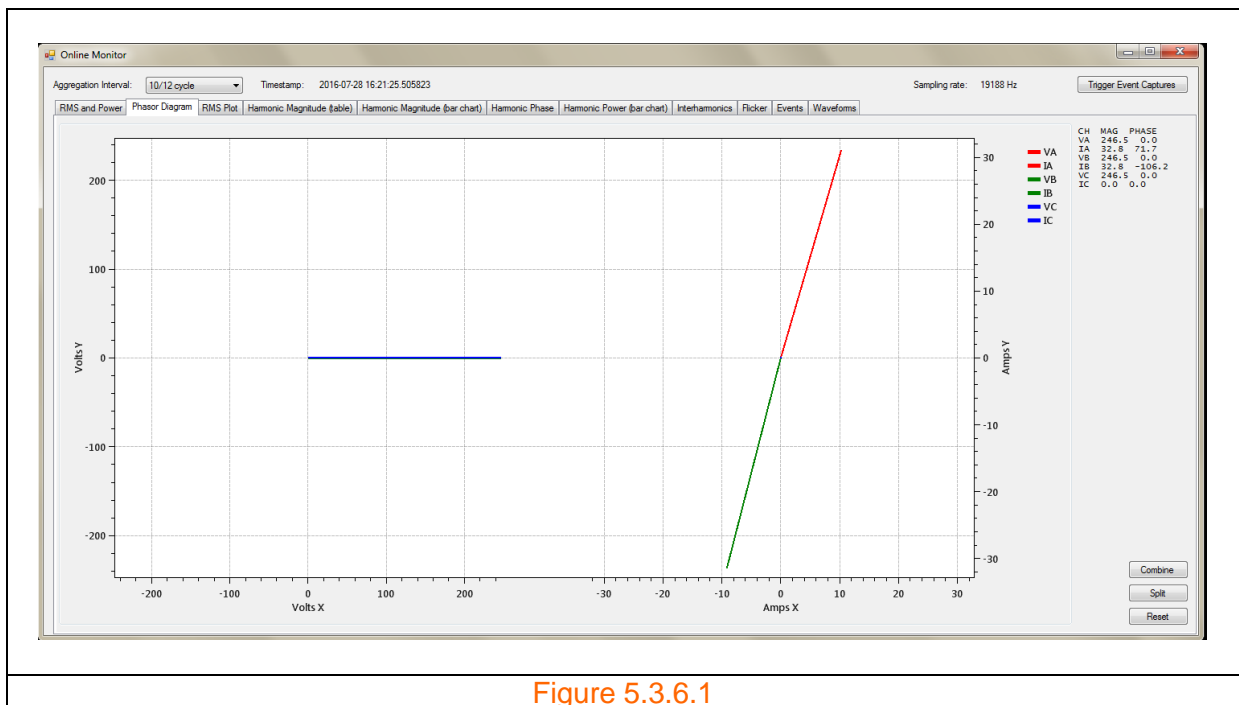

Figure 5.3.6.1

Both the magnitude and phase is displayed for each channel as shown in figure 5.3.6.2.

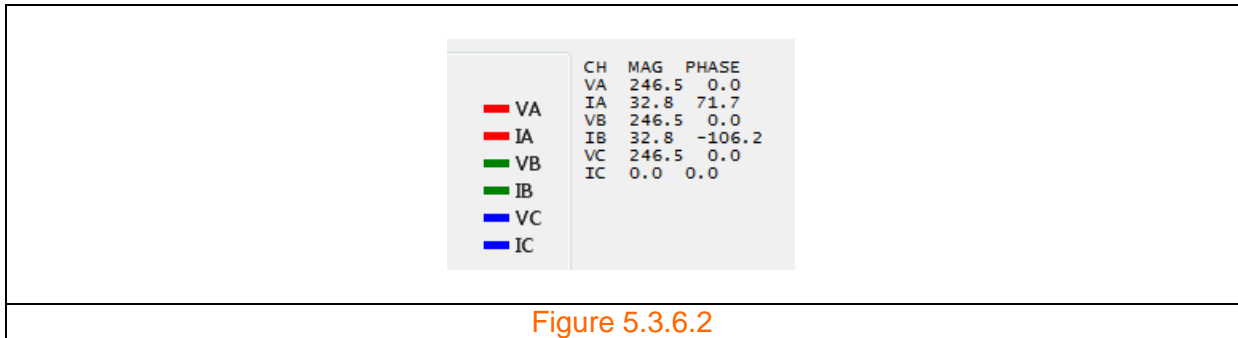

Figure 5.3.6.2

The user has the option to combine the voltage and current phasors onto a single polar plot as shown in figure 5.3.6.3 by clicking the 'Combine' button.

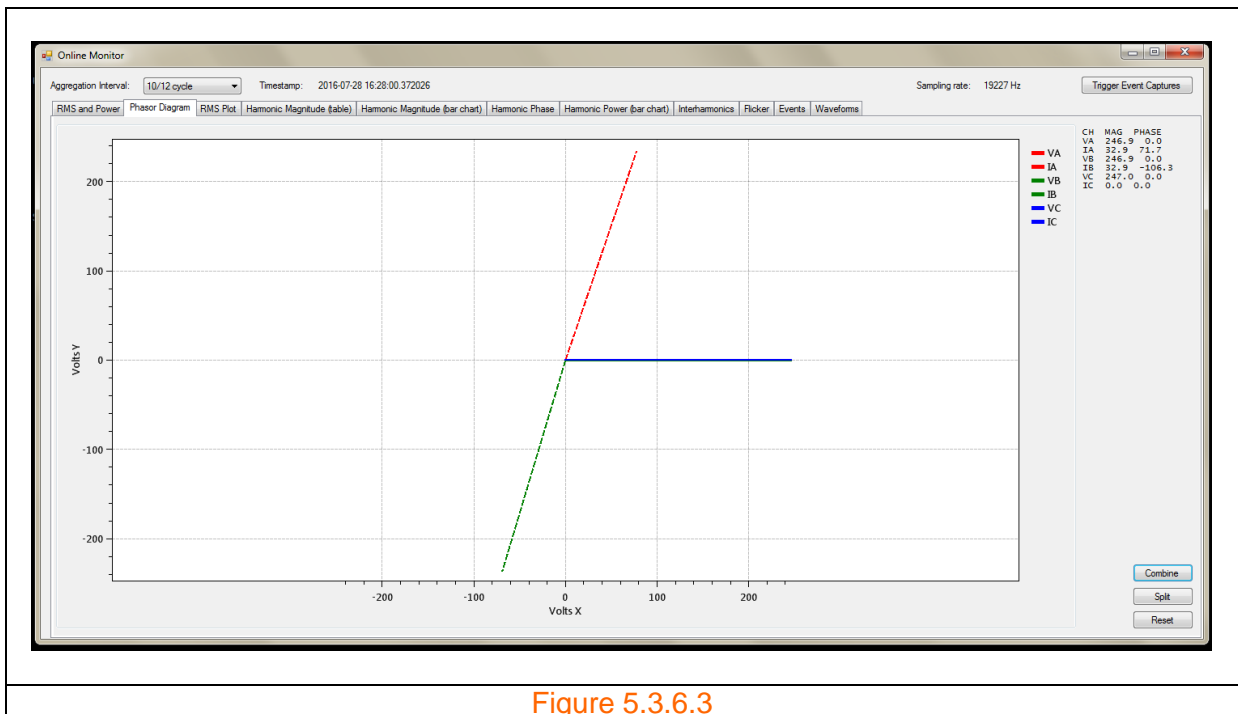

Figure 5.3.6.3

Click on the 'Split' button to separate the plots. The 'Reset' button clears and redraws the graph to a default scale.

5.3.7 RMS plot

The 'RMS Plot' screen, shown in figure 5.3.7.1, displays a live graph of the RMS values which is continuously updated.

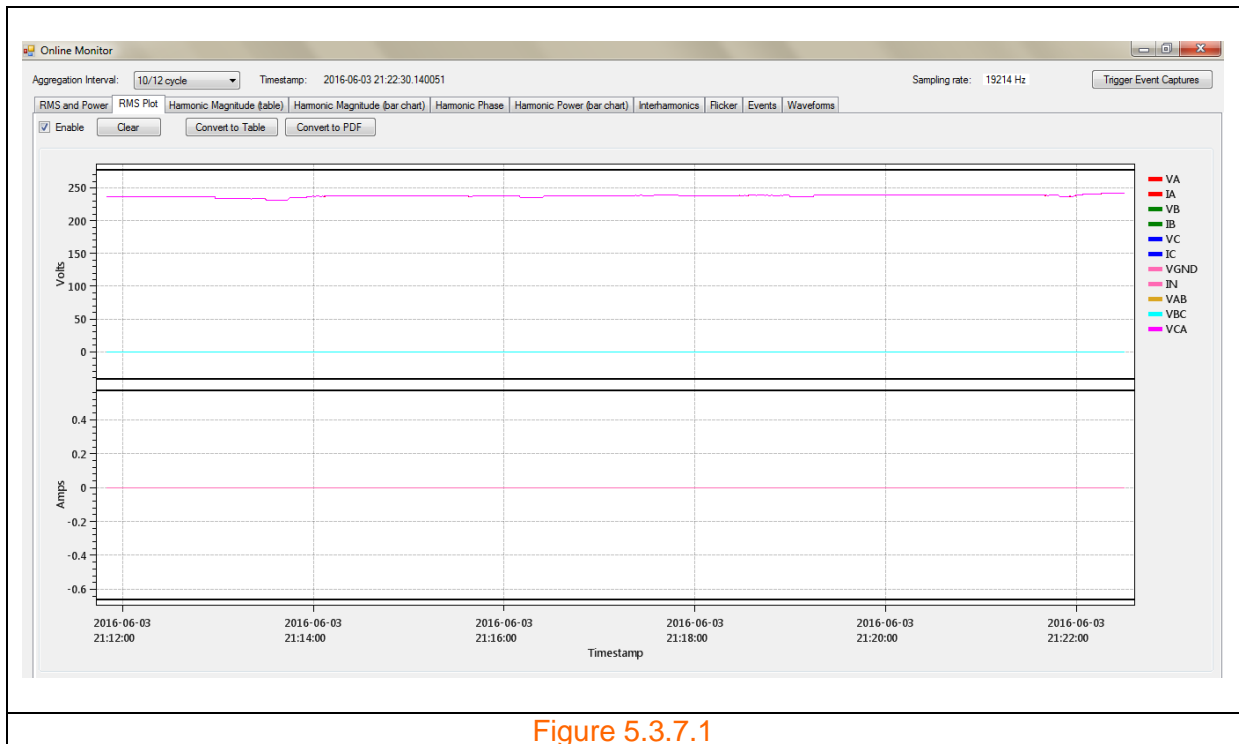

Figure 5.3.7.1

5.3.8 Harmonic magnitude (table)

The 'Harmonic Magnitude (table)' screen displays the rms value for each voltage and current harmonic up to and including the 50th harmonic as shown in figure 5.3.8.1. The total harmonic distortion (THD) is also calculated for each channel.

The user has the option to view values as 'RMS Magnitude' or '% of H1' (percent of fundamental). The default value is set to 'RMS Magnitude'.

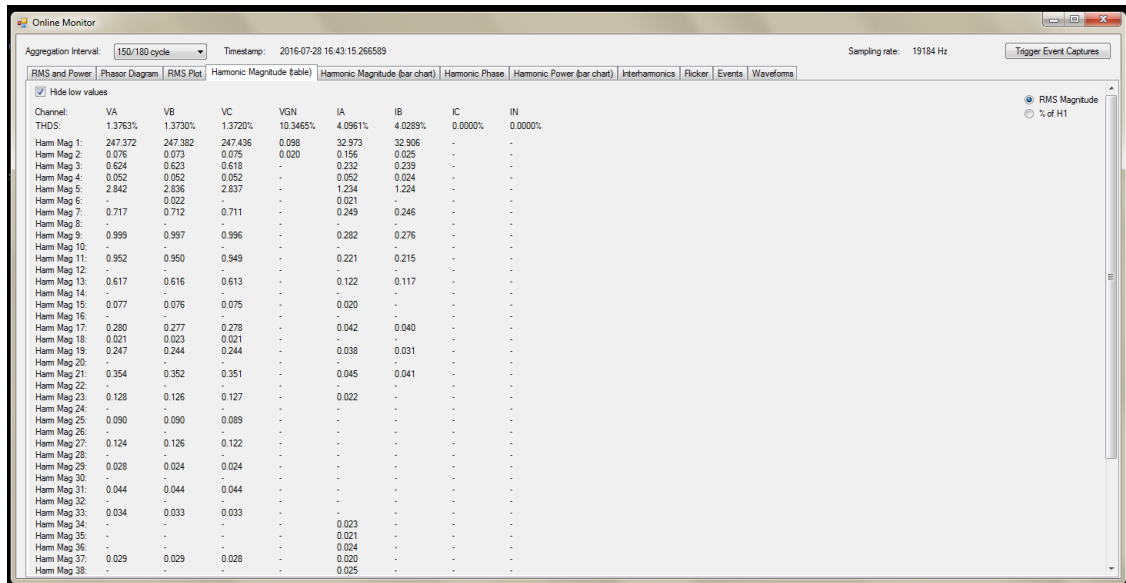

Figure 5.3.8.1

5.3.9 Harmonic magnitude (bar chart)

The 'Harmonic Magnitude (bar chart)' screen displays the rms values of the harmonic spectrum for a range of harmonic numbers. Figure 5.3.9.1 displays the spectrum for harmonic numbers in the range 1-50, which is the default range.

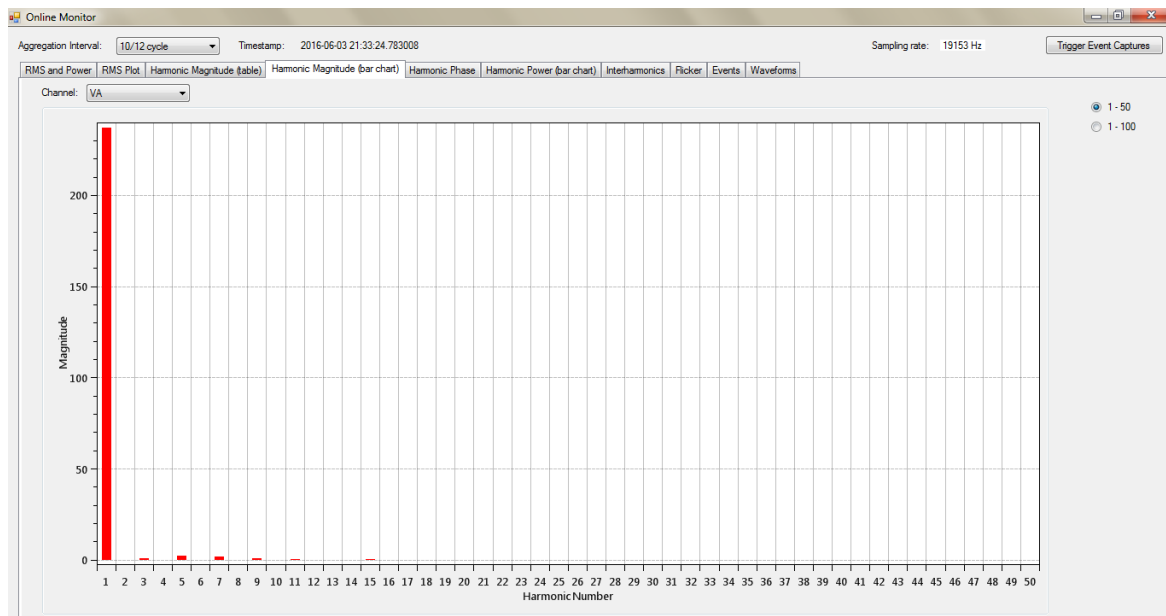
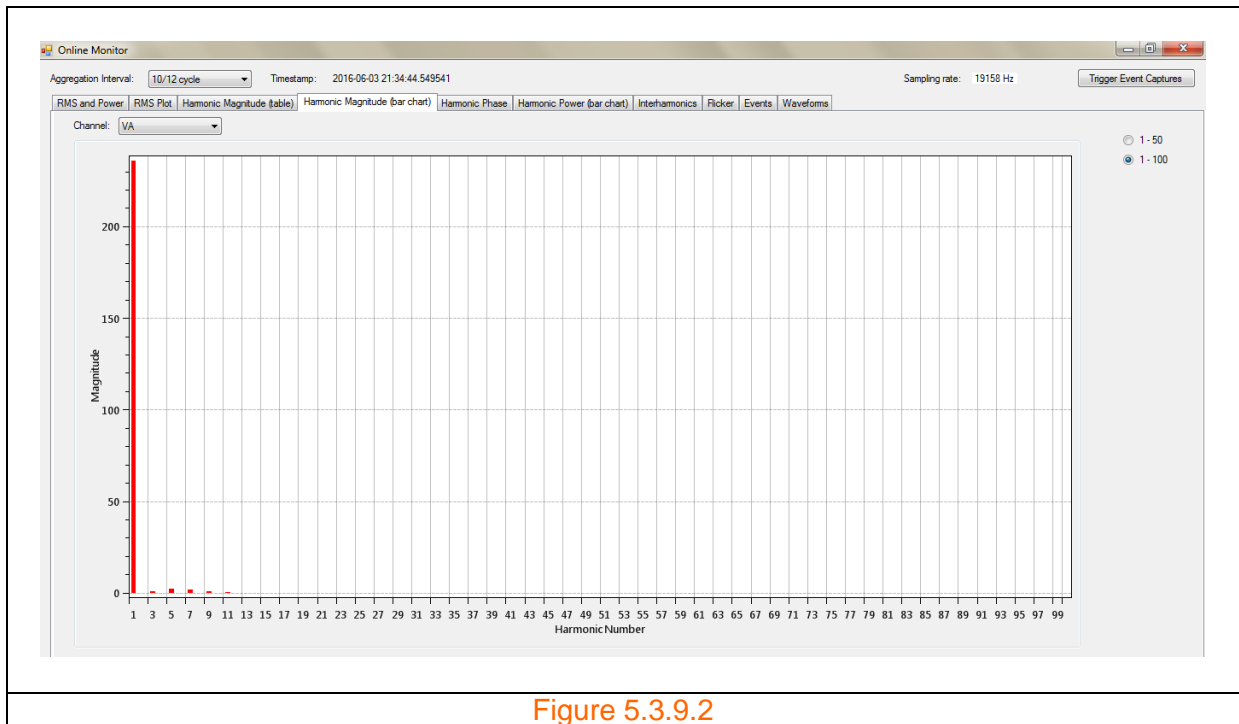

Figure 5.3.9.1

Selecting the '1-100' option changes the range to include the 100th harmonic as shown in figure 5.3.9.2.



The user can zoom into a smaller range of interest by the application of a selection box.

Selection box

Step 1: Move the mouse to the location where you wish to start.

Step 2: Click and hold down the mouse's left button.

Step 3: Drag the mouse to the final location enclosing the harmonics of interest and release the left button as shown in figure 5.3.9.3.

The zoom resulting from the application of the selection box shown in figure 5.3.9.3 is shown in figure 5.3.9.4.

The user can go back to the original chart by double clicking anywhere in the chart area.

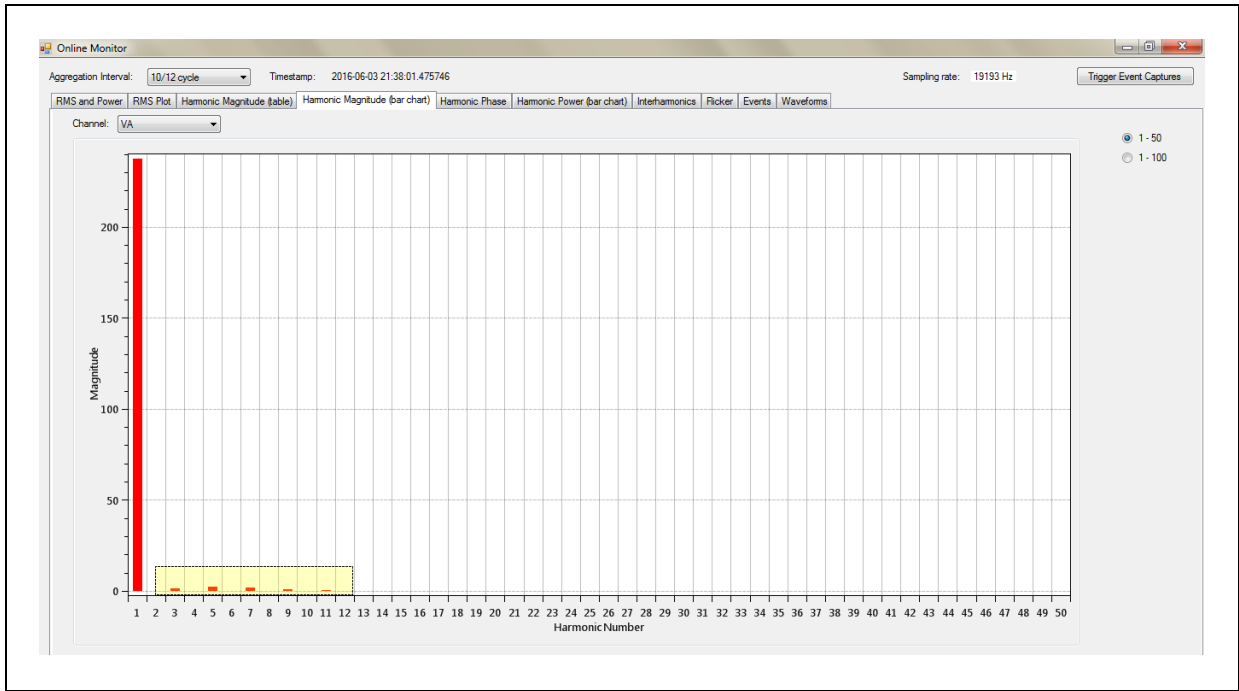

Figure 5.3.9.3

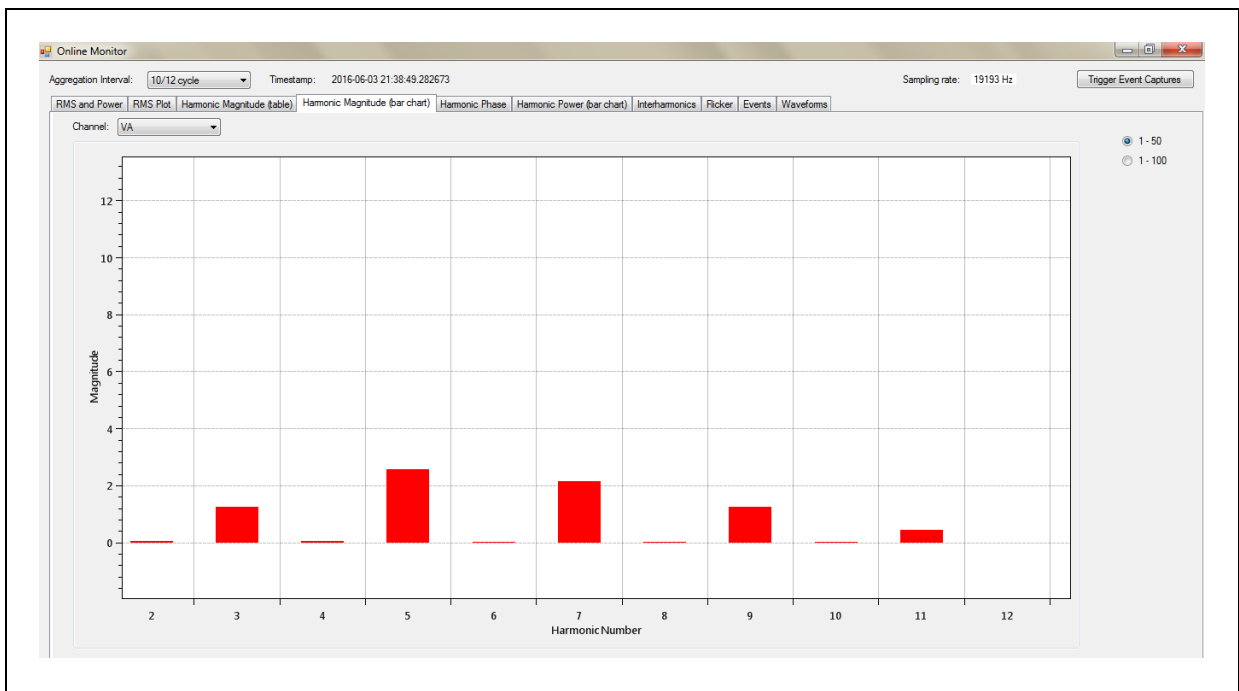
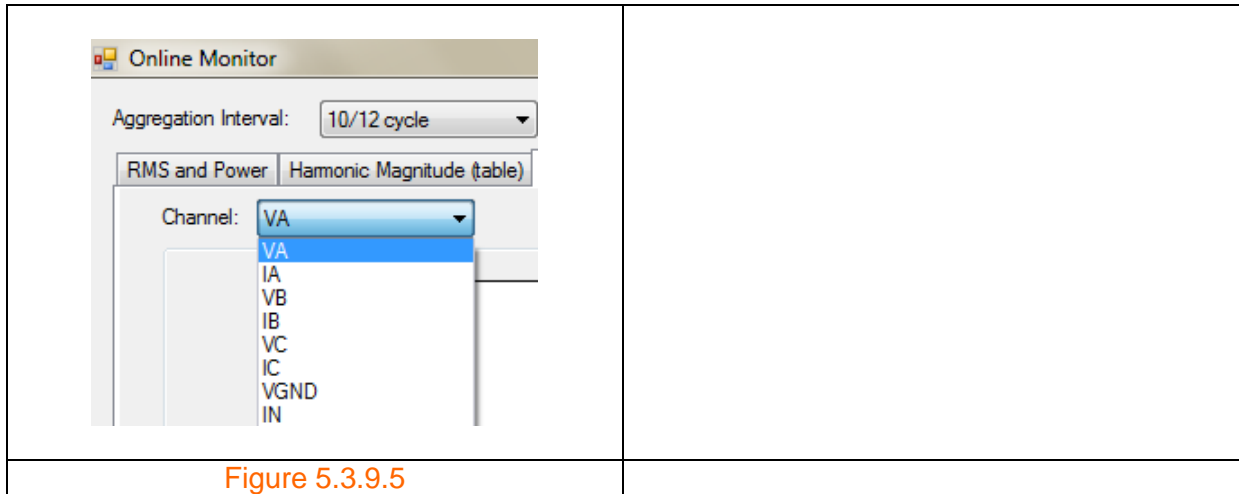

Figure 5.3.9.4

Channel selection is effected by clicking on dropdown list box as shown in figure 5.3.9.5 and selecting either: VA; IA; VB; IB; VC; IC; VGND; or IN.



5.3.10 Harmonic phase

The 'Harmonic Phase' screen displays the phase angle for each voltage and current harmonic up to and including the 50th harmonic as shown in figure 5.3.10.1.

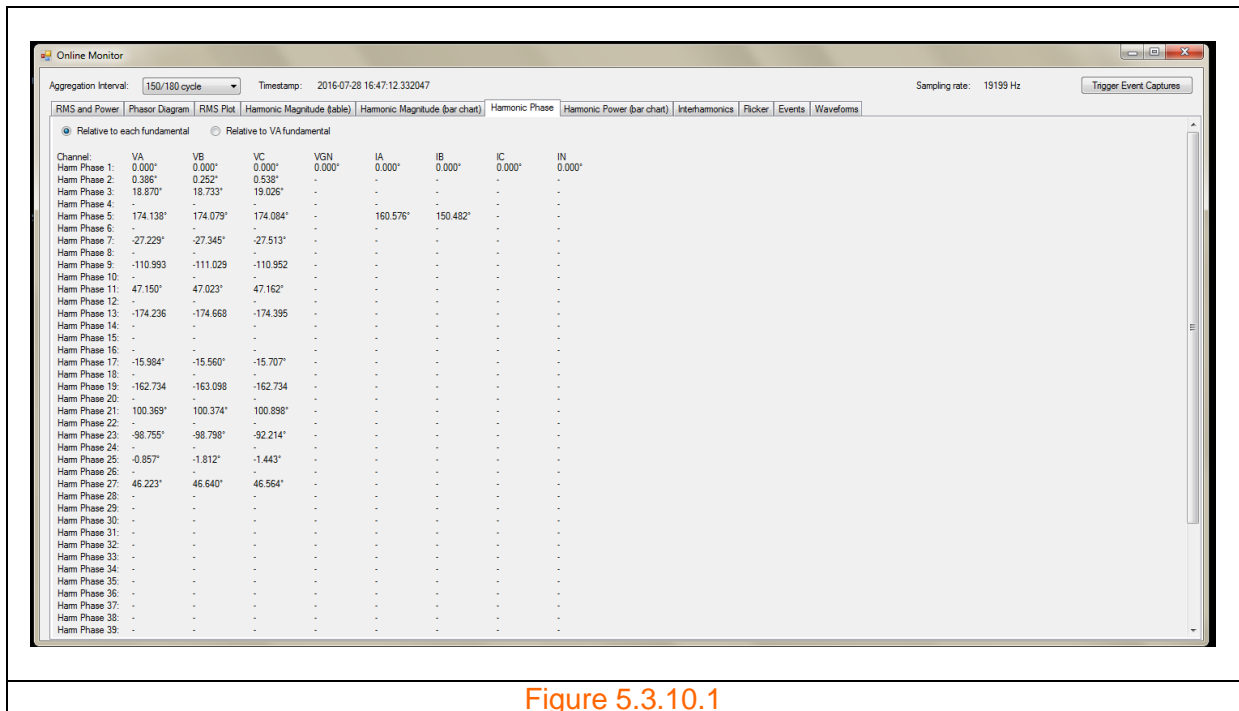

5.3.11 Harmonic power (bar chart)

The 'Harmonic Power (bar chart)' screen displays the live power or VA for each harmonic up to the 25th harmonic as shown in figure 5.3.11.1. No power will be displayed if no power measurement is available.

The user has the option to include the fundamental via a checkbox.

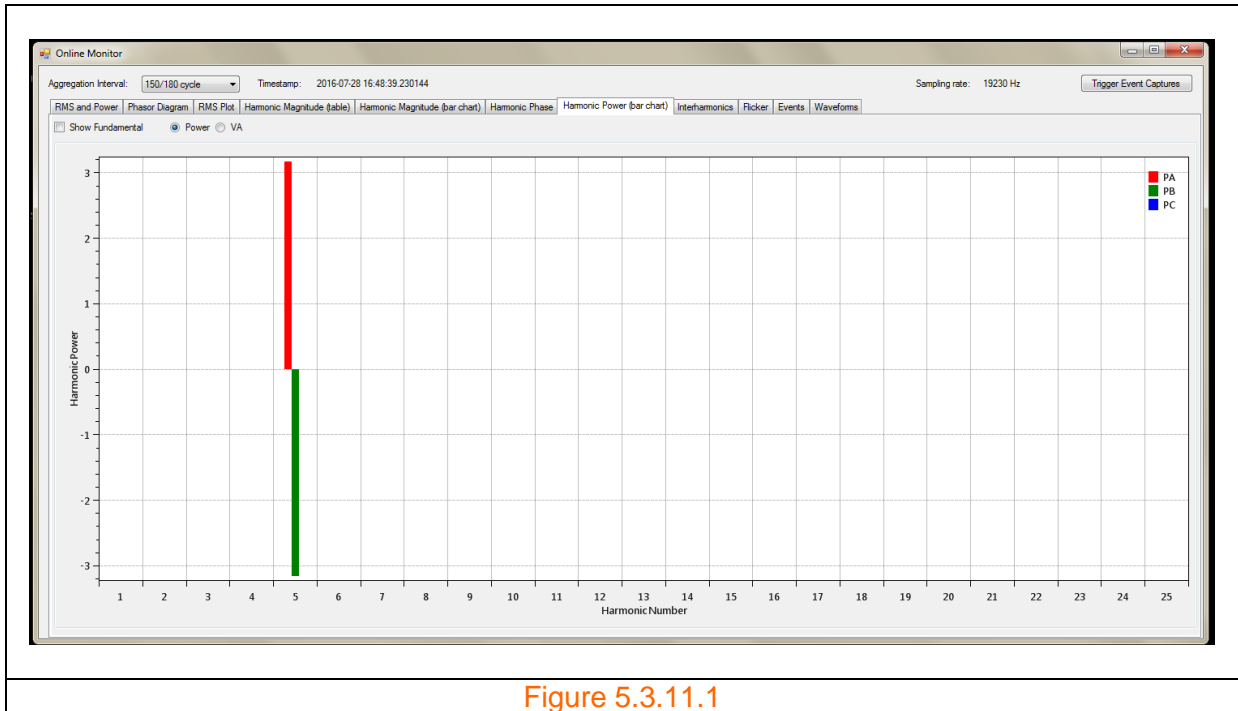

5.3.12 Interharmonics

The 'Interharmonics' screen displays the rms value for each voltage and current interharmonic up to and including the 50th interharmonic as shown in figure 5.3.12.1.

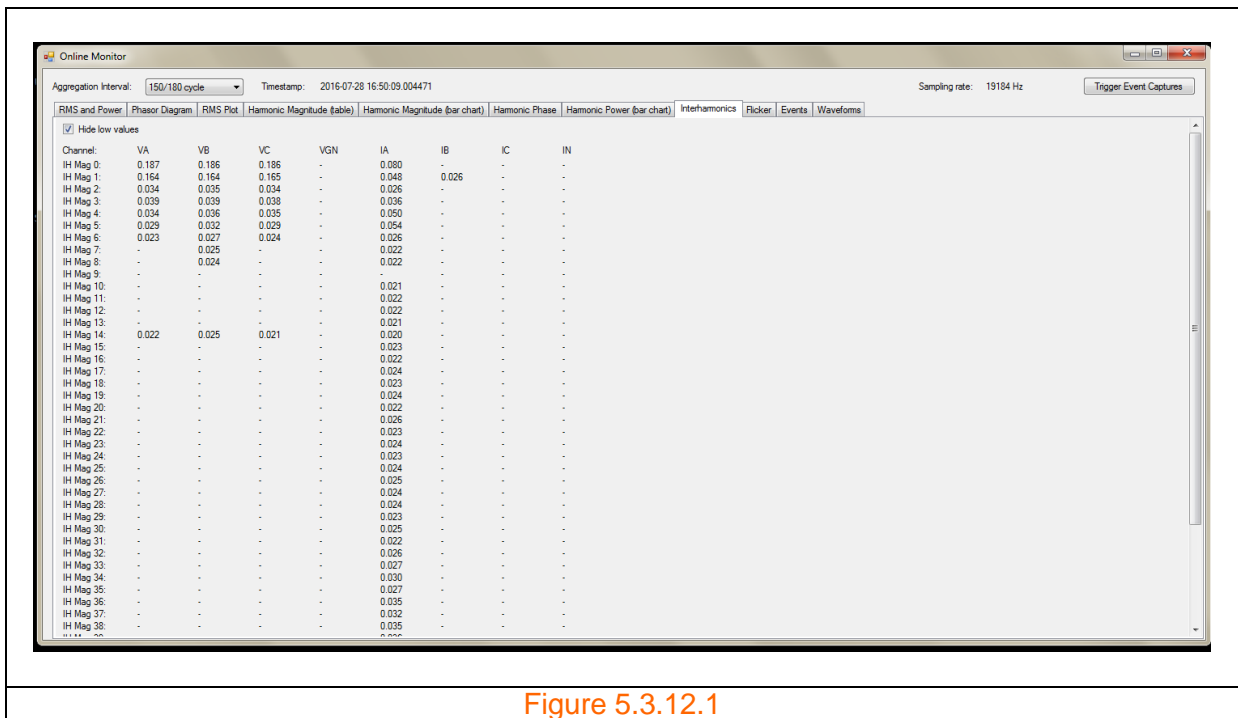

5.3.13 Flicker

The 'Flicker' screen displays the values of the flicker indices for each voltage channel as shown in figure 5.3.13.1.

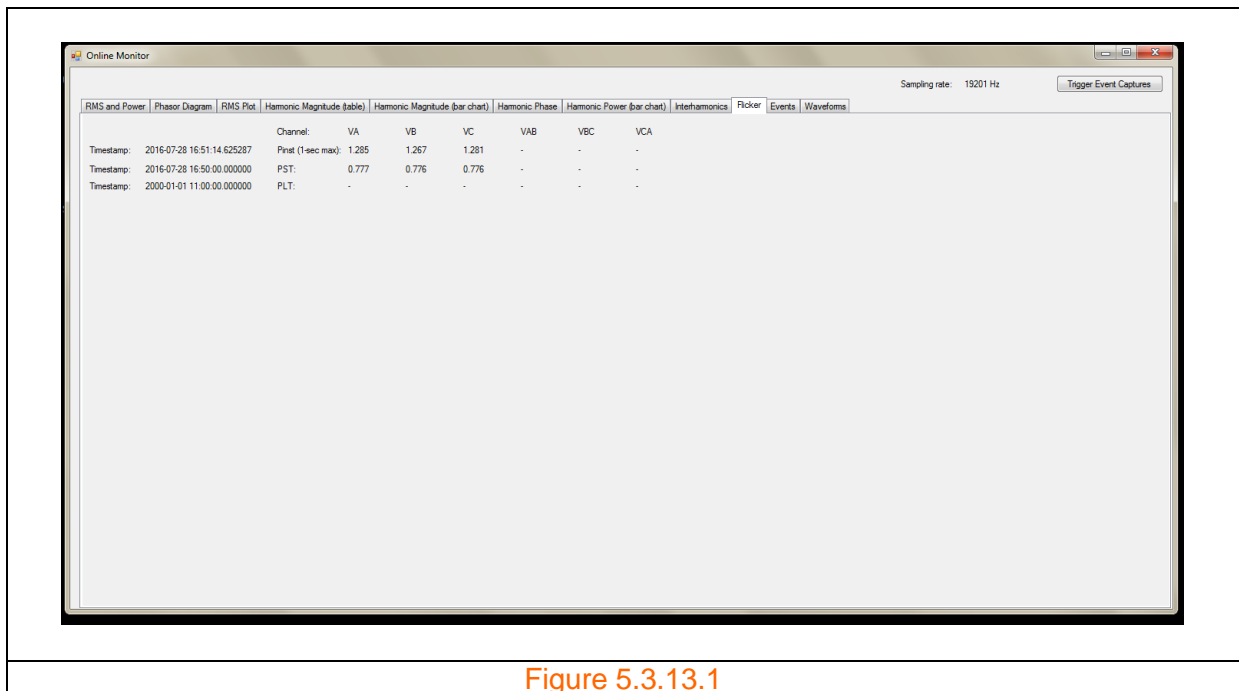

Figure 5.3.13.1

5.3.14 Events

The 'Events' screen displays event information.

5.3.14.1 No events

The screen shown in figure 5.3.14.1.1 shows no events.

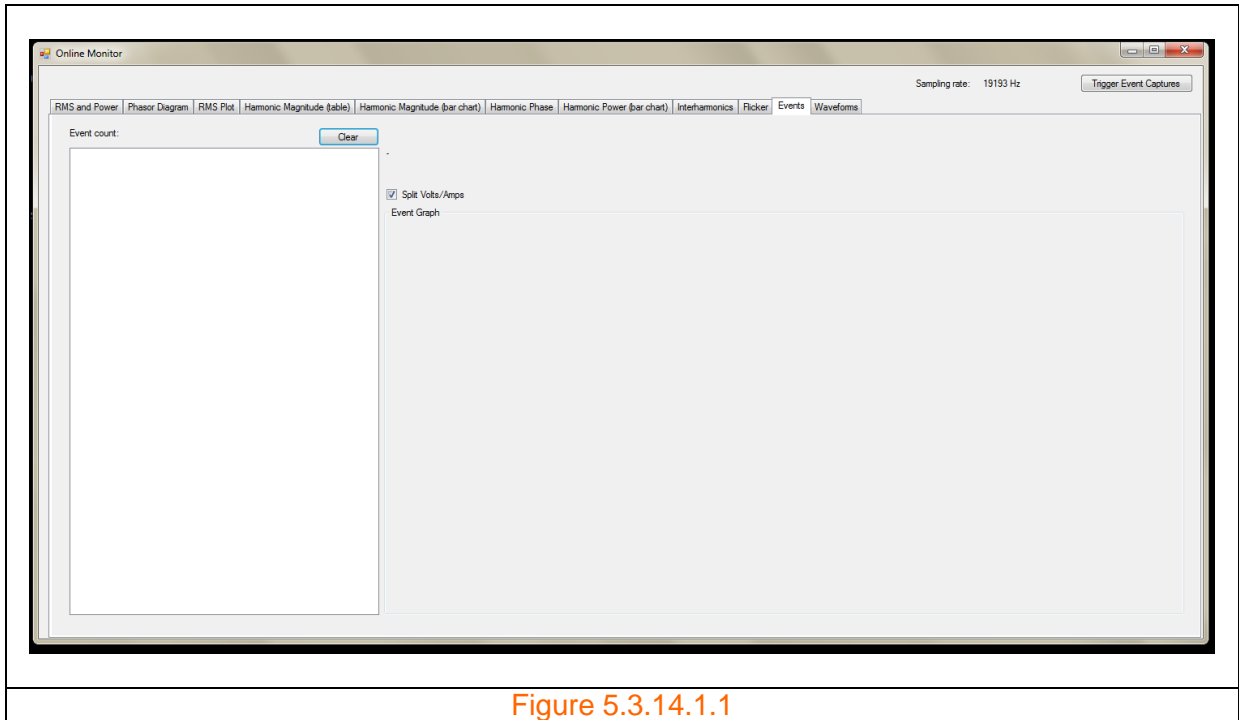

5.3.14.2 Listed events

Figure 5.3.14.2.1 shows a single event in the events list.

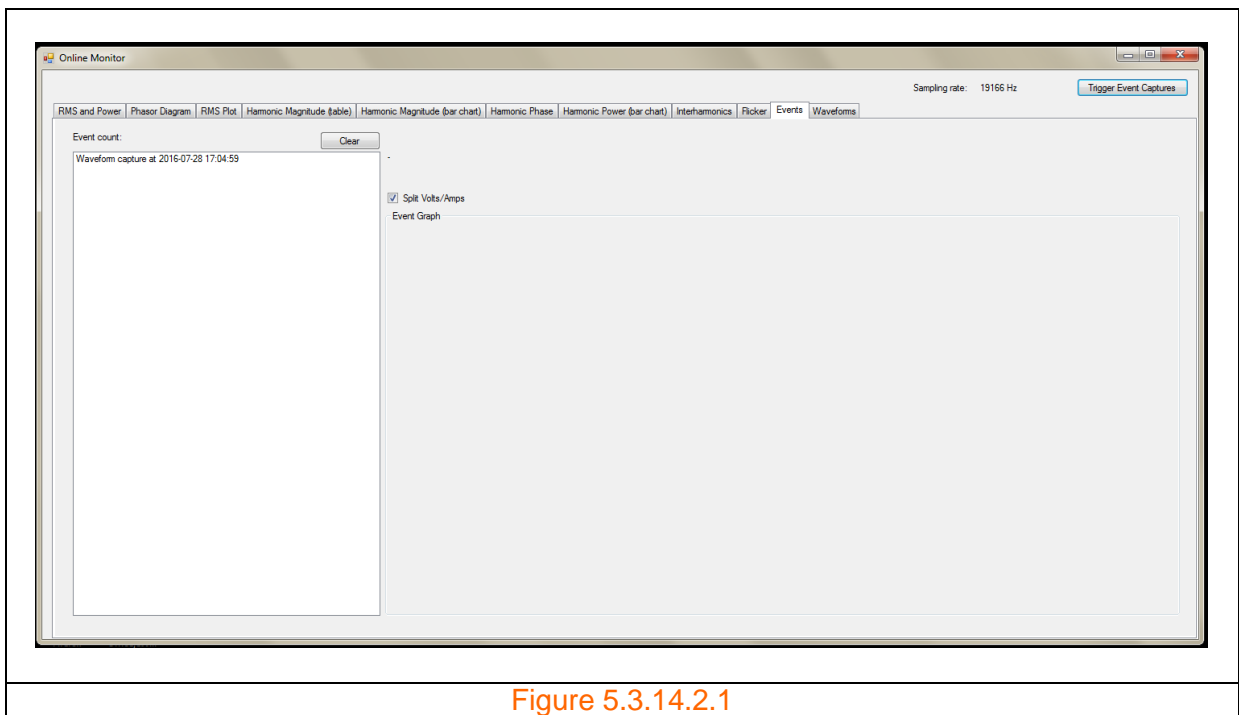

5.3.14.3 Event information

The screen shown in figure 5.3.14.3.1 shows two events, one RMS event and one waveform event. Clicking the first event in the list will: (a) highlight the selected event; (b) automatically generate a chart with waveforms; and (c) display details about the event above the chart.

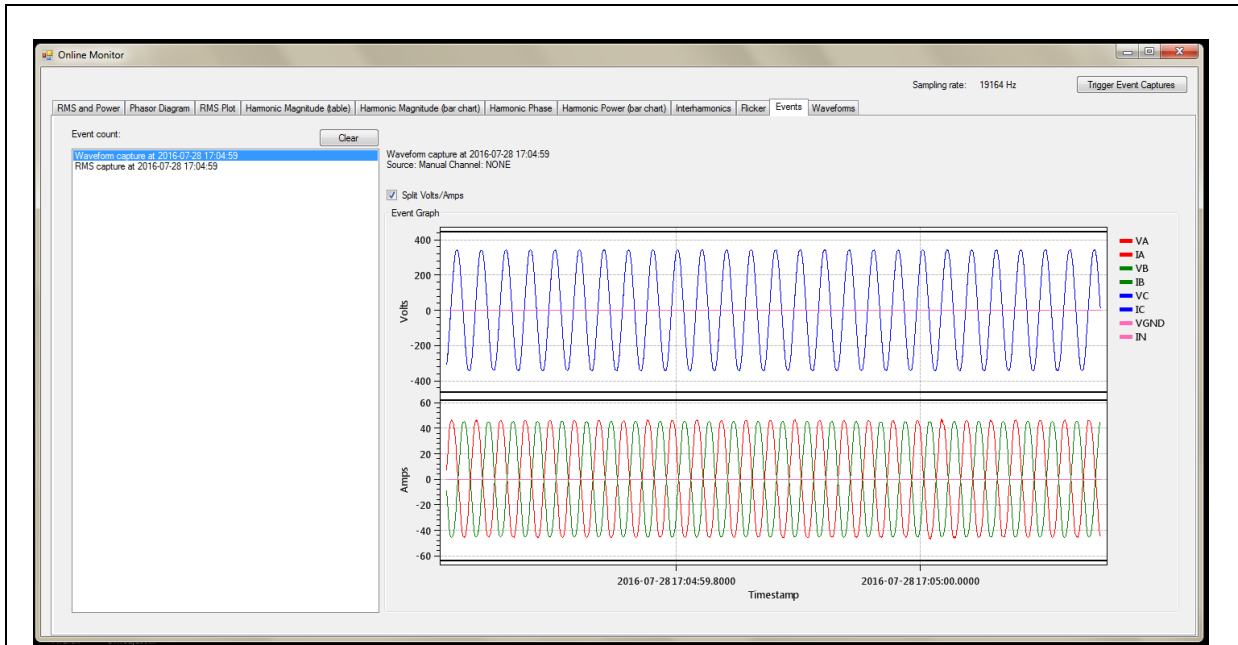

Figure 5.3.14.3.1

5.3.14.4 Trace selection

The user is able to remove or add any trace from the graph by clicking on the trace legend. The legend of deselected traces changes to a faint grey as shown in figure 5.3.14.4.1.

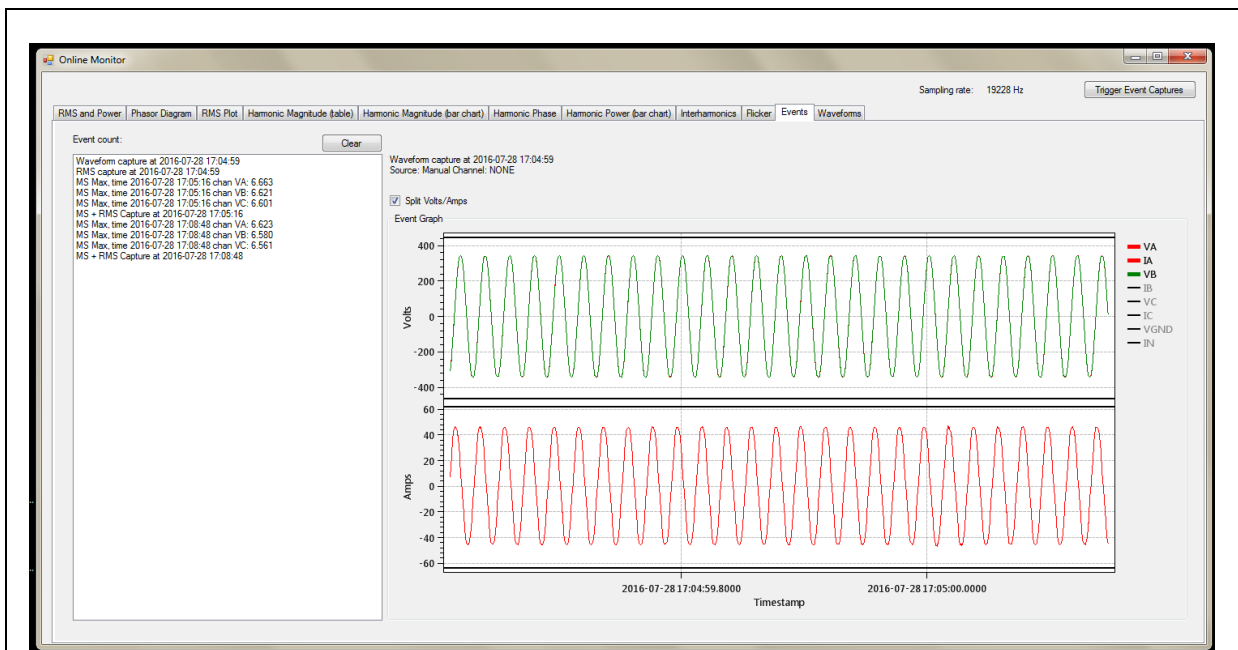
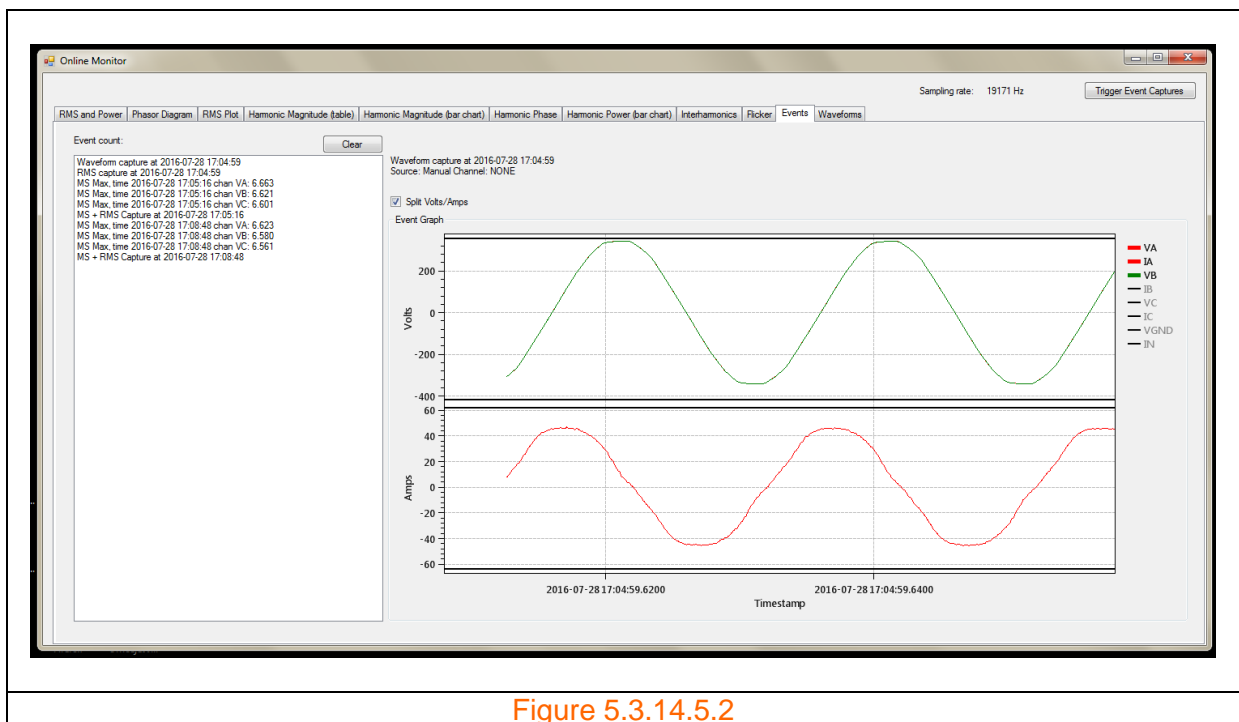
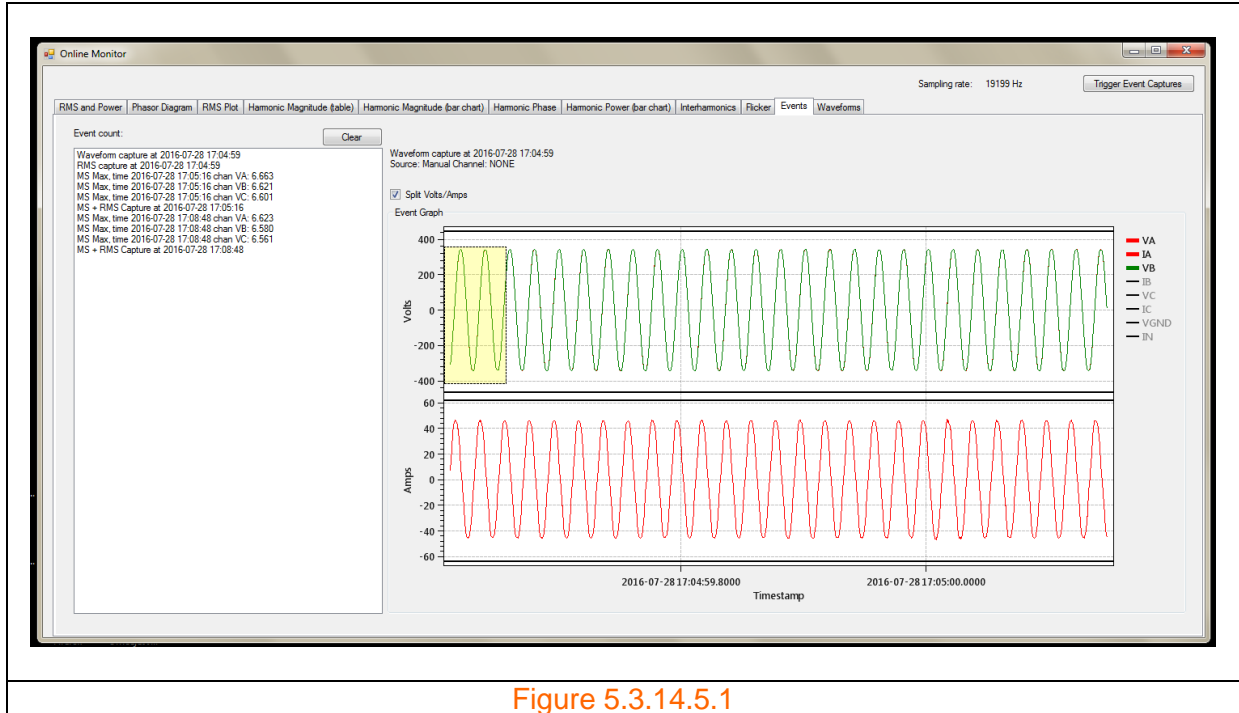

Figure 5.3.14.4.1

5.3.14.5 Zooming

The user is able to zoom into the waveform by selecting a portion by the application of a selection box. Selection box applied to figure 5.3.14.4.1 is shown in figure 5.3.14.5.1 with the result shown in figure 5.3.14.5.2.



5.3.14.6 Examples of RMS and Mains Signalling events

Further examples of RMS and Mains Signalling events are shown in figures 5.3.14.6.1 to 5.3.14.6.6 without and with zooming applied.

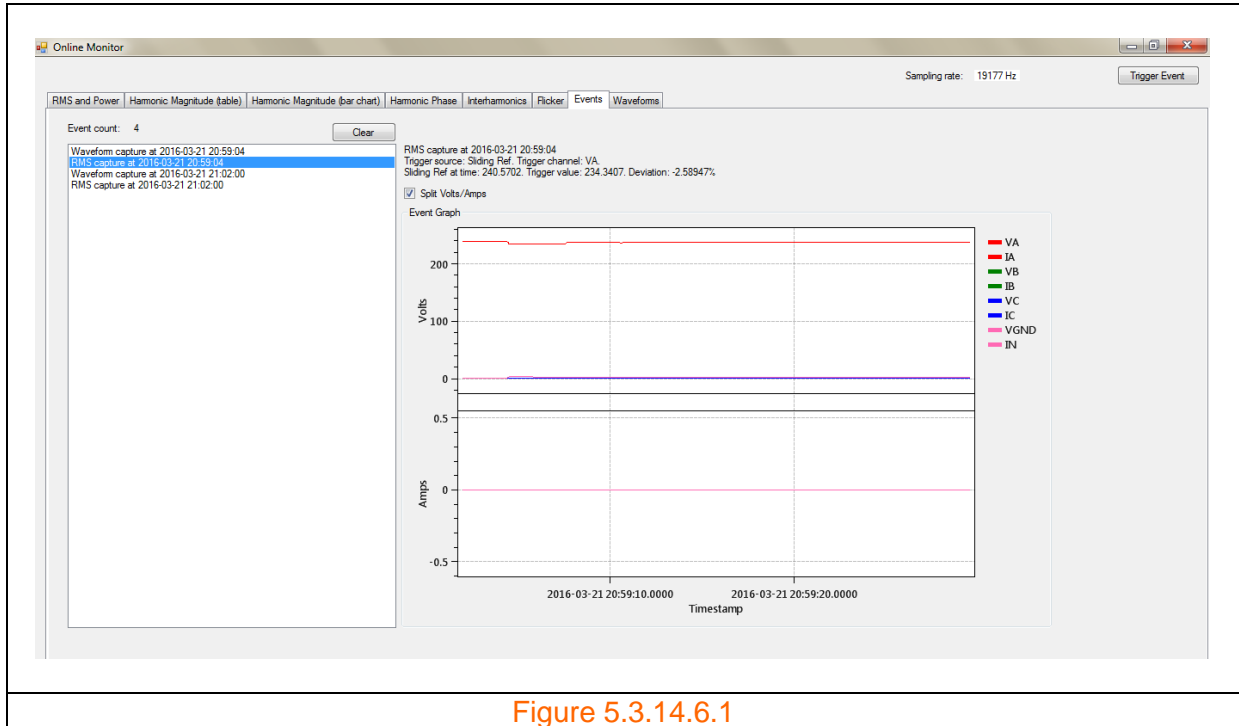

Figure 5.3.14.6.1

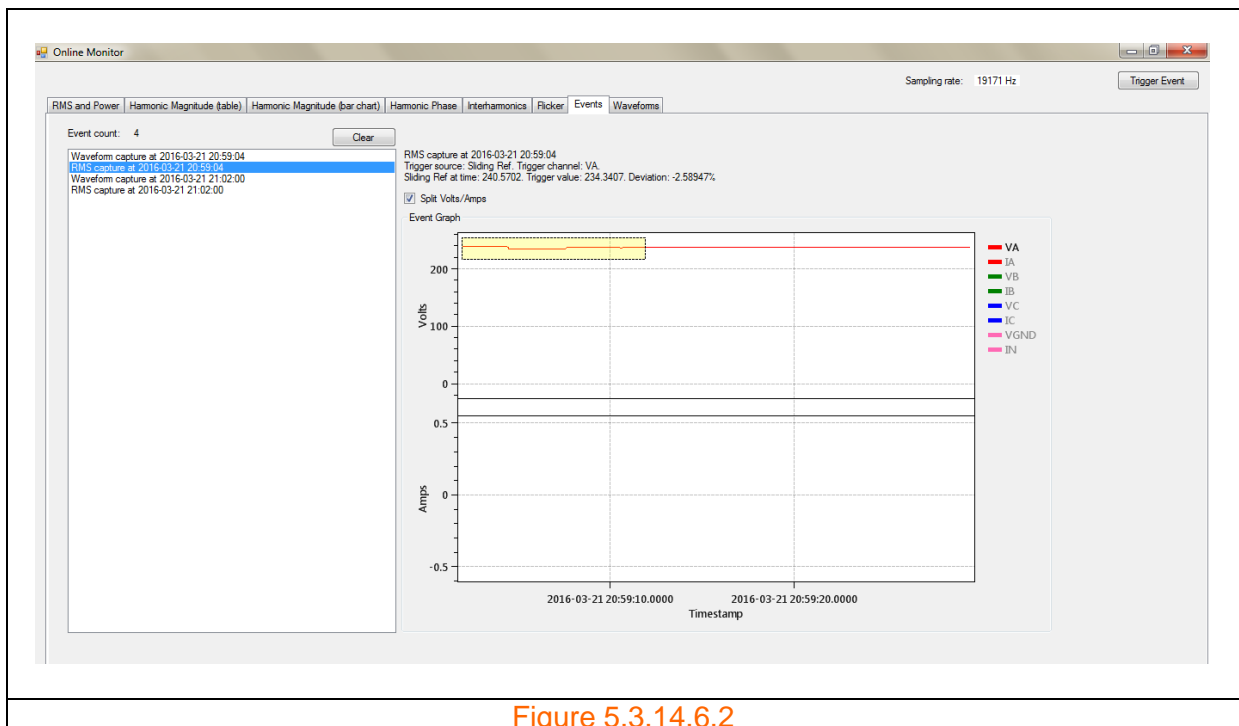

Figure 5.3.14.6.2

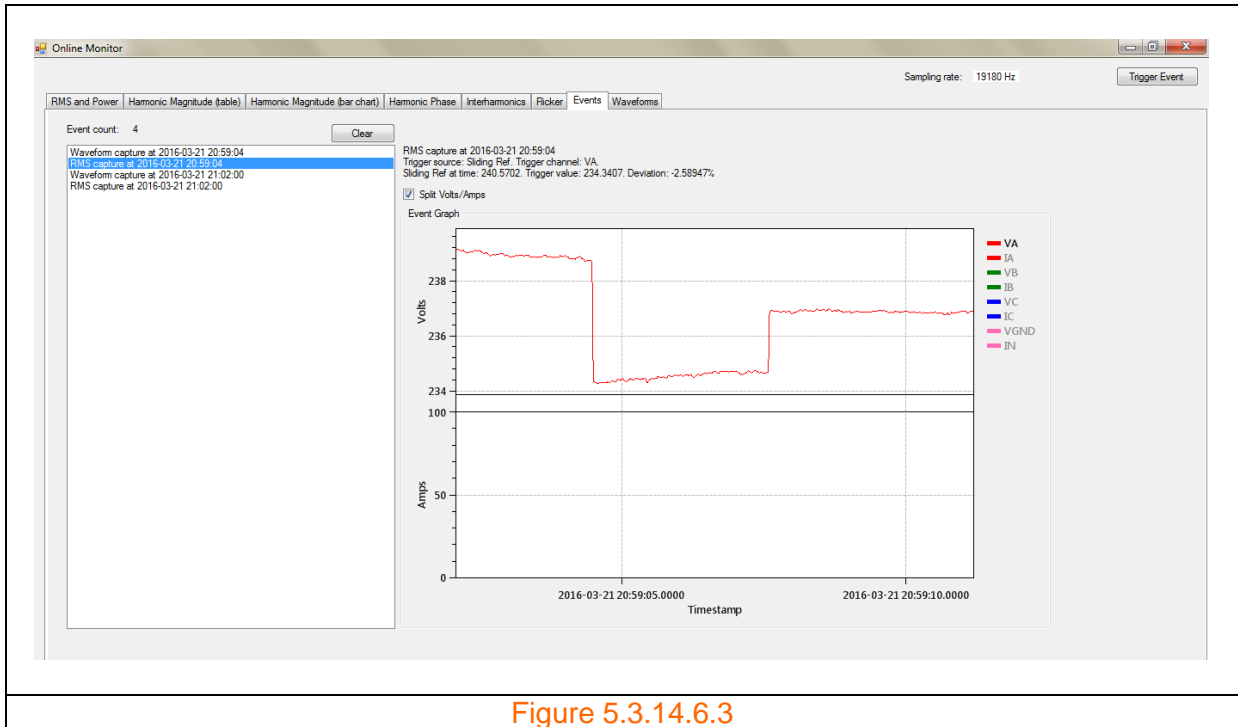

Figure 5.3.14.6.3

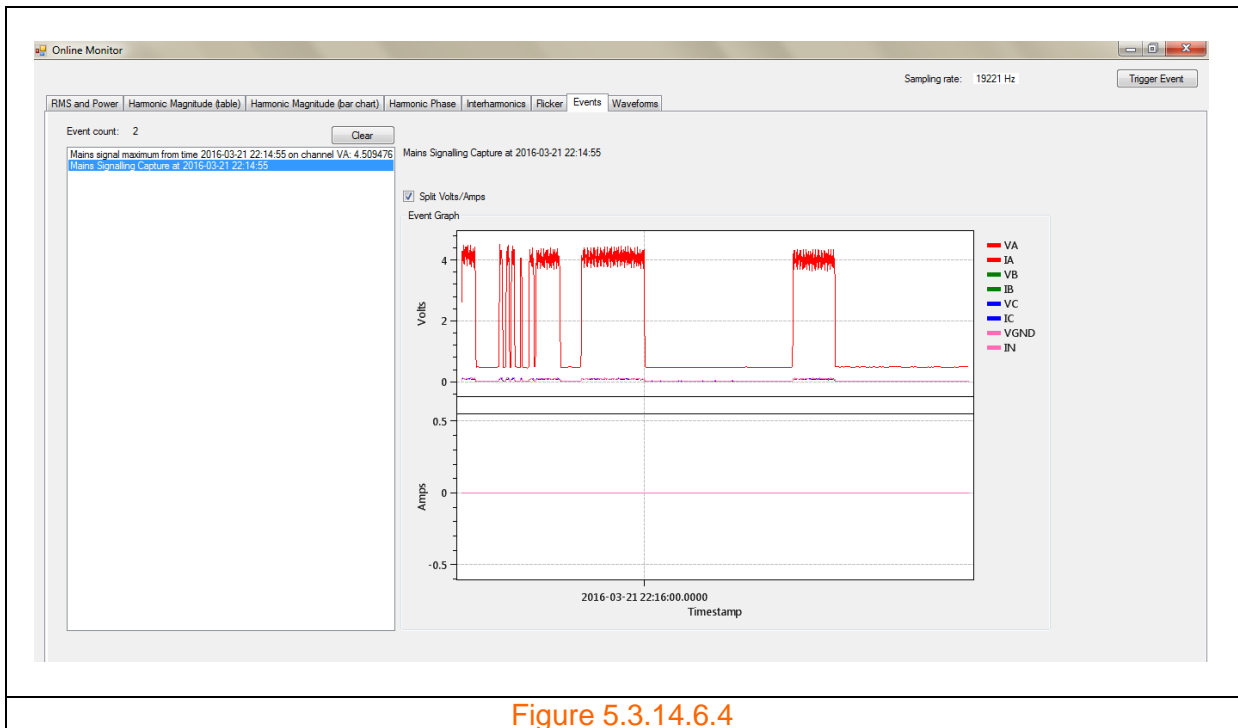

Figure 5.3.14.6.4

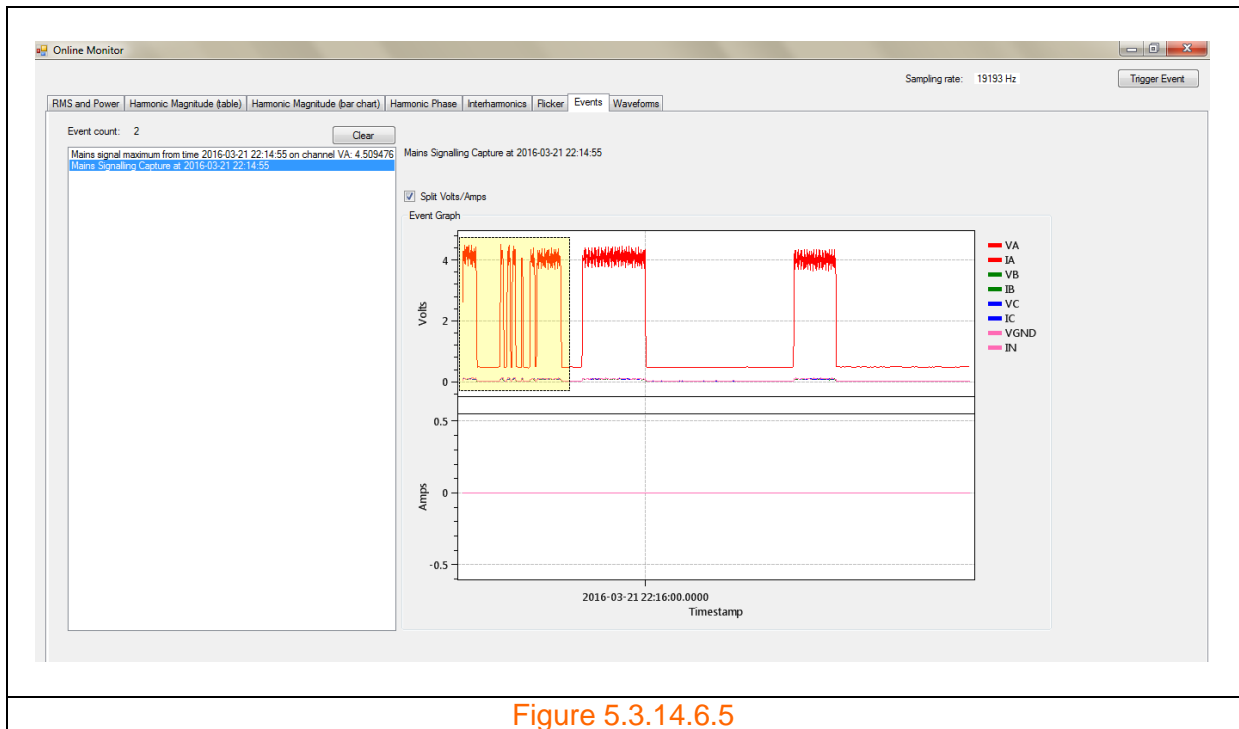

Figure 5.3.14.6.5

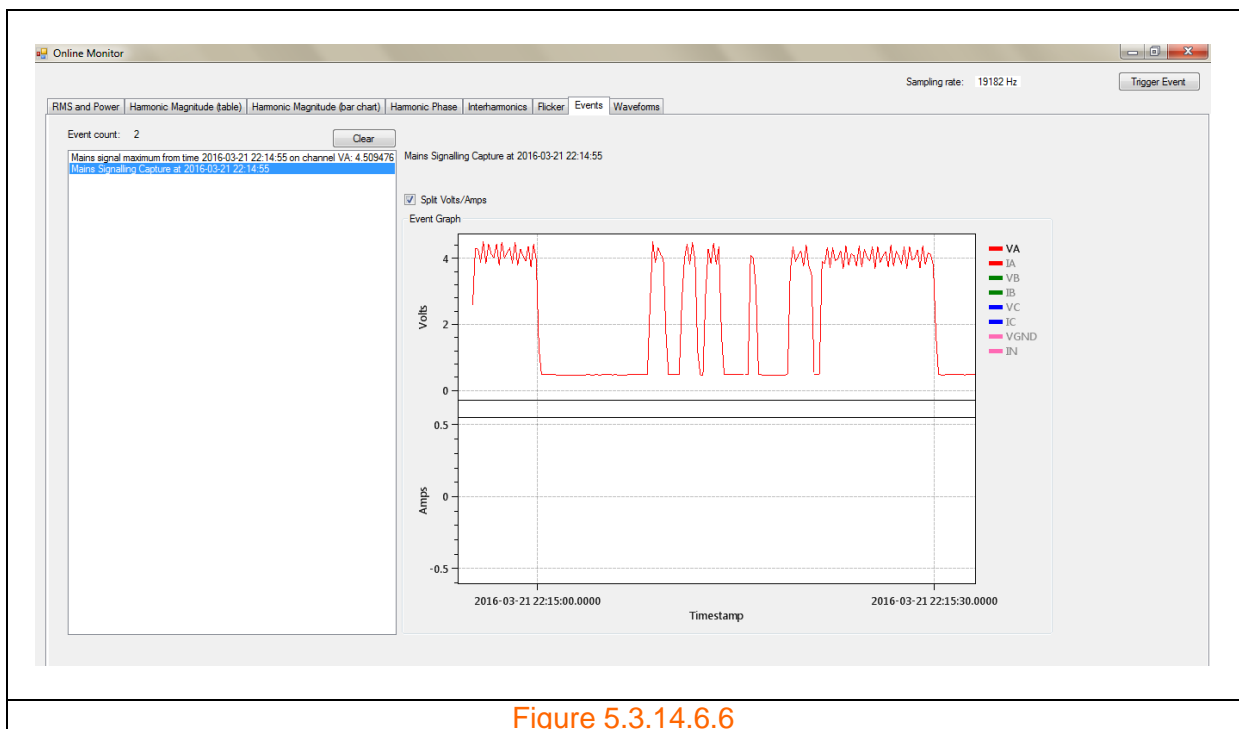
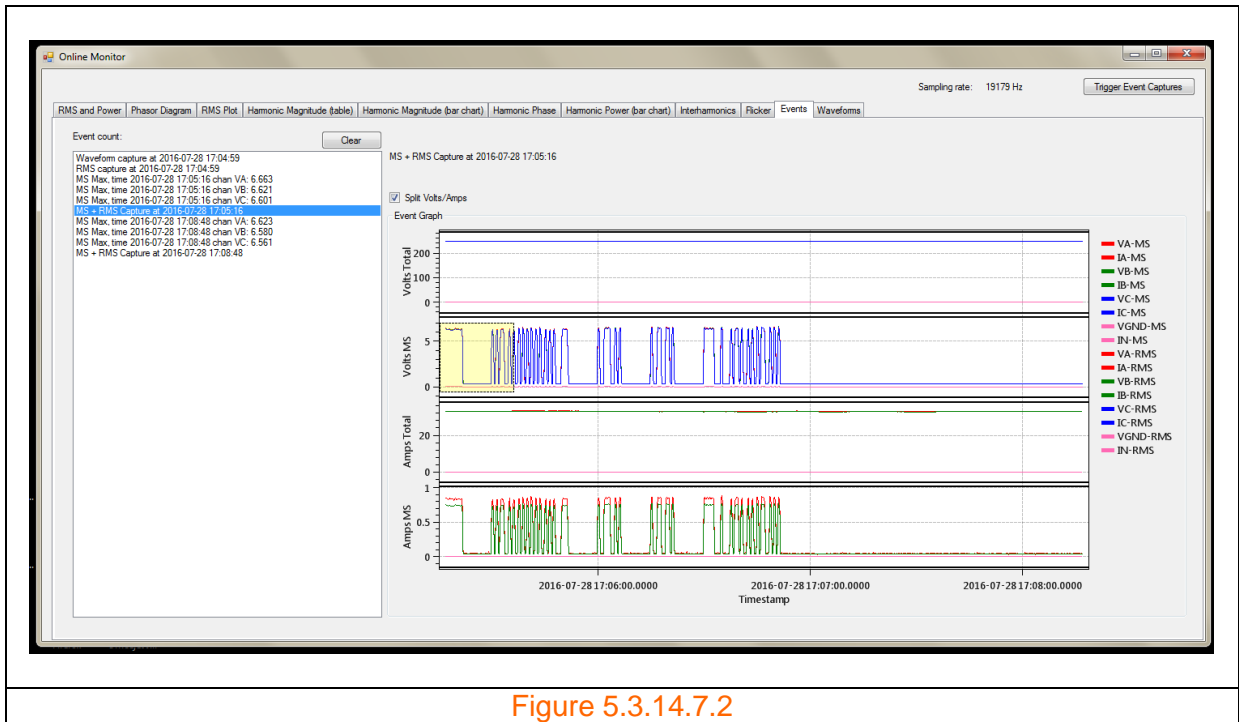
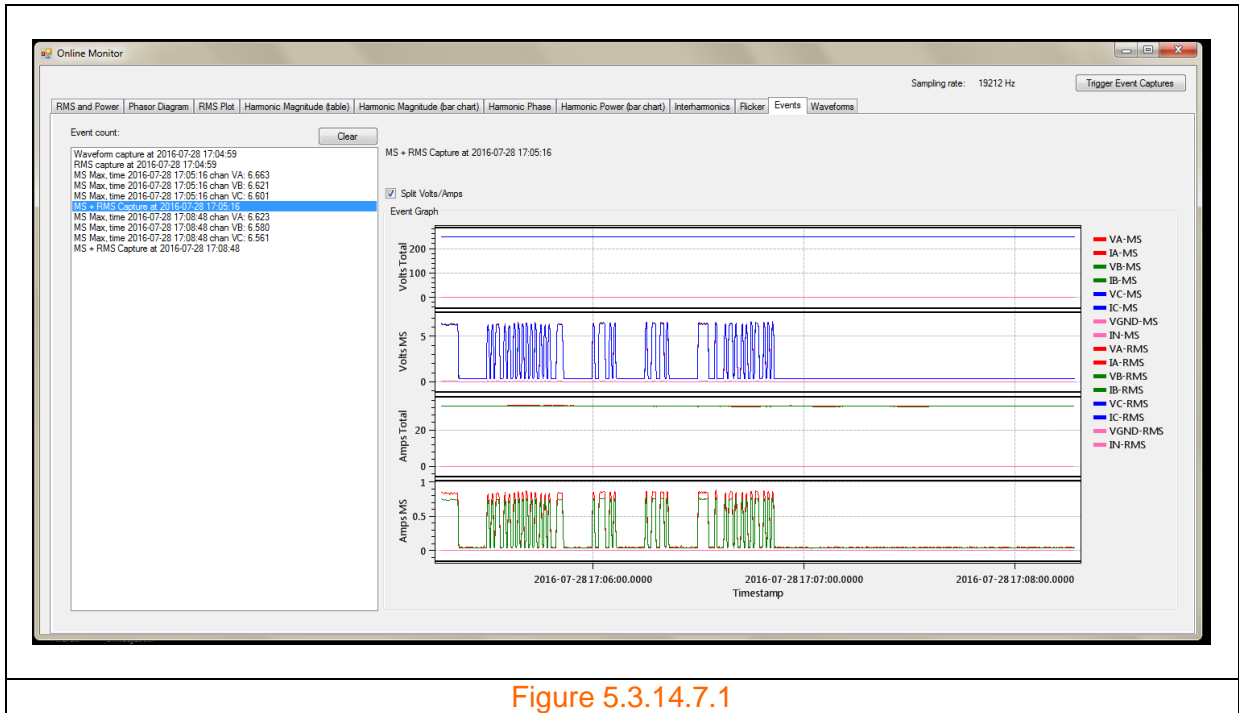

Figure 5.3.14.6.6

5.3.14.7 Examples of Coupled Mains Signalling + RMS events

Further examples of coupled Mains Signalling and RMS events are shown in figures 5.3.14.7.1 to 5.3.14.7.3 without and with zooming applied.



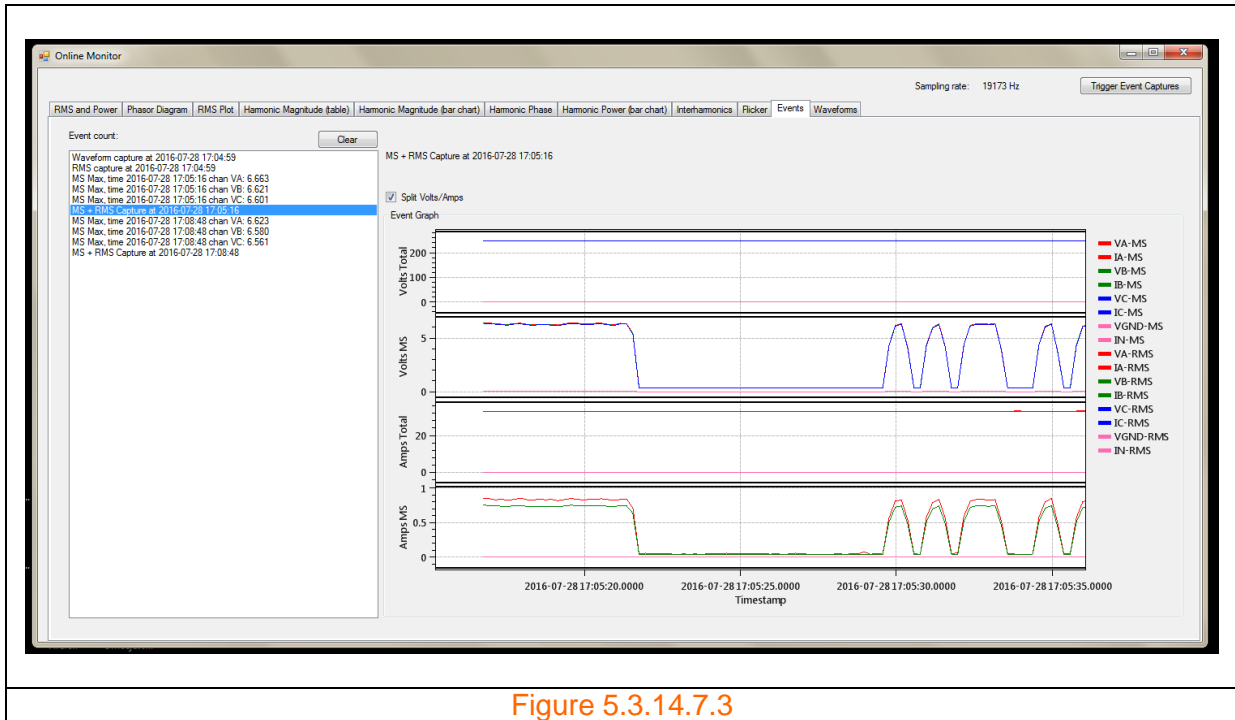

Figure 5.3.14.7.3

5.3.14.8 Combining charts

The user is able to combine the 'Volts and Amps' view into a single chart by deselecting the 'Split Volts/Amps' check box and then again selecting the desired event.

Figure 5.3.14.81.1 shows the combined charts of that of figure 5.3.14.7.3.

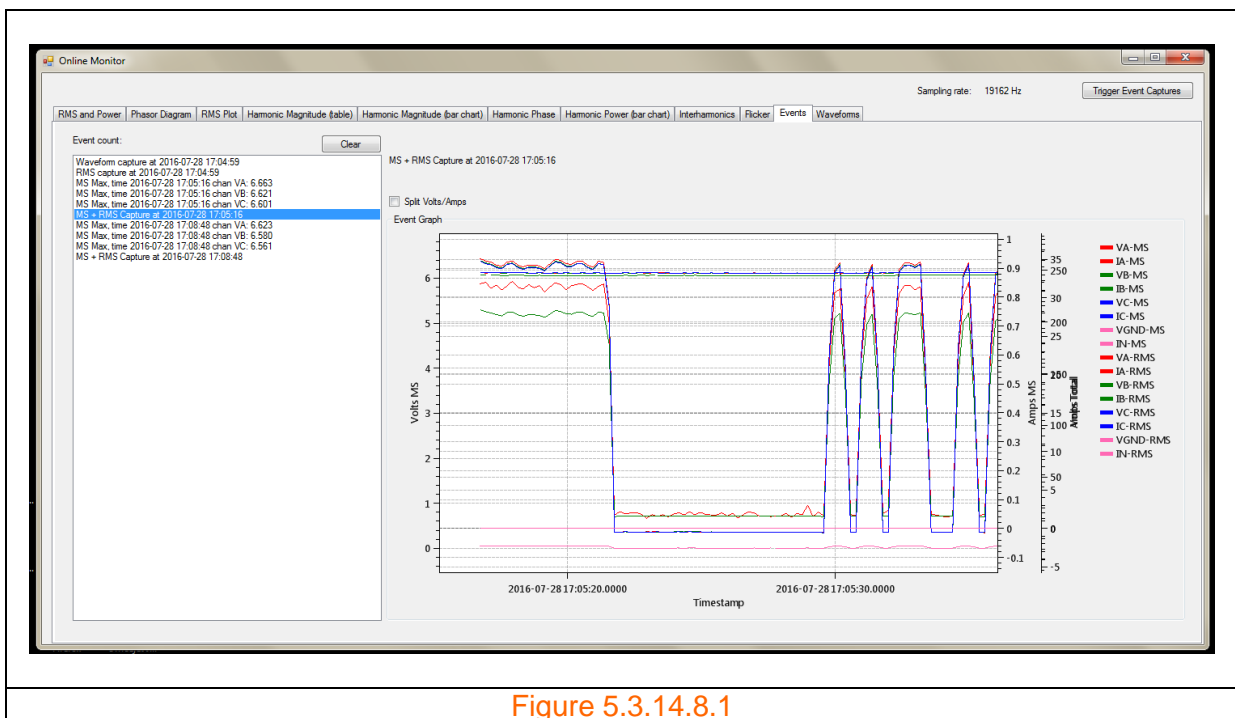
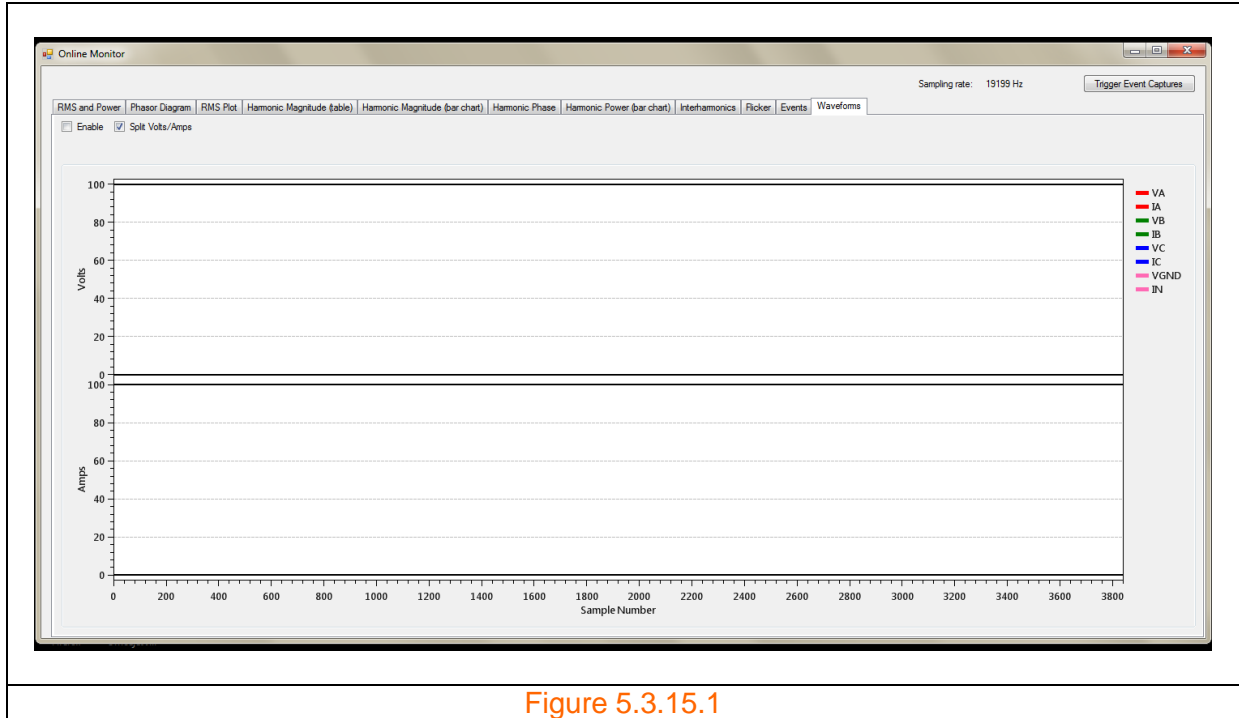

Figure 5.3.14.8.1

5.3.15 Waveforms

The 'Waveforms' screen displays the 10/12 waveforms of all voltage and current channels, but is initially disabled as shown in figure 5.3.15.1. Update rate may be less often than every 10/12 cycles due to the volume of data transfer.



Select the 'Enable' checkbox to view channels as shown in figure 5.3.15.2.

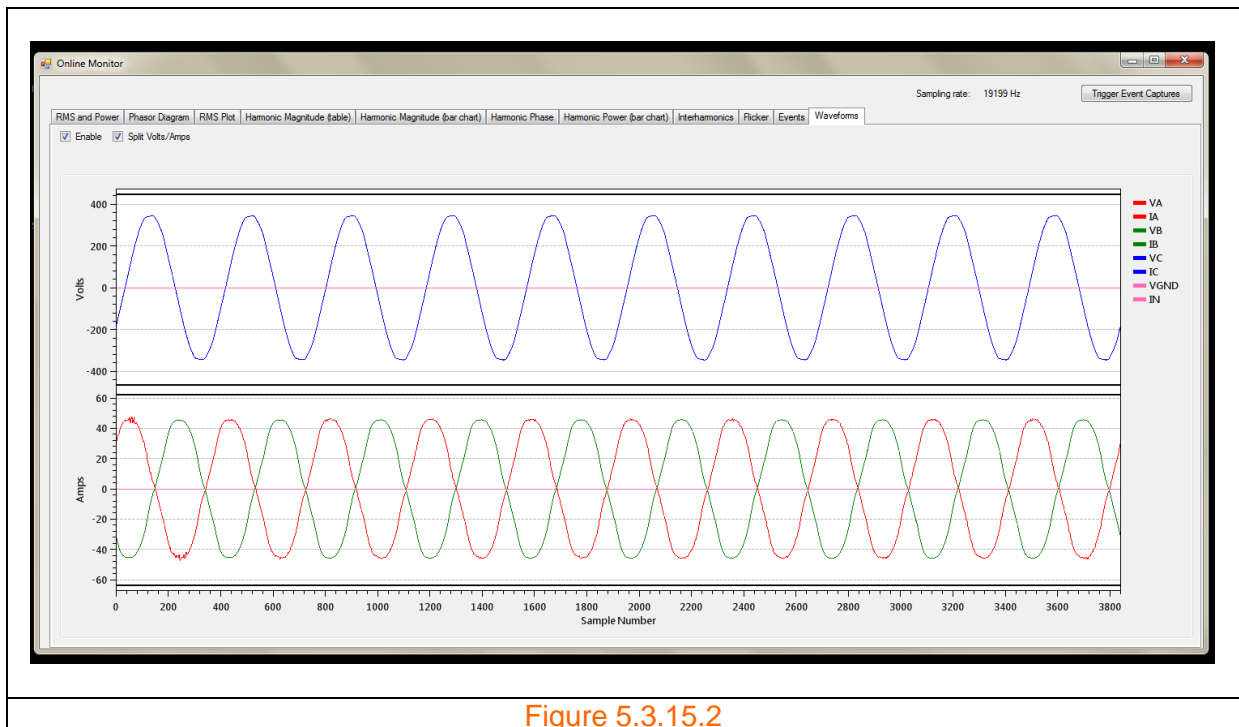

The user is able to combine the 'Volts and Amps' view into a single chart by deselecting the 'Split Volts/Amps' check box. The new view is shown in figure 5.3.15.3.

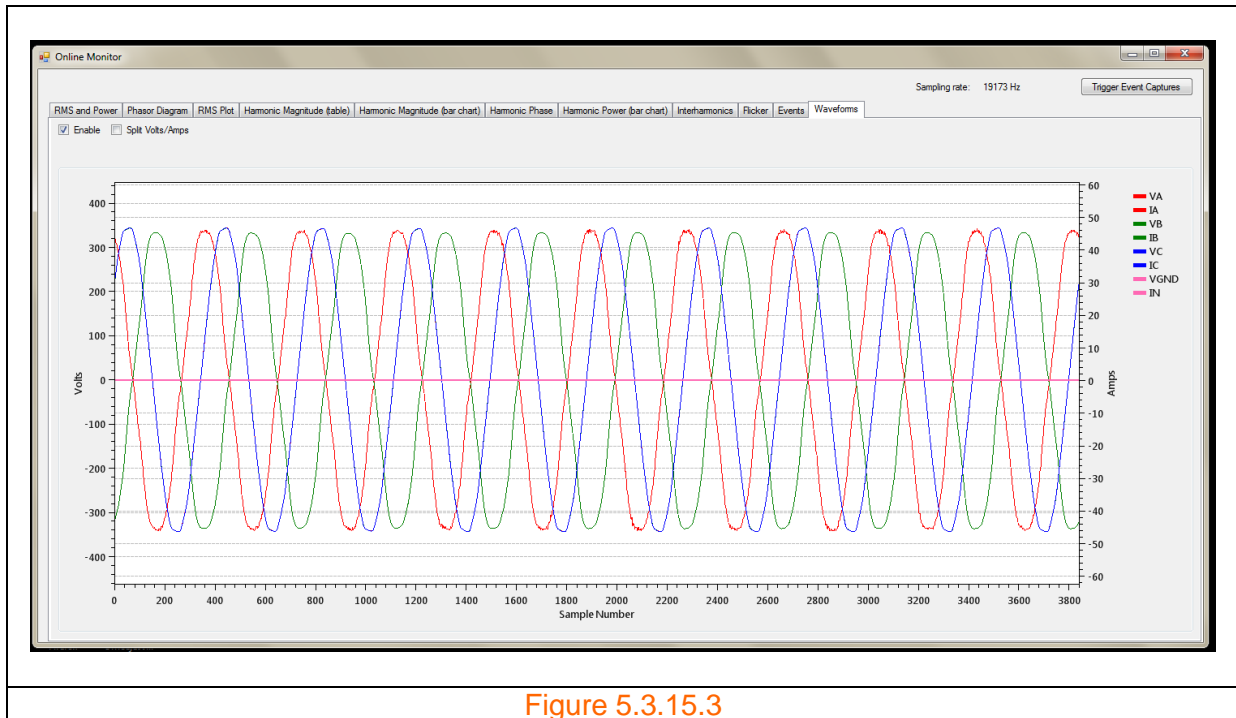

5.4 Configuration

Clicking on the 'Configuration' button in figure 5.4.1 opens the 'Miro configuration' window shown in figure 5.4.2.

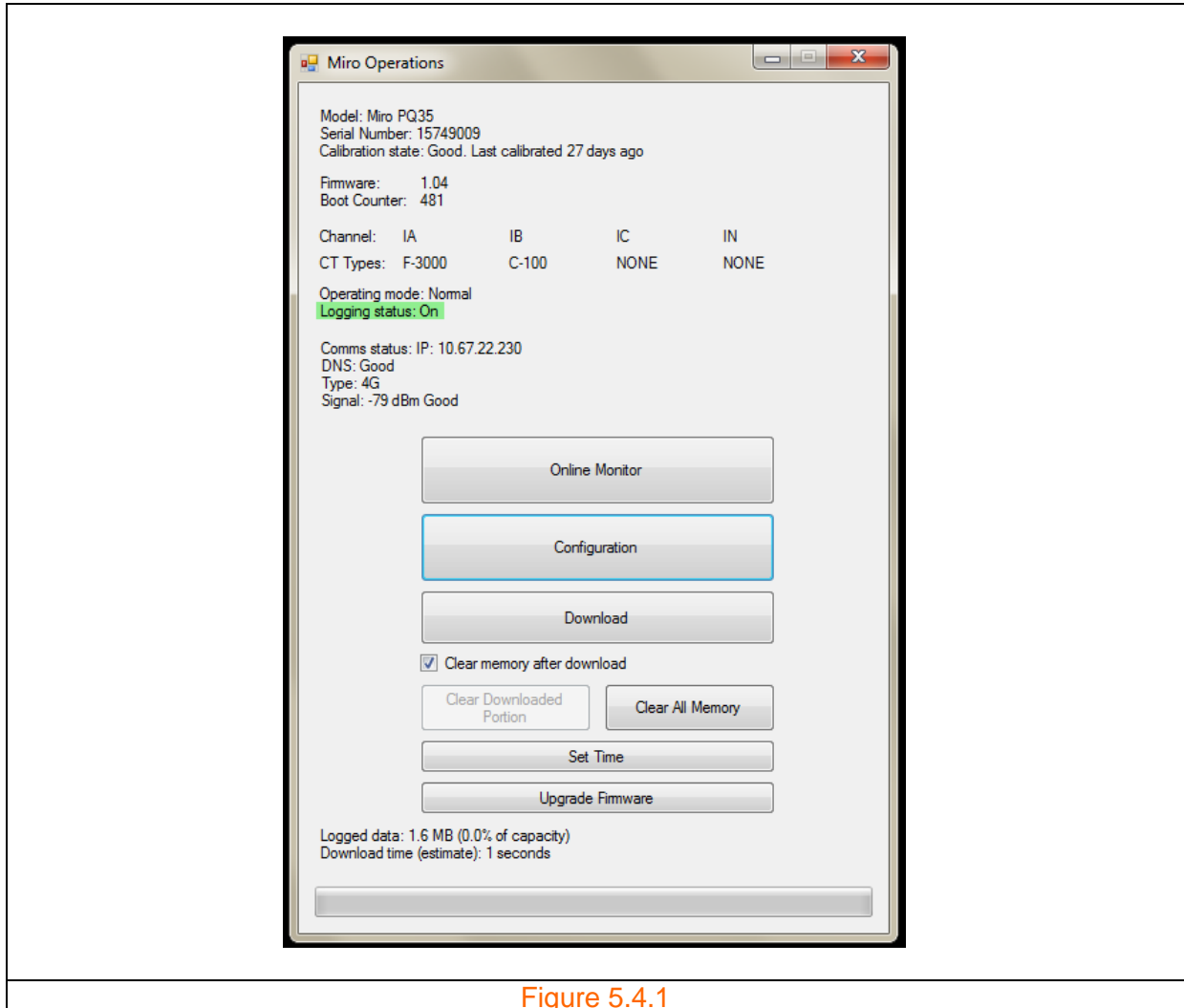

Figure 5.4.1

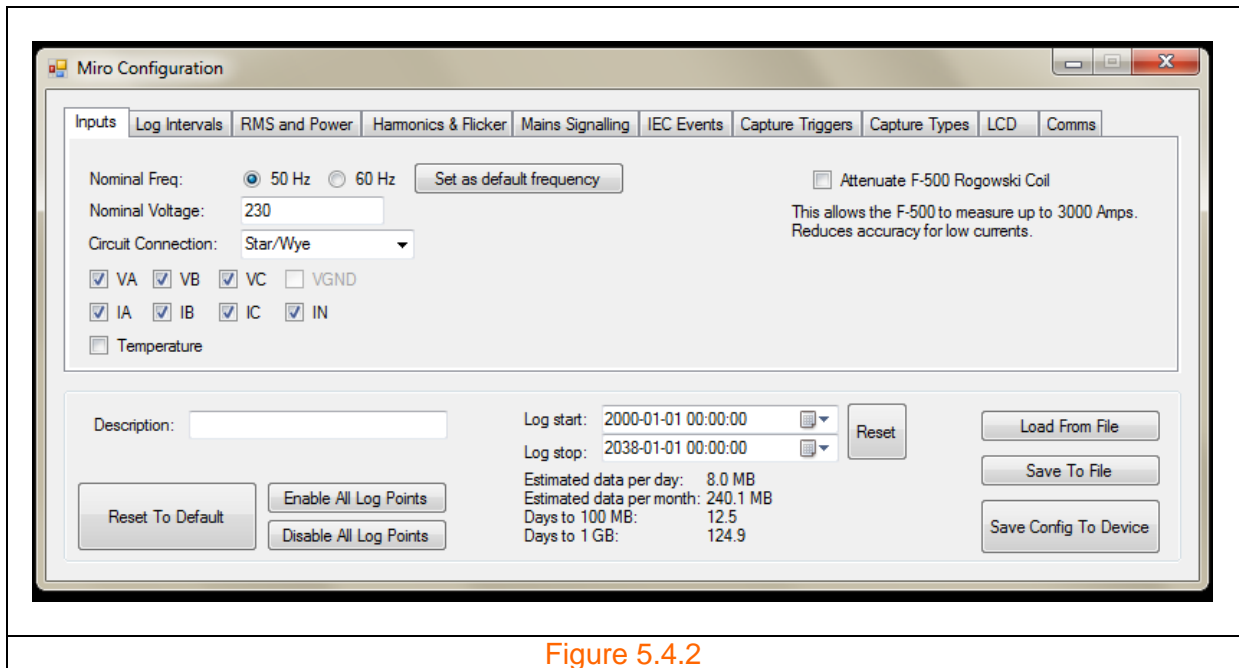

Figure 5.4.2

5.4.1 General

General configuration options are shown in figure 5.4.1.1 and located below the tabs.

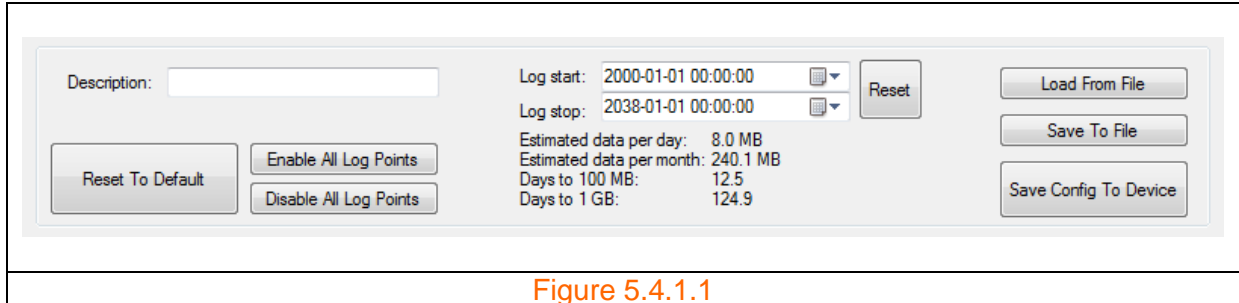

Figure 5.4.1.1

5.4.1.1 Configuration description

An option is provided to enter a description of the configuration. In this case the configuration is blank.

5.4.1.2 Reset to default

Clicking the 'Reset To Default' button sets the configuration to factory settings.

5.4.1.3 Enable and disable log points

Clicking the 'Enable All Log Points' button ensures all parameters are logged. Clicking the 'Disable All Log Points' button unchecks all parameters. It serves as an efficient way to set a single log parameter without having to physically uncheck every parameter in the configuration tabs.

5.4.1.4 Log start and stop date-times

The user input 'Log start' and 'Log stop' date times allows the user to control the log period. Clicking the 'Reset' button presets the date times to factory settings.

5.4.1.5 Log memory usage

The log memory usage depends upon the particular configuration. Useful memory usage metrics are displayed on the configuration window and include:

- (a) Estimated data per day;
- (b) Estimated data per month;
- (c) Days to 100MB; and
- (d) Days to 1GB.

5.4.1.6 Load from and save to file

The 'Load From File' button allows a predefined configuration to be loaded. The 'Save To File' button allows the current configuration to be saved to a filename.

5.4.1.7 Save configuration to device

The 'Save Config To Device' button loads the configuration to the Miro. Configuration will be loaded and active immediately. There is no need to stop logging or clear memory.

5.4.2 Inputs

The 'Inputs' tab provides all physical input channels to be monitored and is active upon clicking the 'Configuration' button as shown in figure 5.4.2 and figure 5.4.2.1.

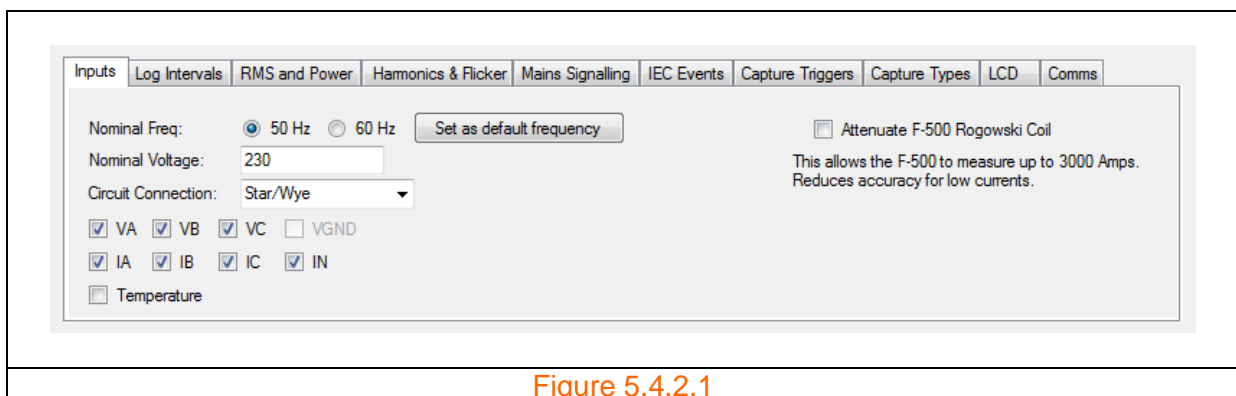

5.4.2.1 Nominal frequency

The user can select between two standard power frequencies, 50Hz or 60Hz. The user also has the ability to set the selection as the default frequency.

As shown in figure 5.4.2.1.1 a message box appears when the user clicks the 'Set as default frequency' button confirming that the default frequency has been set. Click 'OK' to close the message box.

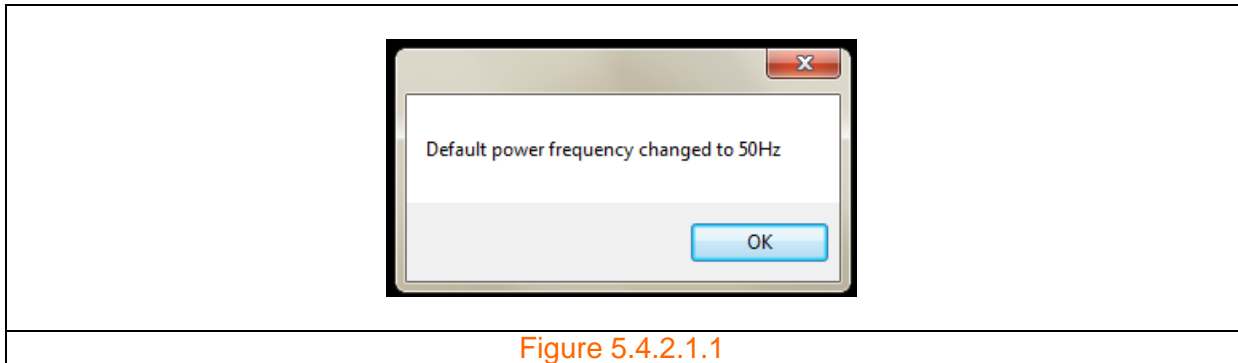

5.4.2.2 Nominal voltage

The user input '**Nominal Voltage**' is the voltage the Miro expects to measure across its voltage channel.

5.4.2.3 Circuit connection

As shown in figure 5.4.2.3.1 the user selectable '**Circuit Connection**' drop down list box provides various connections supported by the Miro. These include '**Star/Wye**', '**Delta**' and '**Single**'.

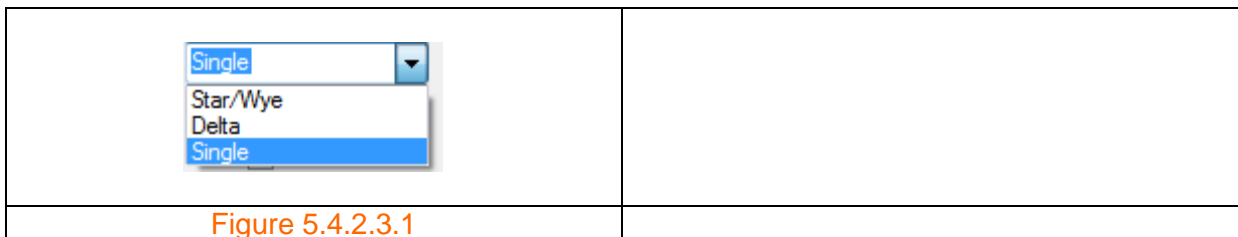

5.4.2.4 Channels

The voltage (VA, VB, VC and VGND*) and current (IA, IB, IC and IN) channels can be selected individually. The two temperature channels T1 and T2 are grouped together and selected when the '**Temperature**' checkbox is ticked.

Note that for event capture purposes, all channels are always captured. These settings only affect log parameters such as RMS magnitude.

*PQ45 only. Option always present as configuration is shared between models.

5.4.2.5 High sensitivity coil

The F-500 is a high sensitivity Rogowski coil, purposely designed to measure currents with upper limits of 500A or 3000A depending upon the setting of the '**Attenuate F-500 Rogowski Coil**' check box shown in figures 5.4.2.5.1 and 5.4.2.5.2.

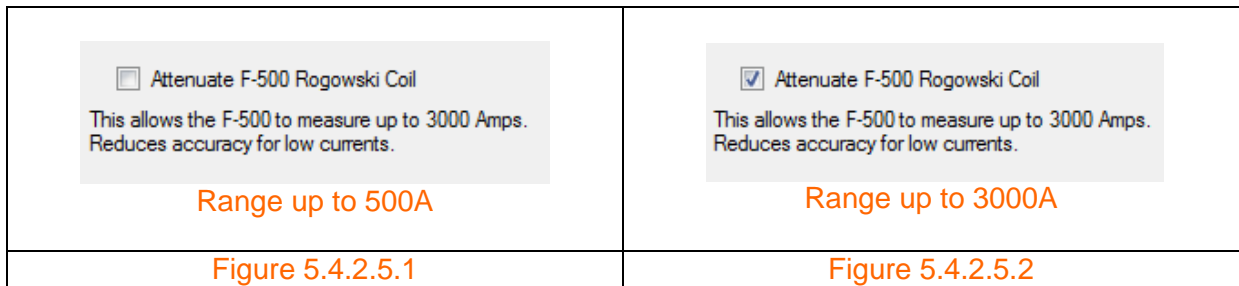

5.4.3 Log intervals

Clicking on the 'Log Intervals' tab opens a menu as shown in figure 5.4.3.1 that provides for concurrent logging at multiple intervals.

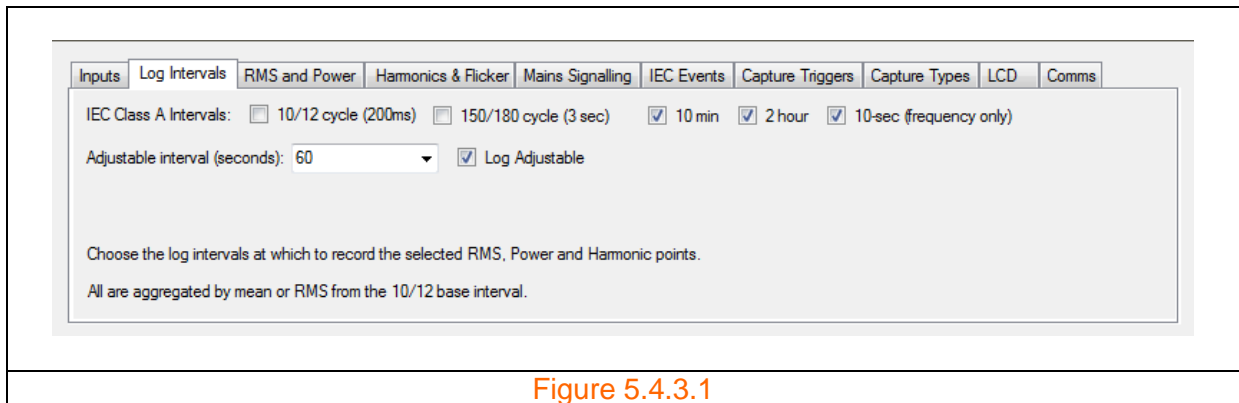

Figure 5.4.3.1

Selectable log intervals include: 10/12 cycle (50Hz / 60Hz); 150/180 cycle (50Hz / 60Hz); 10 minute; 2 hours; 10 sec. (frequency only); and Adjustable.

The 'Adjustable interval' is settable from 1 second to 3600 seconds. The user is able to click in the cell and alter the value or click on the arrow to expand the drop down box as shown in figure 5.4.3.2 which provides suggested values.

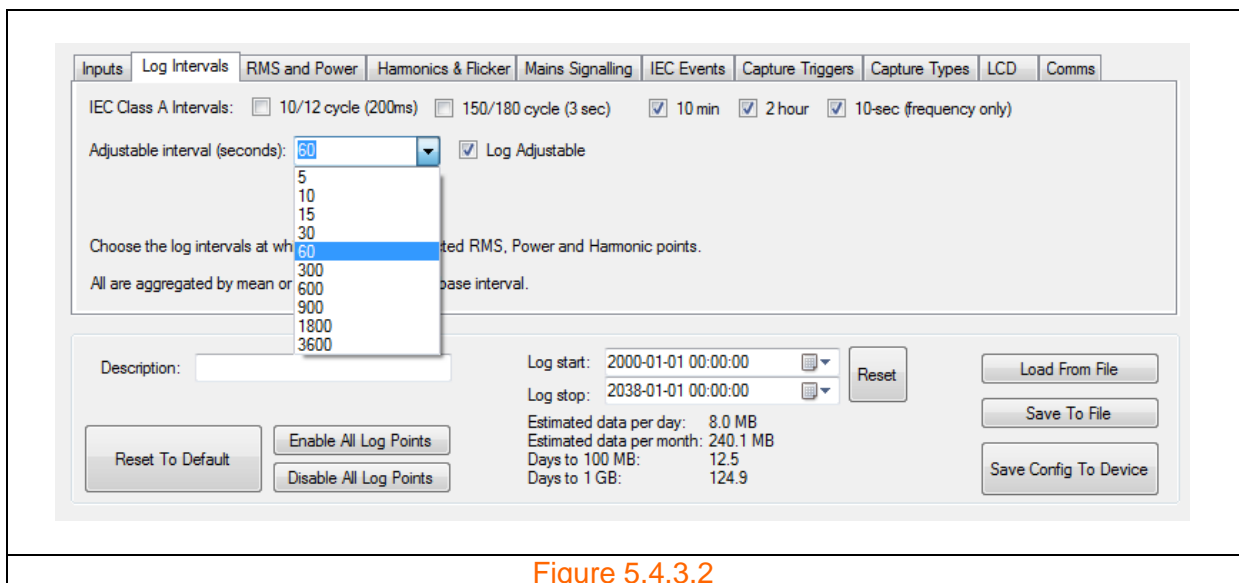

Figure 5.4.3.2

The default adjustable log interval is set to 60 seconds.

If the 10/12 cycle log interval is selected:

1. The '10/12 cycle (200ms)' text is highlighted with a red background as shown in figure 5.4.3.3;
2. A message box appears as shown in figure 5.4.3.4 warning the user of the additional significant daily memory usage; and
3. A warning message appears on the 'Miro Operations' window (as shown in figure 5.4.3.5) alerting the user that this selection will consume memory. As shown in figure 5.4.3.6, the message is removed when the 10/12 cycle log interval is deselected.

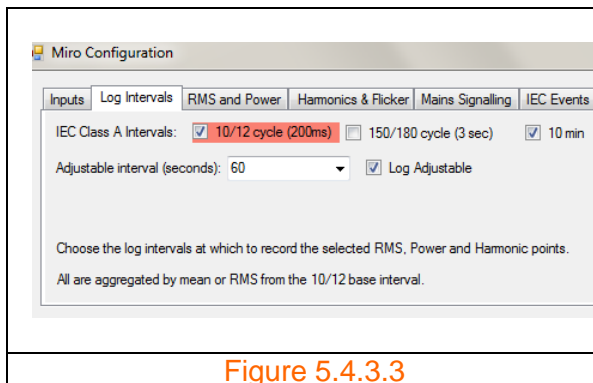

Figure 5.4.3.3

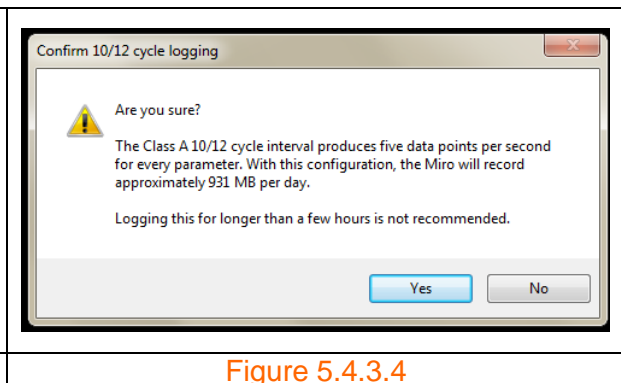

Figure 5.4.3.4

If the 10/12 cycle log interval is selected a warning message appears on the 'Miro Operations' window (as shown in figure 5.4.3.5) alerting the user that this selection will consume memory. As shown in figure 5.4.3.6, the message disappears when the 10/12 cycle log interval is deselected.

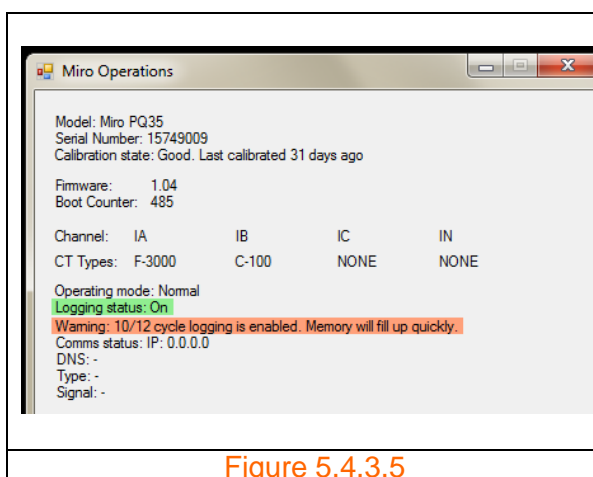

Figure 5.4.3.5

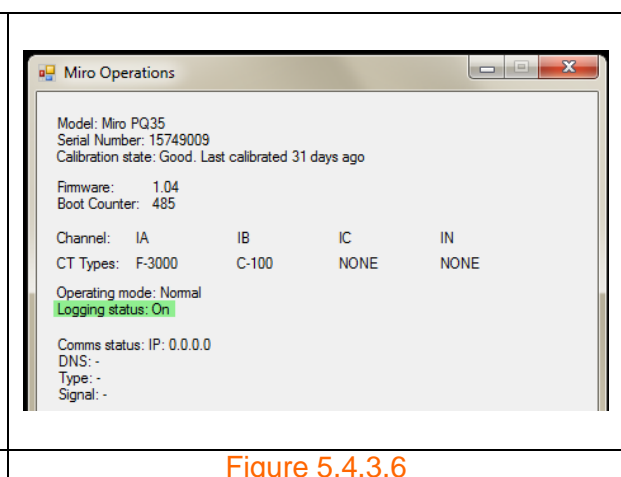

Figure 5.4.3.6

5.4.4 RMS and Power

The 'RMS and Power' tab shown in figure 5.4.4.1 provides key power quality parameters grouped together.

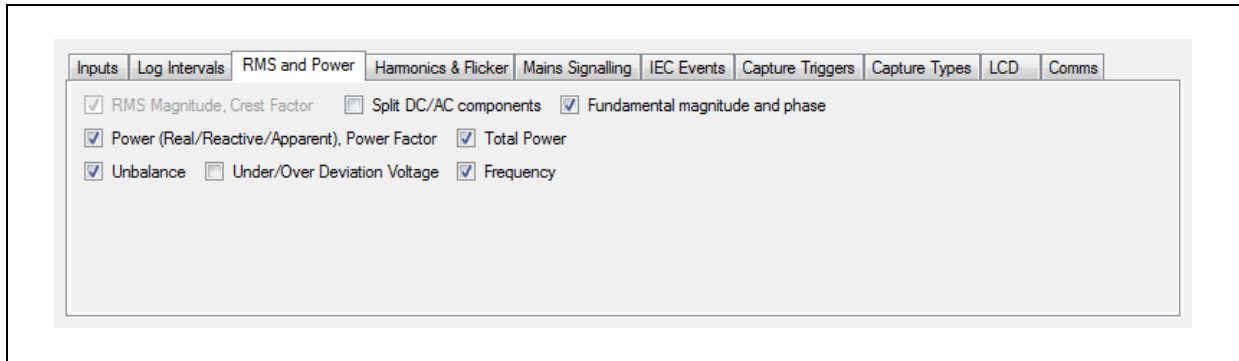

Figure 5.4.4.1

Groups include: 'RMS Magnitude, Crest Factor'; 'Split DC/AC components'; 'Fundamental magnitude and phase'; 'Power (Real/Reactive/Apparent), Power Factor'; 'Total Power'; 'Unbalance'; 'Under/Over Deviation Voltage'; and 'Frequency'.

Note that the 'RMS Magnitude, Crest Factor' measurements are permanently selected and cannot be changed by the user.

5.4.5 Harmonics & Flicker

The 'Harmonics & Flicker' tab shown in figure 5.4.5.1 provides options to select groups of harmonic magnitudes, phases and interharmonics.

Groups include: 'Harmonic Magnitudes 1-25'; 'Harmonic Magnitudes 26-50'; 'Harmonic Magnitudes 51-100'; 'Harmonic Phase 1-25'; 'Harmonic Phase 26-50'; 'Interharmonic Magnitudes 0-24'; 'Interharmonic Magnitudes 25-49'; 'Interharmonic Magnitudes 50-99'; and 'THD'.

Flicker indices 'Pst' and 'Plt' can be individually selected.

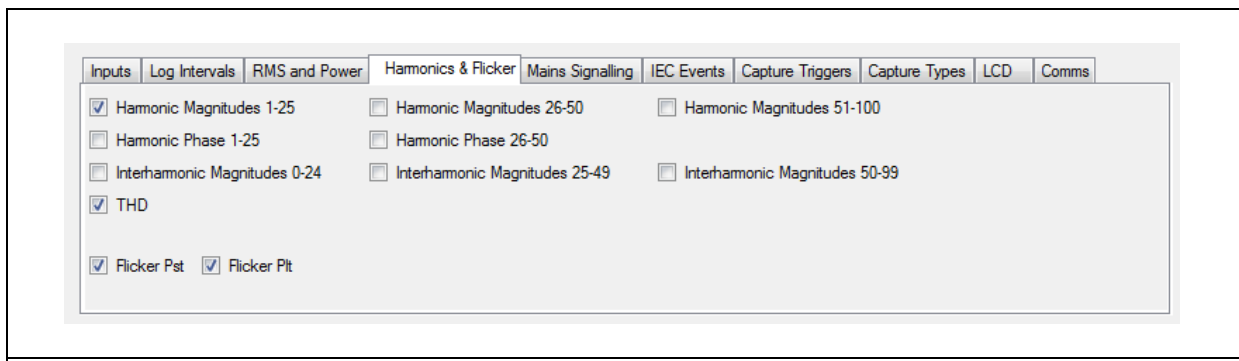

Figure 5.4.5.1

5.4.6 Mains Signalling

The 'Mains Signalling' tab is shown in figure 5.4.6.1.

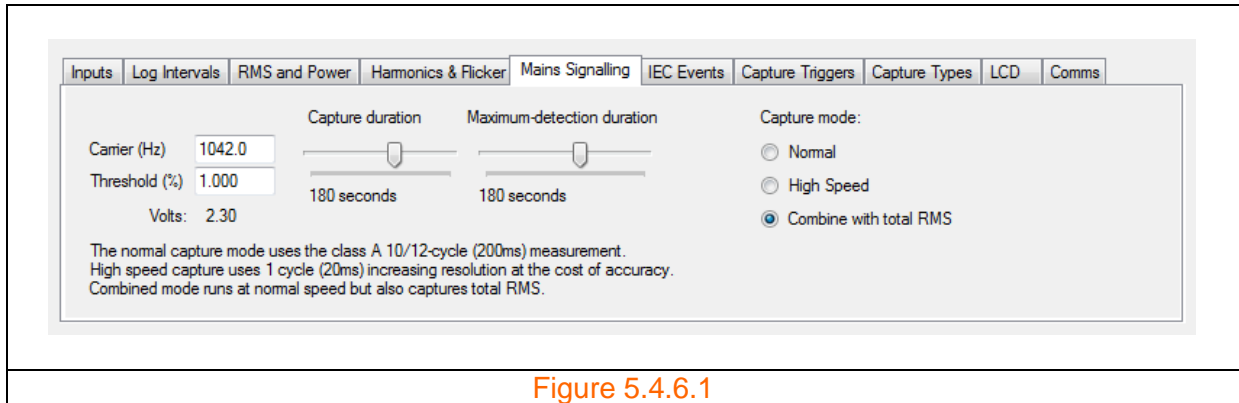

Figure 5.4.6.1

The detection threshold (%) is user settable and where the magnitude in volts is based on the nominal voltage. The carrier frequency in Hz is also user settable. The 'Capture duration' and 'Maximum detection duration' parameters are both user settable with ranges shown in figures 5.4.6.2 and 5.4.6.3.

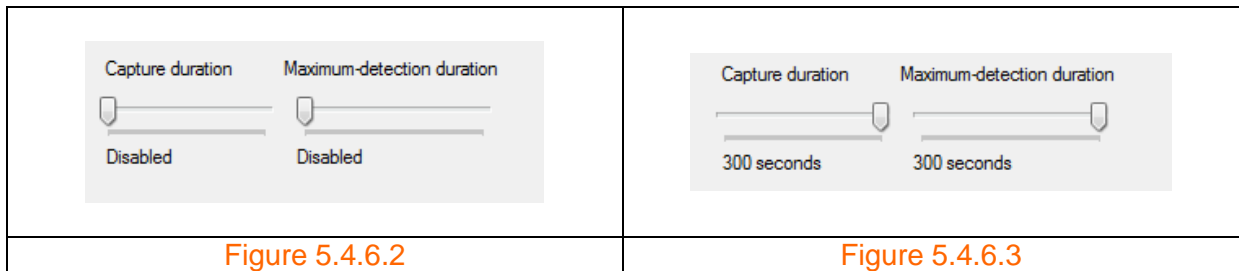

Figure 5.4.6.2

Figure 5.4.6.3

There are three capture modes for Mains Signalling and include: 'Normal'; 'High Speed'; and 'Combine with total RMS'. Definitions are provided in figure 5.4.6.1.

The 'Normal' capture mode uses the class A 10/12 cycle (200ms) measurement. The 'High Speed' capture uses one cycle (20ms), increasing resolution and trading off accuracy. The 'Combined with total RMS' mode runs at normal speed but also captures total RMS.

5.4.7 IEC events

The 'Dip', 'Swell', 'Interruption' and 'RVC' are all grouped as 'IEC Events' as shown in figure 5.4.7.1. The detection 'Threshold (%)' and 'Hysteresis (%)' are user settable. The magnitude in volts is based on the nominal voltage.

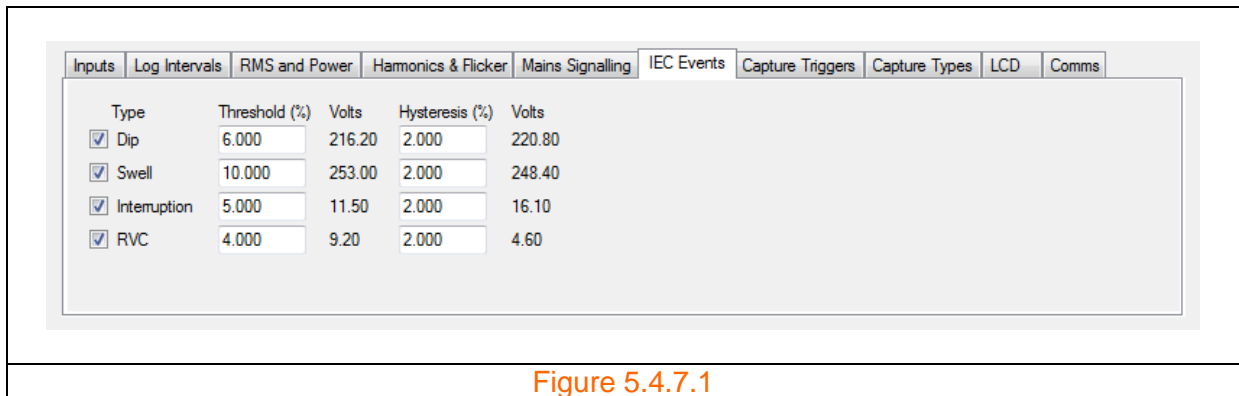

Figure 5.4.7.1

5.4.8 Capture triggers

The 'Capture Triggers' tab shown in figure 5.4.8.1 shows two trigger types, the 'Sliding Reference Trigger' and 'Transient Trigger'. The 'Sliding Reference Trigger' can be set to any voltage or current input channel and whose settable parameters are percent fall and rise.

The 'Transient Trigger' triggers from a voltage gradient value scaled in V/ms. Note, the value is approximate and limited by instrument bandwidth.

The 'Log single point' check box allows the dv/dt point at which the trigger occurs to be logged.

Event triggers are inhibited for the first minute after power up, to give time to ensure all leads are connected and for the sliding reference to settle.

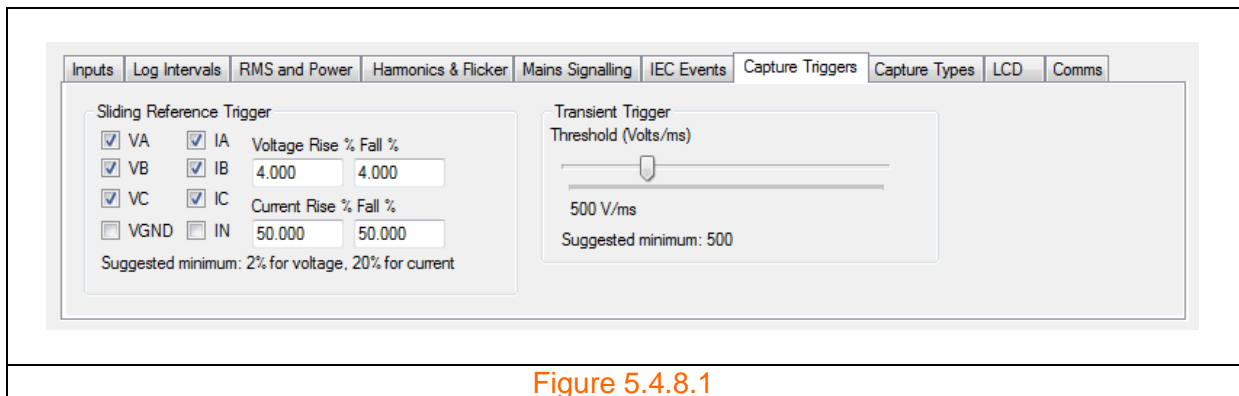

Figure 5.4.8.1

5.4.9 Capture types

The 'Capture Types' tab shown in figure 5.4.9.1 shows two capture types, the waveform and RMS. The triggers for the captures consist of 'IEC Events' plus those set under 'Capture Triggers'. With the 'Waveform Capture' the user has the option to select either a 'Short Capture' or a 'Long Capture'. The 'Long Capture' is particularly useful for capturing motor start waveforms.

Longer capture durations are available on request.



Figure 5.4.9.1

5.4.10 LCD pages

The 'LCD' tab shown in figure 5.4.10.1 shows the various pages that can be displayed on the graphical LCD.

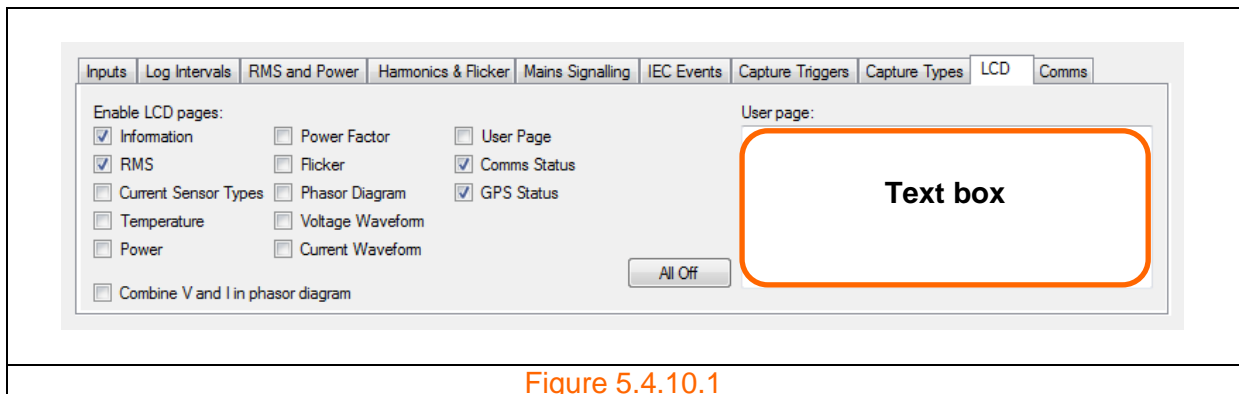

Figure 5.4.10.1

All pages are user selectable and will be displayed sequentially approximately every 2.5 seconds.

5.4.10.1 Information

The 'Information' page displays the:

- Model number;
- Serial number
- Firmware number;
- Amount of memory used in MB and as a percentage of total memory; and
- Free memory in MB.

5.4.10.2 RMS

The 'RMS' page displays the RMS voltage and current for each channel and also the frequency.

5.4.10.3 Current sensor types

The 'Current Sensor Types' page displays the type of current sensor which is attached to the current channel. If no current sensor is connected or an unapproved current sensor is

connected to the Miro, the display will show **NONE**, indicating that the Miro has not recognised the sensor.

5.4.10.4 Temperature

The **'Temperature'** page displays temperature readings for the two temperature channels.

5.4.10.5 Power

The **'Power'** page displays the real power (kW), the apparent power (kVA) and the reactive power (kvar) for each phase channel A, B and C, together with the total power for each power type.

5.4.10.6 Power factor

The **'Power Factor'** page displays the true power factor (TPF) and the displacement power factor (DPF) for each phase channel A, B and C, together with the negative and zero sequence voltage and current unbalances.

5.4.10.7 Flicker

The **'Flicker'** page displays the instantaneous flicker index (Pinst), the short term flicker index (Pst) and the long term flicker index (Plt) for each phase channel A, B and C.

5.4.10.8 Phasor diagram

The **'Phasor Diagram'** page displays the phasor diagrams for each voltage and current channel. The angle from the reference is also displayed for each channel.

5.4.10.9 Voltage waveform

The **'Voltage Waveform'** page displays the waveforms for each of the voltage channels A, B and C with two major gridlines above and below the horizontal axis. A magnitude for the highest gridline is displayed. The instrument automatically maximises the waveform to fit the screen.

5.4.10.10 Current waveform

The **'Current Waveform'** page displays the waveforms for each of the current channels A, B and C with two major gridlines above and below the horizontal axis. A magnitude for the highest gridline is displayed. The instrument automatically maximises the waveform to fit the screen.

5.4.10.11 User page

The **'User Page'** displays any text that is entered in the text box shown in figure 5.4.10.1.

5.4.10.12 Comms status

The **'Comms Status'** page displays the cellular communication platform information on the screen else the page displays **'Comms Disabled'** if no communications platform is enabled.

The communication platform information includes: State of the device (e.g. “Active, QMI”); IP address (e.g. “10.67.48.198”); DNS (e.g. “Yes”); Type (e.g. “4G”); Signal strength (e.g. “-75dBm”); and Band (e.g. “LTE band 3”).

A vertical signal level bar appears to the right hand side on the LCD when cellular communications is active. Refer to figures 5.4.10.12.1 and 5.4.10.12.2. The type of cellular platform is indicated underneath the vertical signal level bar.

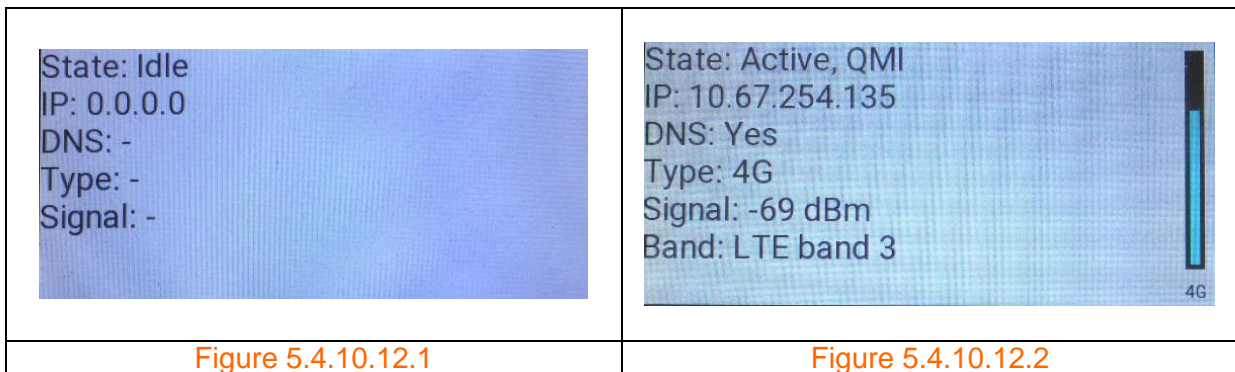

5.4.10.13 GPS status

The ‘GPS Status’ page displays the number of satellites in use and the Latitude and Longitude coordinates when the Miro has a GPS fix.

If the GPS antenna is connected and GPS signal found, then the ‘GPS’ label will appear above the log status, as shown in figure 5.4.10.13.1, indicating that a GPS signal has been detected. The date time will also change to amber with the word ‘ADJ’ appended to indicate that the Miro is adjusting its clock to match the GPS time.

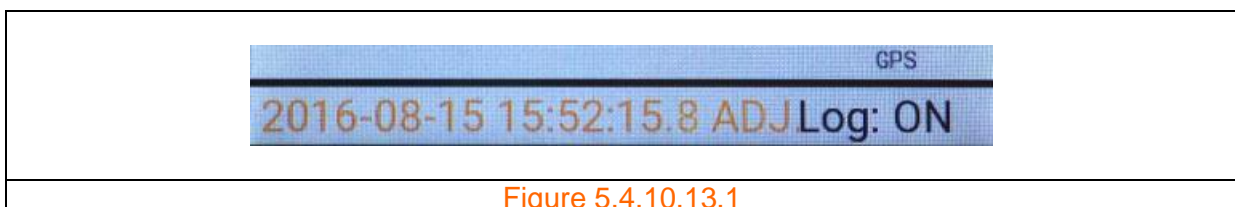

Once the clock has been adjusted the date time will change its colour to green, as shown in figure 5.4.10.13.2, indicating that the instrument time is now locked to GPS time.

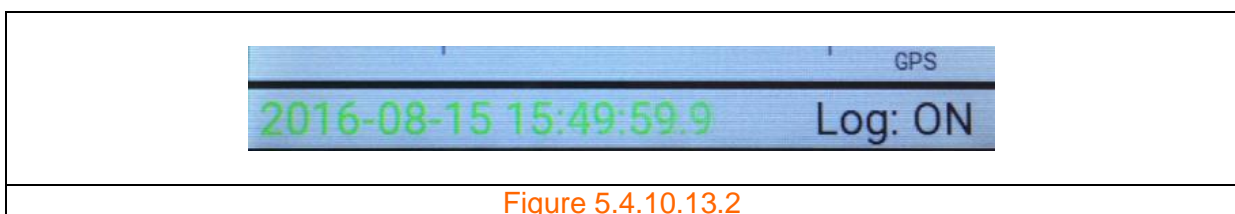

Now, if the GPS antenna is removed, the date time will soon revert back to the colour black and the instrument will retain its GPS date time.

5.4.10.14 Common page information

Each page is numbered and displays the date, time and log status 'Log: ON' or 'Log: OFF' at the bottom of each page on a single line as shown in figure 5.4.10.14.1.

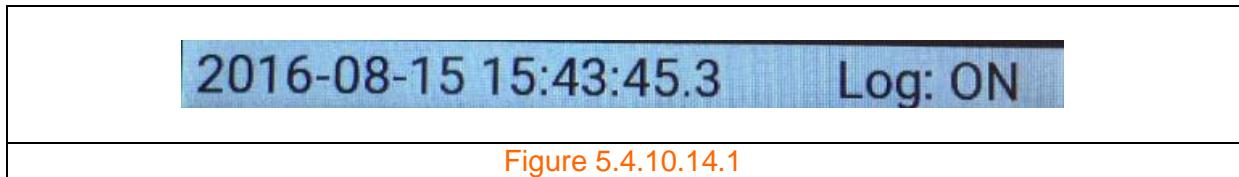

Figure 5.4.10.14.1

The user can pre-set future date-times for the 'Log start:' and 'Log stop:' for a delayed log start. In this case the log status will display 'Log: WAIT' until the date-time reaches the pre-set 'Log start:' value. Once the date-time reaches the 'Log stop:' value, the log status will display 'Log: FIN', indicating that the instrument has finished logging.

If the start time is in the past, then the Miro will start logging immediately on power up.

5.4.11 Comms

The 'Comms' tab shown in figure 5.4.11.1 is for the configuration of cellular communications. The user has the option to disable the communications by selecting 'Disabled'.

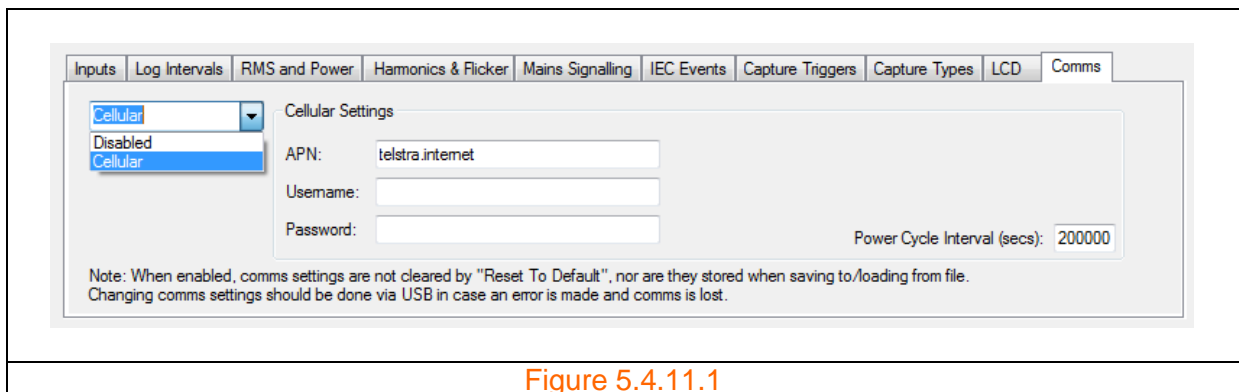

Figure 5.4.11.1

The 'Power Cycle Interval (secs)' input allows the user to set the desired communications power cycle interval.

5.4.11.1 Australian mobile phone networks band summary

The three mobile networks in Australia are owned and operated by Telstra, Optus and Vodafone. The numerous other service providers all work on one of these networks. The assigned frequency bands are summarised in the table below.

Mobile Network	2G (calls and text)	3G (calls, text and broadband)	4G / LTE (fast broadband)
Telstra	900MHz	850MHz (B5) 2100MHz (B1)	700MHz (B28) 900MHz (B8) 1800MHz (B3) 2100MHz (B1) 2600MHz (B7)
Optus & Virgin mobile	900MHz	900MHz (B8) 2100MHz (B1)	700MHz (B28) 1800MHz (B3) 2100MHz (B1) 2300MHz (B40) 2600MHz (B7)
Vodafone	900MHz	850MHz (B5) 900MHz (B8) 2100MHz (B1)	850MHz (B5) 1800MHz (B3)

Note (1): LTE - long term evolution.

5.4.11.2 Cellular module

We provide cellular modules that can connect to any of the three mobile networks listed in section 5.4.11.1, but may not necessarily connect to all frequency bands.

5.4.11.3 Cellular option outside Australia

For international customers - we can provide cellular modules that can connect to mobile networks outside Australia. Please contact our sales team and provide us the information listed below as we may need to customise for your requirements:

- (a) region;
- (b) local mobile network provider; and
- (c) cellular platforms (example 2G, 3G, or 4G) and associated frequencies and bands.

Example:

Region: New Zealand;
Local mobile network provider: Spark NZ network.
Cellular platforms: HSPA/3G requires 850MHz and 2100MHz.
 LTE/4G requires band 3 (1800MHz) and band 28 (700MHz).

5.5 Downloading and clearing memory

Downloading can be done at any time and will not interrupt logging.

5.5.1 Downloading data

Step 1: The user can download logged data by clicking the 'Download' button shown in figure 5.5.1.1 and ensuring that the 'Clear memory after download' checkbox is unchecked. A window shown in figure 5.5.1.2 appears allowing the user to save the downloaded file with a predefined file name to a folder.

Step 2: Modify the file name as desired and click the 'Save' button. Figure 5.5.1.3 shows the progress of the file being downloaded.

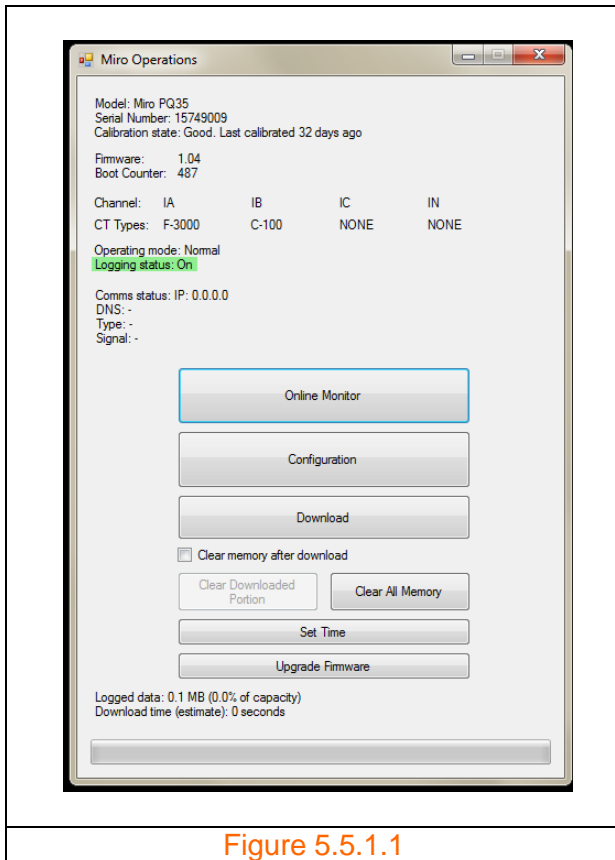

Figure 5.5.1.1

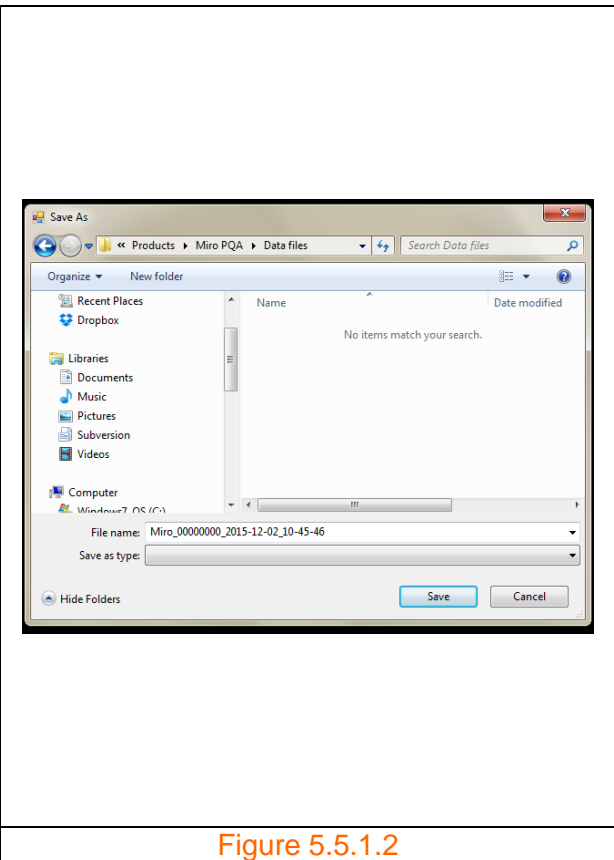

Figure 5.5.1.2

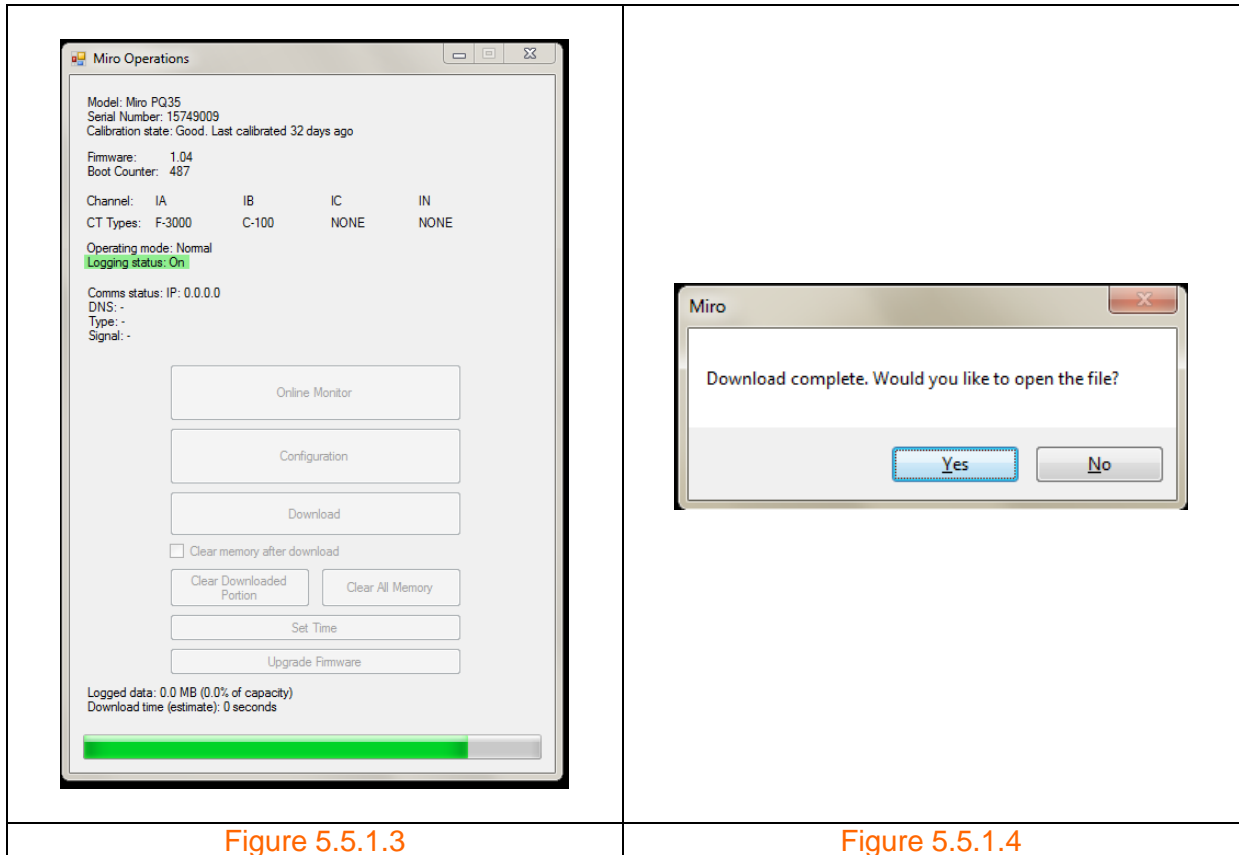

Figure 5.5.1.3

Figure 5.5.1.4

Step 3: Once completed, a message box appears as shown in figure 5.5.1.4 alerting the user that the file has been downloaded and provides an option for the user to open the file. Click as desired.

Step 4: As shown in figure 5.5.1.5 the 'Clear Download Portion' button on the 'Miro Operations' window is now active, allowing the user to now clear only the downloaded data.

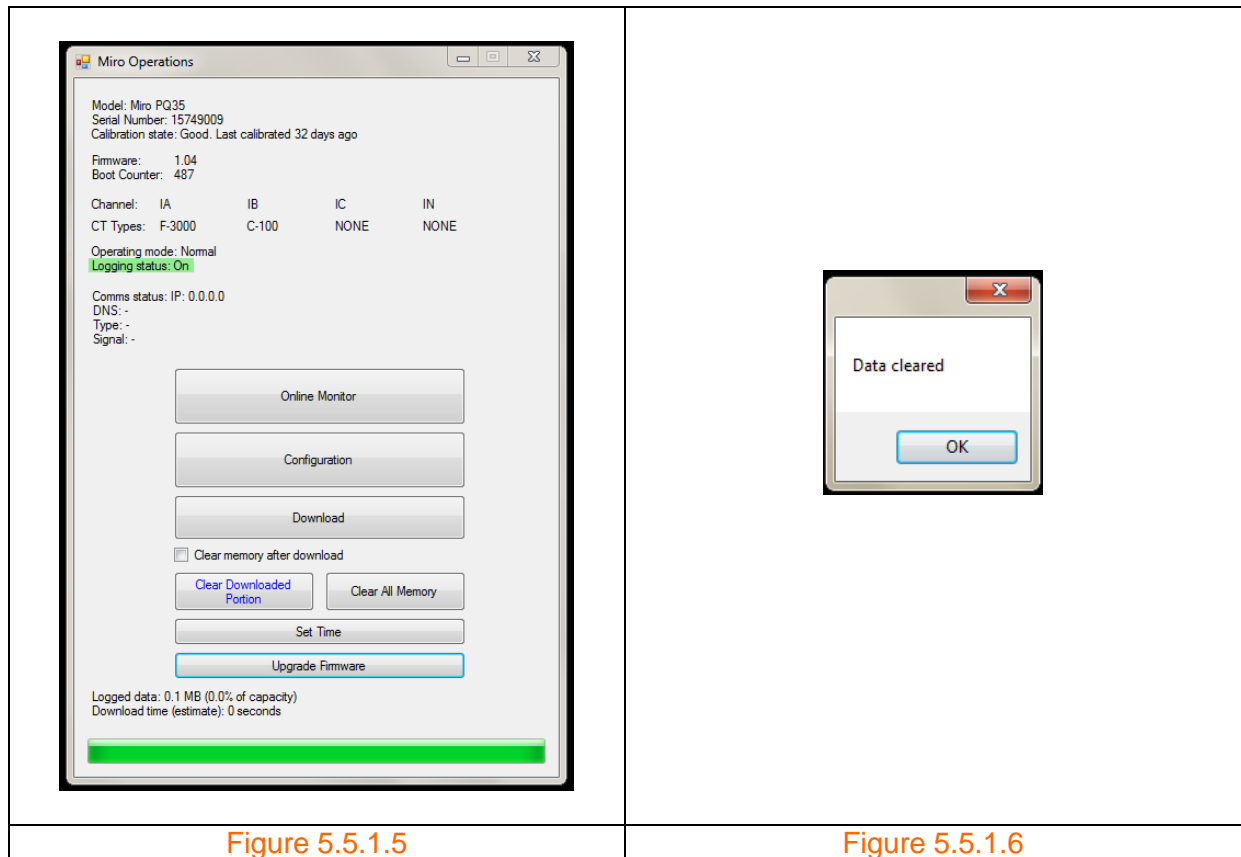
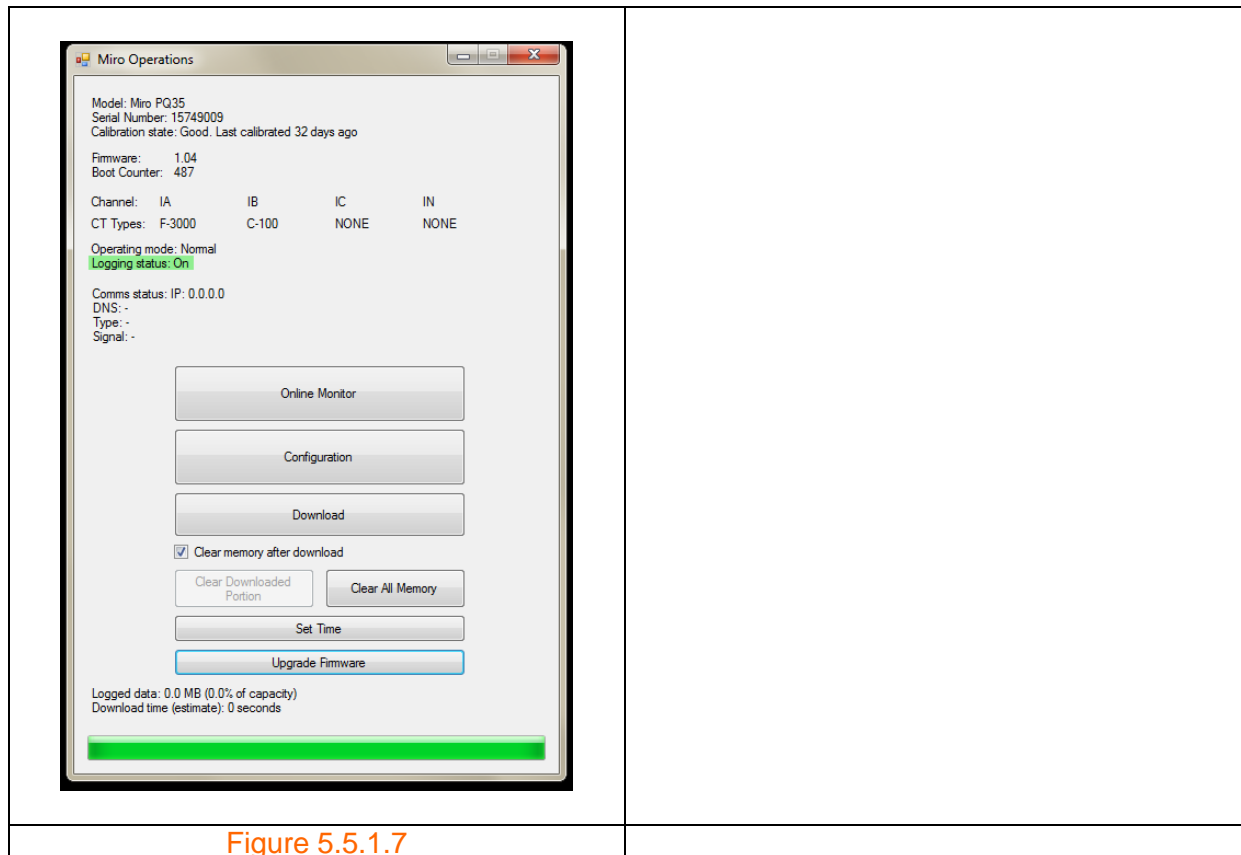

Figure 5.5.1.5

Figure 5.5.1.6

Step 5: Click the 'Clear Download Portion' button on the 'Miro Operations' window. A message window displaying 'Data cleared' appears as shown in figure 5.5.1.6.

Click the 'OK' button and the message box disappears. The 'Miro Operations' window now appears as shown in figure 5.5.1.7, with the progress bar still fully highlighted, but with the 'Clear Download Portion' button now inactive.



5.5.2 Downloading with clear memory

Step 1: The user can download logged data and clear memory immediately after the download by clicking the 'Download' button shown in figure 5.5.2.1 and ensuring that the 'Clear memory after download' checkbox is checked. A window shown in figure 5.5.2.2 appears allowing the user to save the downloaded file with a predefined file name to a folder.

Step 2: Modify the file name as desired and click the 'Save' button. Figure 5.5.2.3 shows the progress of the file being downloaded.

Step 3: Once completed, a message box appears as shown in figure 5.5.2.4 alerting the user that the file has been downloaded, memory cleared and provides an option for the user to open the file. Click as desired.

The 'Miro Operations' window now appears as shown in figure 5.5.2.5, with the progress bar still fully highlighted and all other buttons active again.

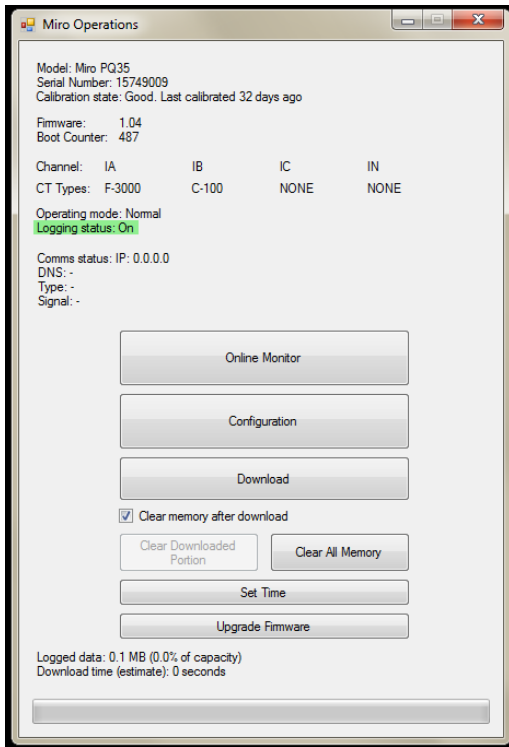

Figure 5.5.2.1

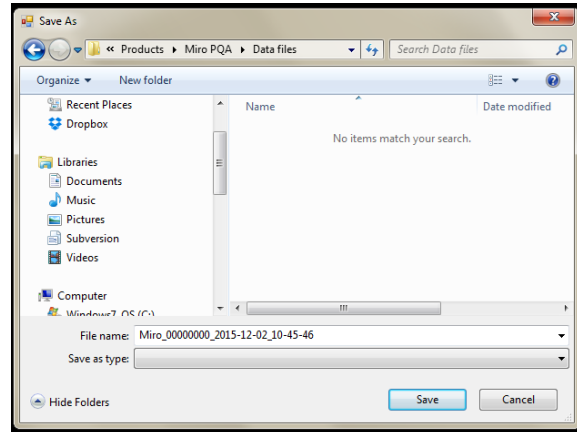

Figure 5.5.2.2

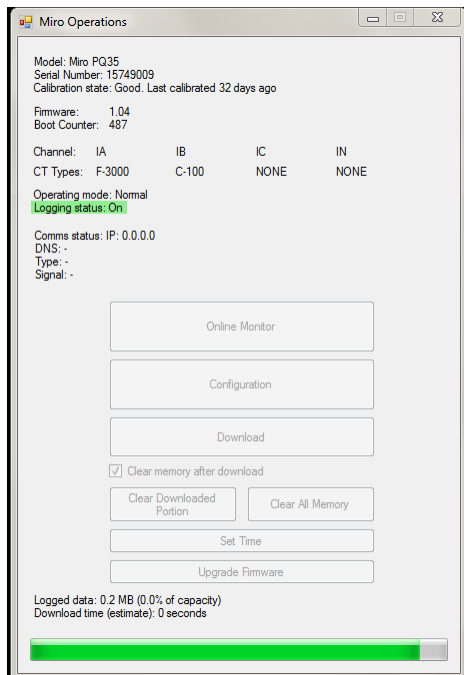

Figure 5.5.2.3

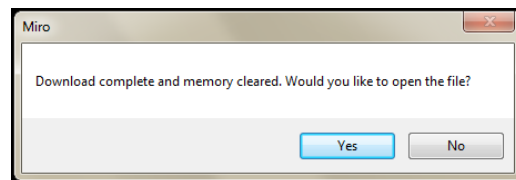
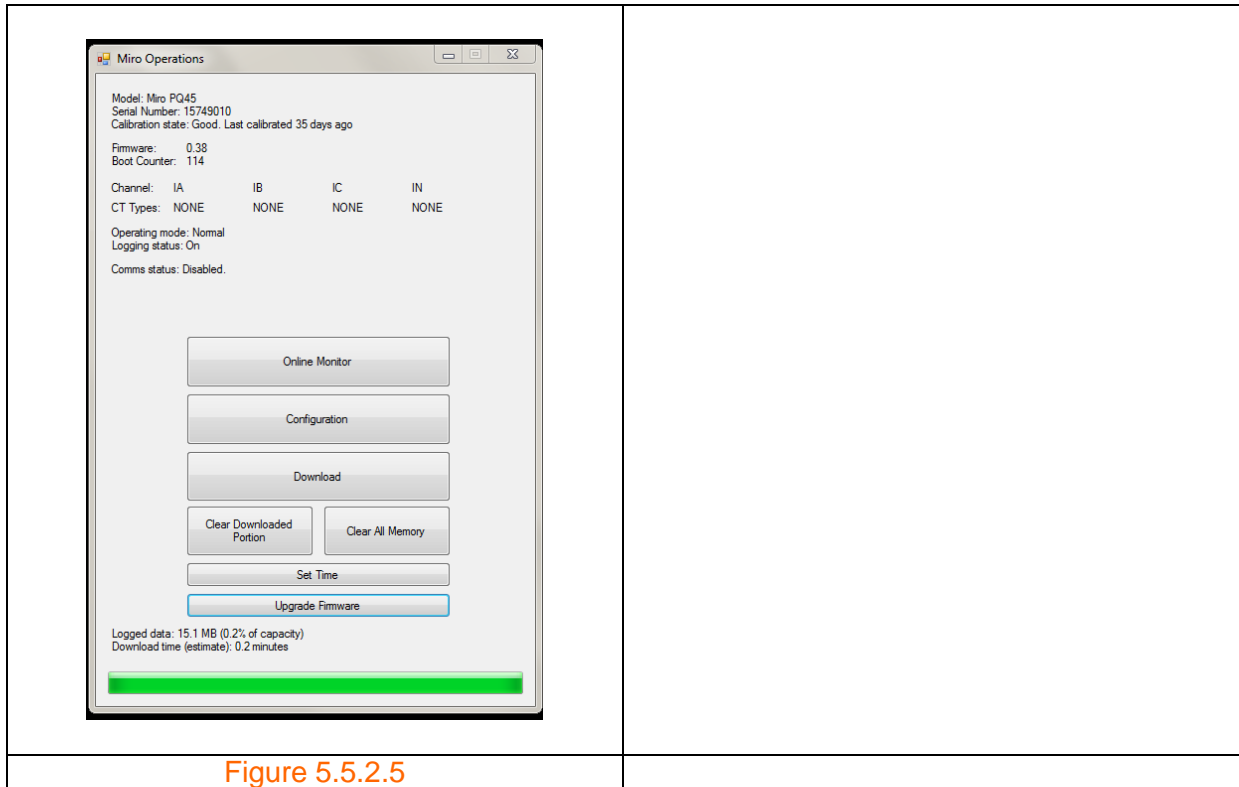

Figure 5.5.2.4



5.6 Clearing memory

As shown in figure 5.5.5 the 'Clear Download Portion' button is now active and provides the user with the option to clear only that portion of data that was actually downloaded and preserves the data that the instrument was logging whilst downloading. This allows for numerous sequential downloads with no gaps in the data.

If the 'Clear Download Portion' button is clicked then a message box appears as shown in figure 5.5.6, confirming that data is cleared.

If the 'Clear All Memory' button is clicked instead (before any downloaded data has been cleared) then a message box appears as shown in figure 5.5.7.

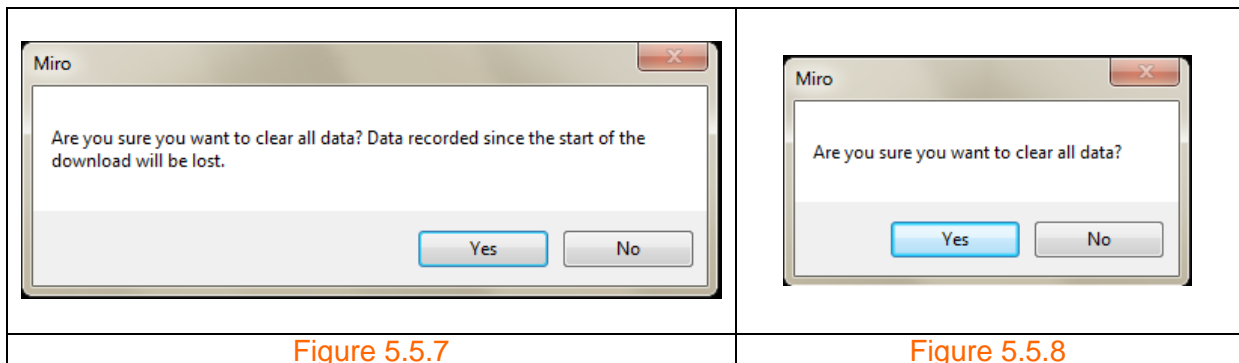

If the 'Clear All Memory' button is clicked after downloaded data has been cleared then a message box appears as shown in figure 5.5.8.

5.7 Set time

Clicking on the 'Set Time' button will set the RTC in the Miro to the PC time.

5.8 Firmware update

Step 1: Click on the 'Upgrade Firmware' button shown in figure 5.8.1. A window opens, as shown in figure 5.8.2, allowing the user to browse folders to select an updated firmware file.

Step 2: Select the desired file. The updated file will automatically load into the Miro.

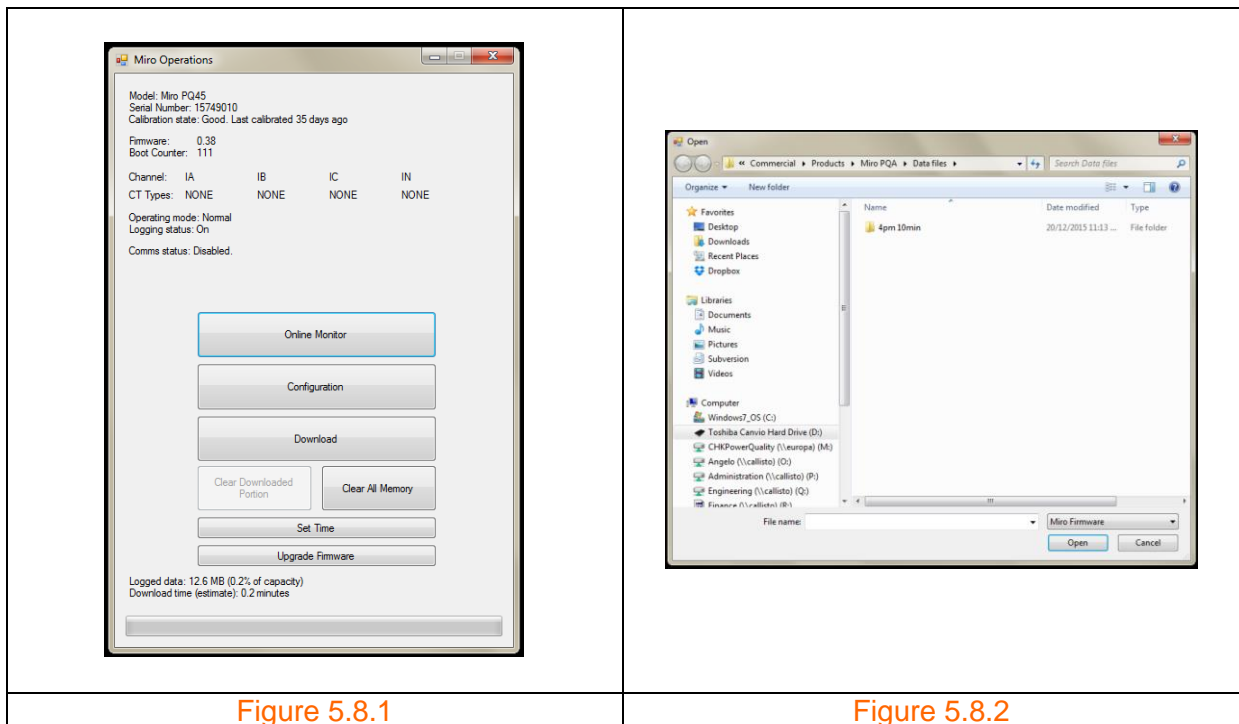

5.9 Miro data viewer

Clicking on the 'Open Data File' button shown in figure 5.9.1 will open the window shown in figure 5.9.2 allowing the user to select a 'Miro' file.



Figure 5.9.1

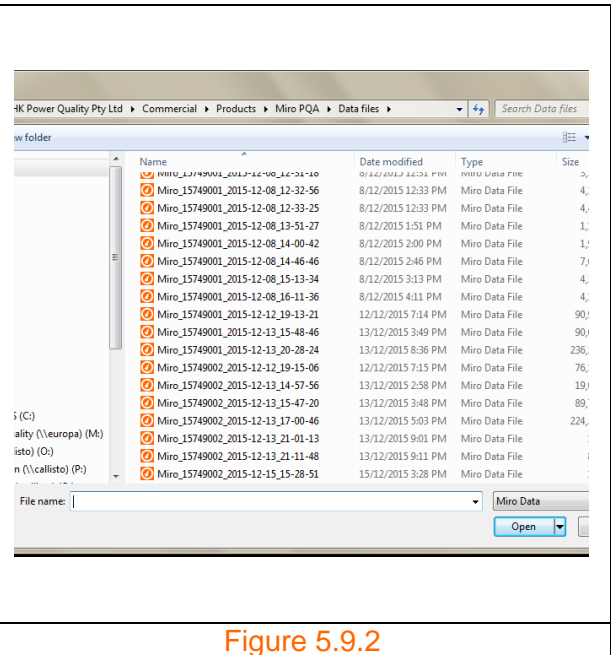

Figure 5.9.2

Select the desired 'Miro' file. The selected file is opened with information displayed in the 'Miro Data View' window or viewer as shown in figure 5.9.3. The Viewer incorporates menus and graphical features that allow the user to analyse the downloaded data file.

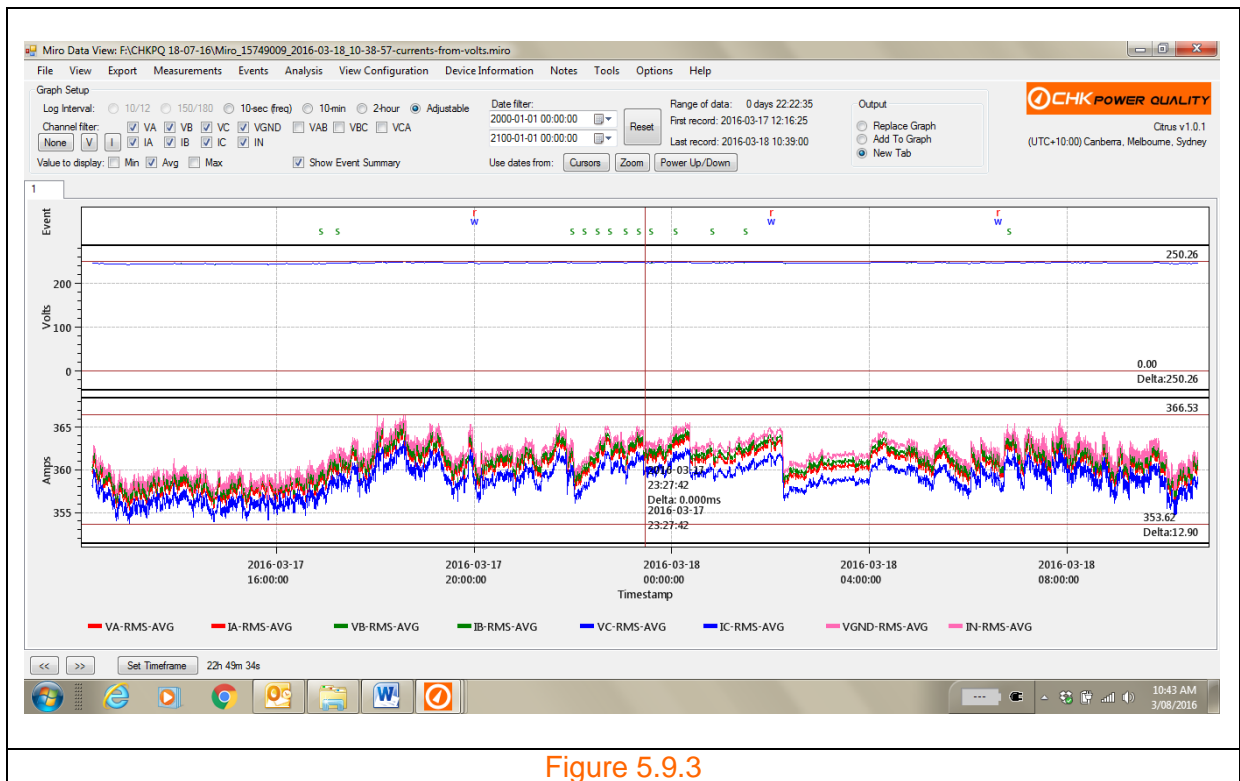
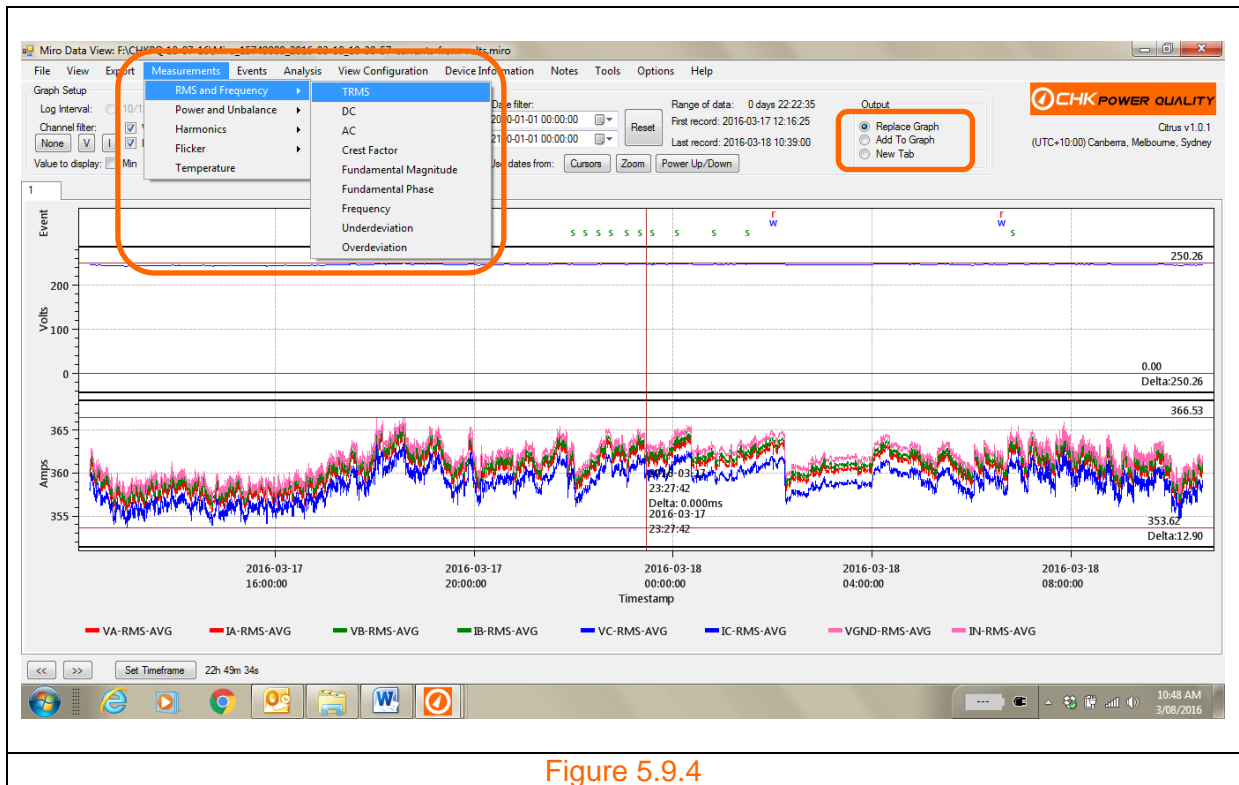

Figure 5.9.3

The default information displayed upon selecting a file is the 'TRMS' voltage and current measurements. The user can reload the default information by selecting 'Replace Graph' and 'TRMS' as shown in figure 5.9.4.



5.9.1 File

5.9.1.1 Open

The user is able to open a file in a new viewer window by two methods.

Method 1

Step 1: Click the 'File' menu shown in figure 5.9.1.1.1. A drop down box appears as shown in figure 5.9.1.1.2.

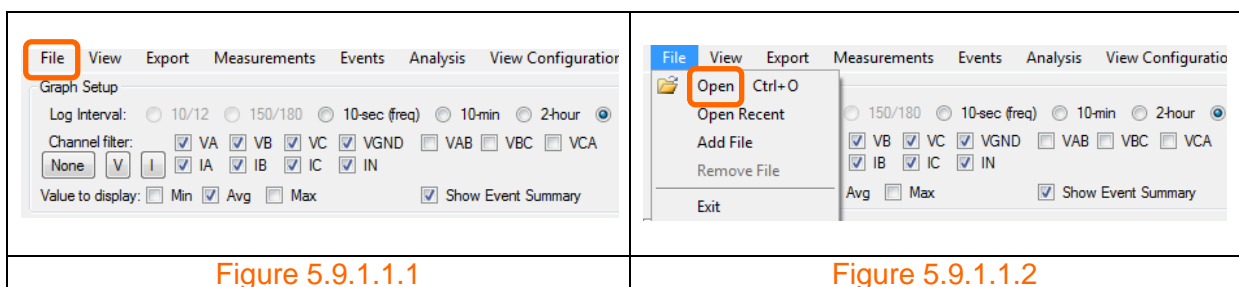

Step 2: Hover and click on 'Open'. The user is prompted to select the same file or another file as shown in figure 5.9.2. The additional window is shown in figure 5.9.1.1.3.

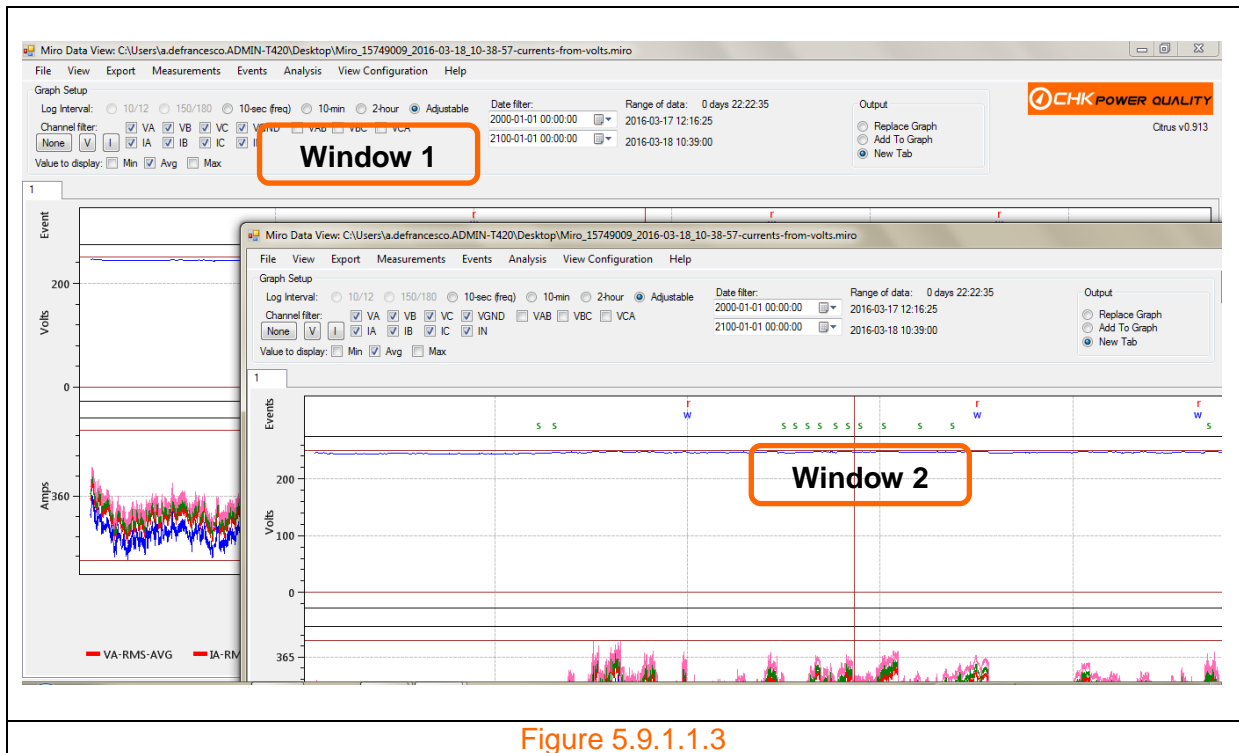

Method 2

The user is able to double click on a 'Miro' file, located in any folder, which then opens the file viewer window. The user is able to open multiple windows from the same or different data files. The file viewer automatically graphs the file data to display Volts/Amps as shown in figure 5.9.3.

5.9.1.2 Add file

The user is able to add a file to an existing viewer window.

Step 1: Click the 'File' menu shown in figure 5.9.1.2.1. A drop down box appears as shown in figure 5.9.1.2.2.

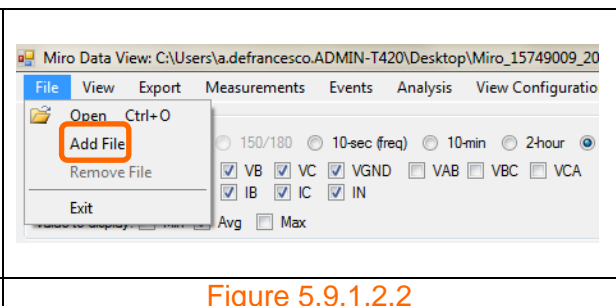
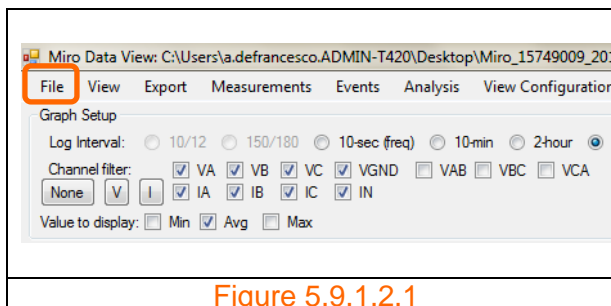

Step 2: Hover and click on 'Add File'. Additional data is now displayed together (overlay) with data from the previous file as shown in figure 5.9.1.2.3.

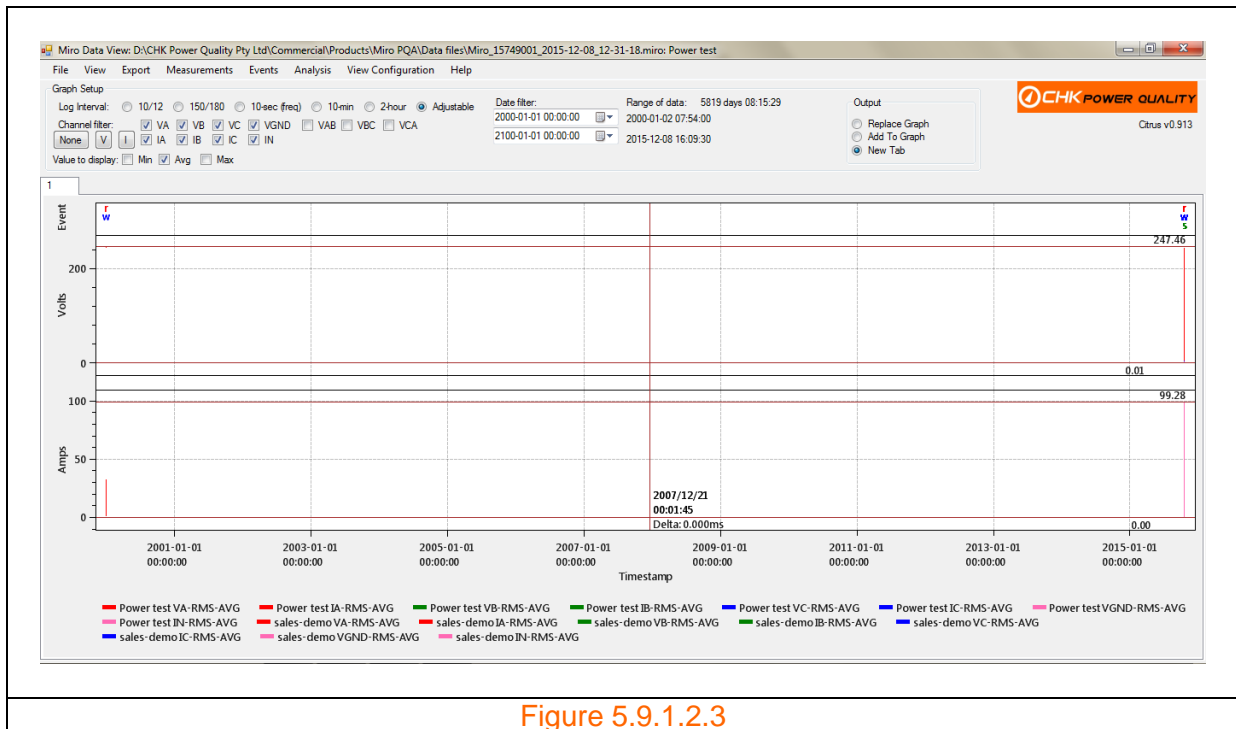

Figure 5.9.1.2.3

Note, as shown in figure in figure 5.9.1.2.4, the legend now also includes a description identifier to distinguish between the data traces from the two files.

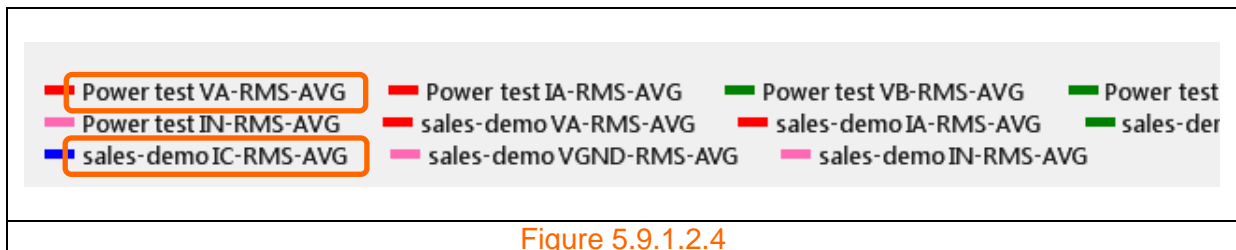

Figure 5.9.1.2.4

In the above case, the description identifier for the original data is 'sales-demo' and 'Power test' for the additional data.

As shown in figure 5.9.3 no description identifier is appended to the legend when only one file is open.

Multiple files can be added.

5.9.1.3 Remove file

The user is able to remove a file to an existing viewer window if more than one file has been added. Note that 'Remove File' option shown in figure 5.9.1.2.2 is inactive.

Step 1: Click the 'File' menu shown in figure 5.9.1.3.1. A drop down box appears as shown in figure 5.9.1.3.2. The 'Remove File' option shown in figure 5.9.1.3.2 is now active.

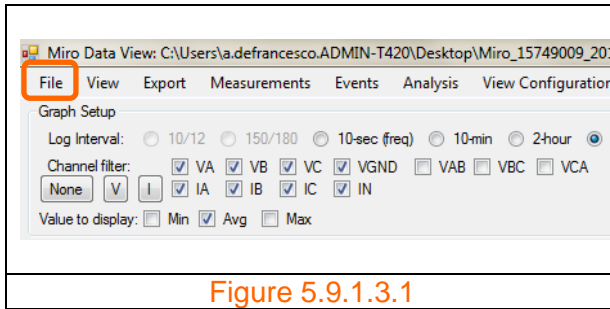

Figure 5.9.1.3.1

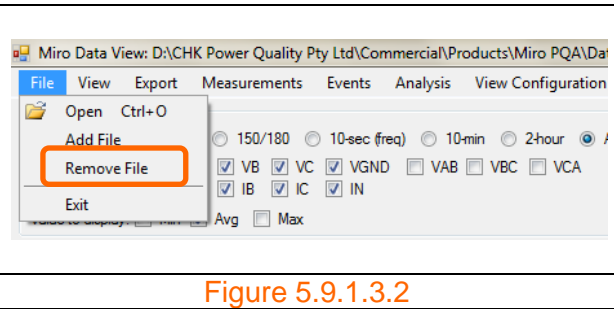

Figure 5.9.1.3.2

Step 2: Hover and click on 'Remove File'. A window appears listing all open files as shown in figure 5.9.1.3.3.

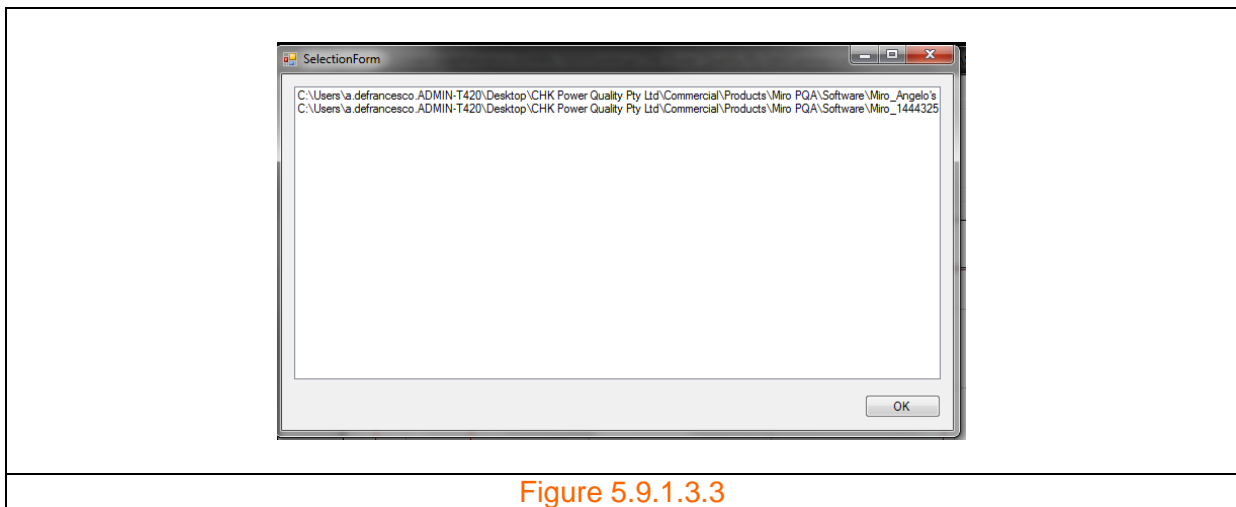

Figure 5.9.1.3.3

Step 3: Select the file you wish to remove and click on the 'OK' button.

5.9.1.4 Exit

The user is able to close the file viewer by two methods.

Method 1

Step 1: Click the 'File' menu shown in figure 5.9.1.4.1. A drop down box appears as shown in figure 5.9.1.4.2.

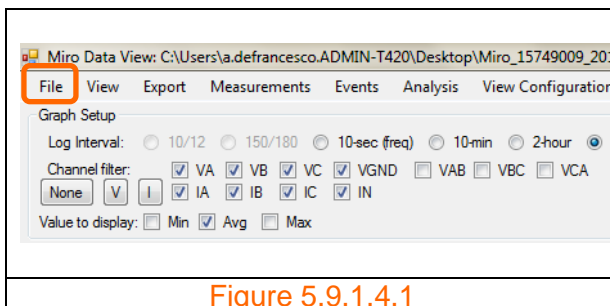

Figure 5.9.1.4.1

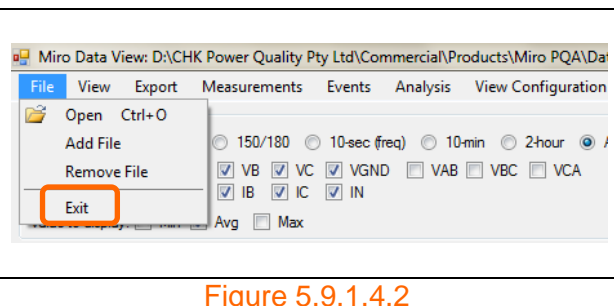
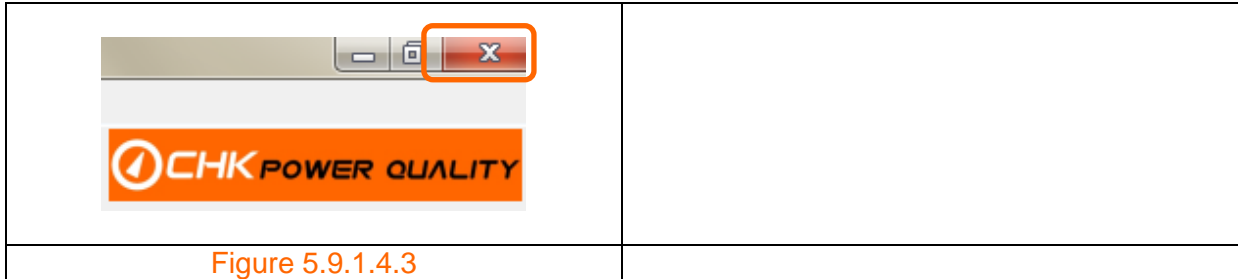

Figure 5.9.1.4.2

Step 2: Hover and click on 'Exit'.

Method 2

Step 1: Click the 'X' button located above the company logo as shown in figure 5.9.1.4.3.



5.9.2 View

5.9.2.1 Save view to log file

You wish to save the view shown in figure 5.9.2.1.1.

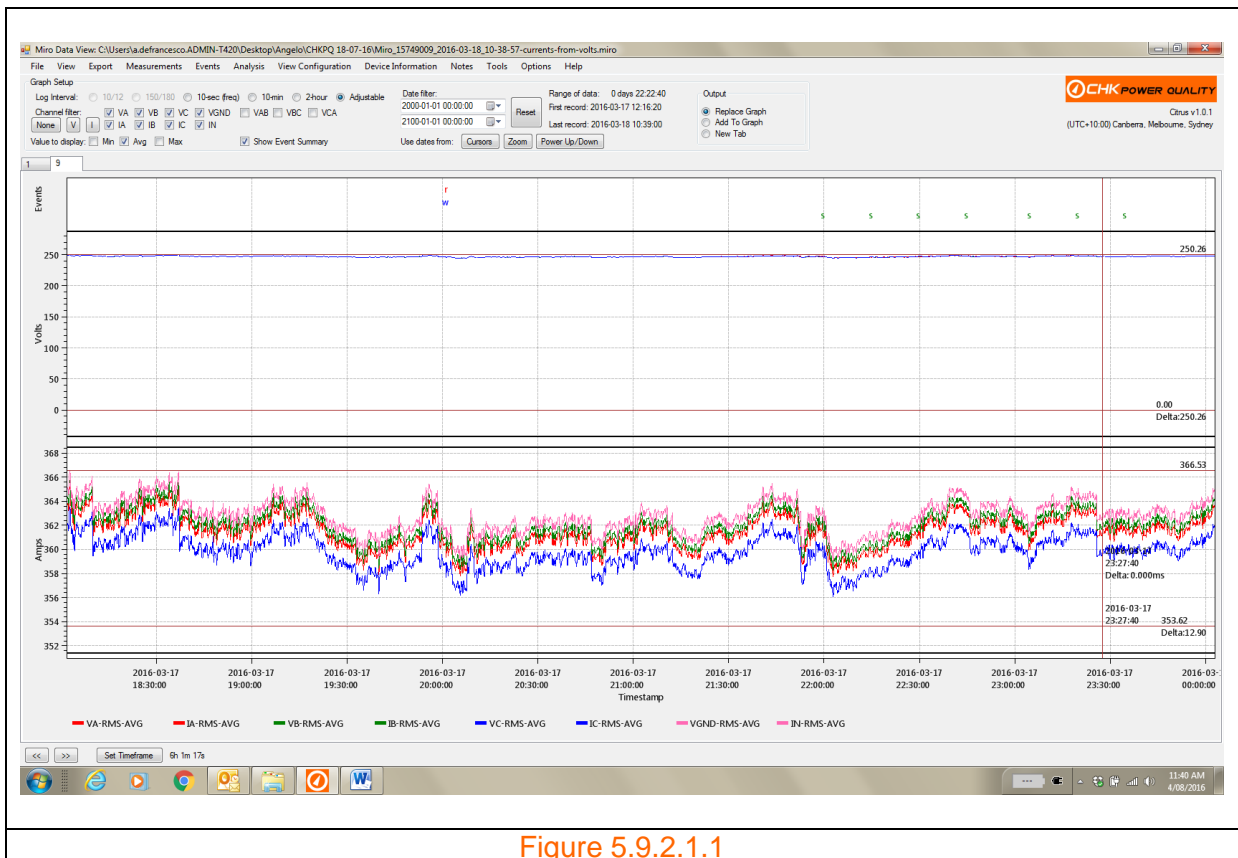

Step 1: Click the 'View' menu shown in figure 5.9.2.1.2. A drop down box appears as shown in figure 5.9.2.1.3.

Step 2: Hover and click on 'Save view to log file'. A message box appears as shown in figure 5.9.2.1.4 confirming the saved view.

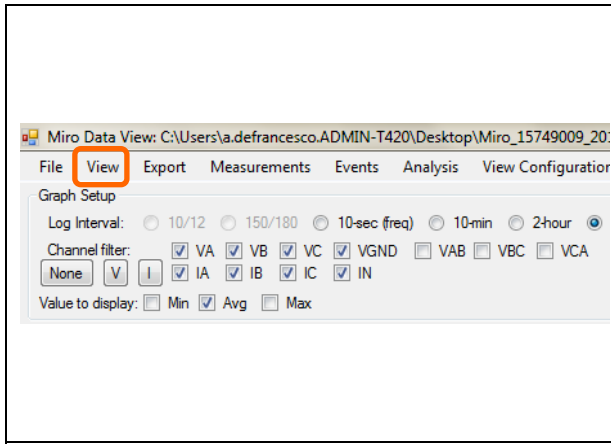

Figure 5.9.2.1.2

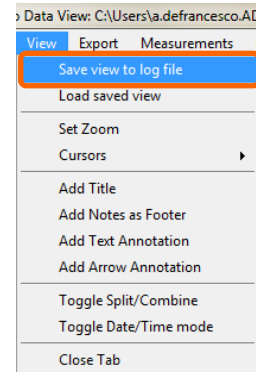

Figure 5.9.2.1.3

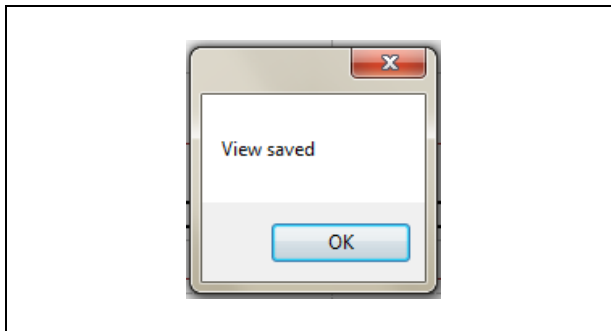

Figure 5.9.2.1.4

5.9.2.2 Load saved view

You wish to retrieve the view shown in figure 5.9.2.1.1.

Step 1: Click the 'View' menu shown in figure 5.9.2.2.1. A drop down box appears as shown in figure 5.9.2.2.2.

Step 2: Hover and click on 'Load saved view'. A list box appears as shown in figure 5.9.2.2.3 allowing the user to select a view file.

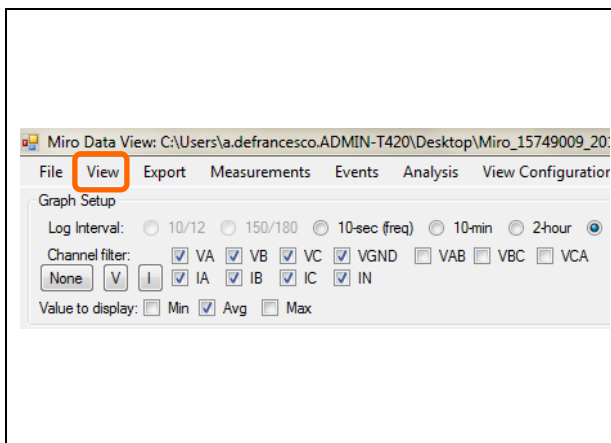

Figure 5.9.2.2.1

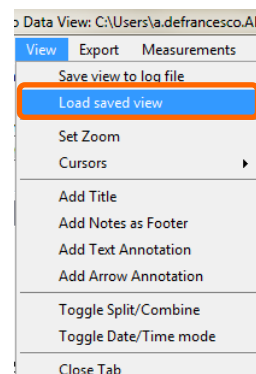

Figure 5.9.2.2.2

Step 3: Select the desired view file and click 'OK'. The view will be loaded as shown in figure 5.9.2.2.4.

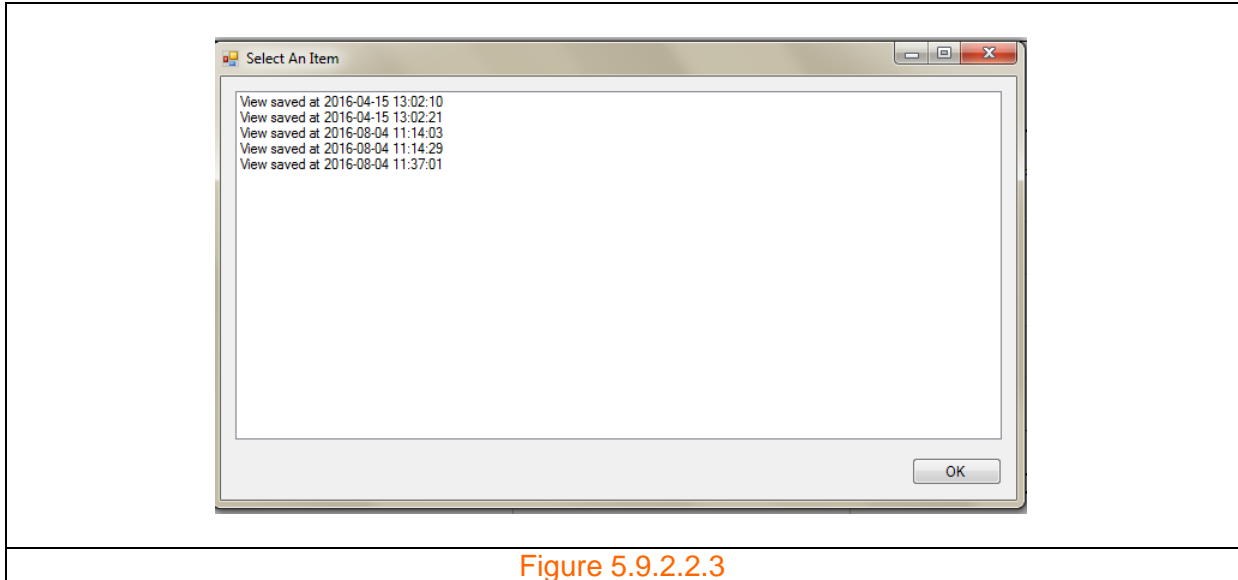

Figure 5.9.2.2.3

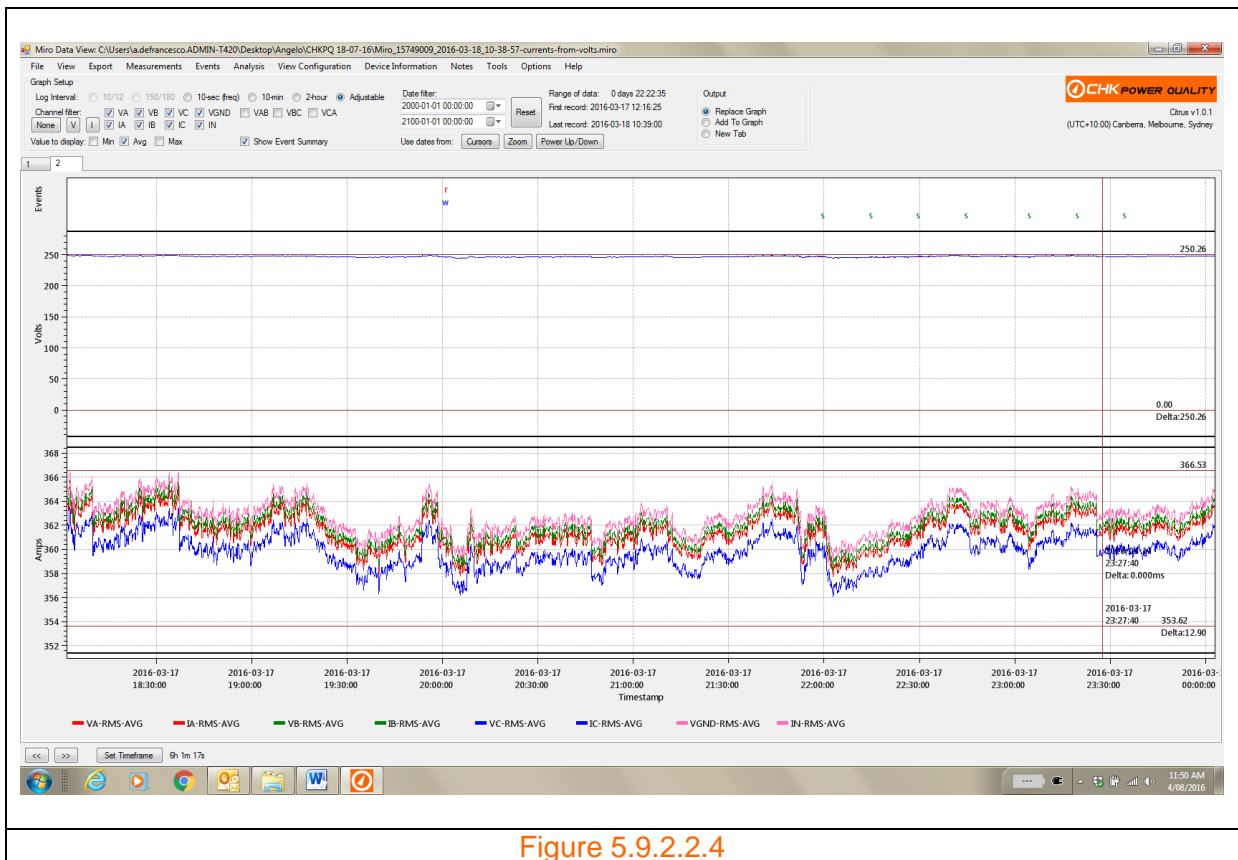
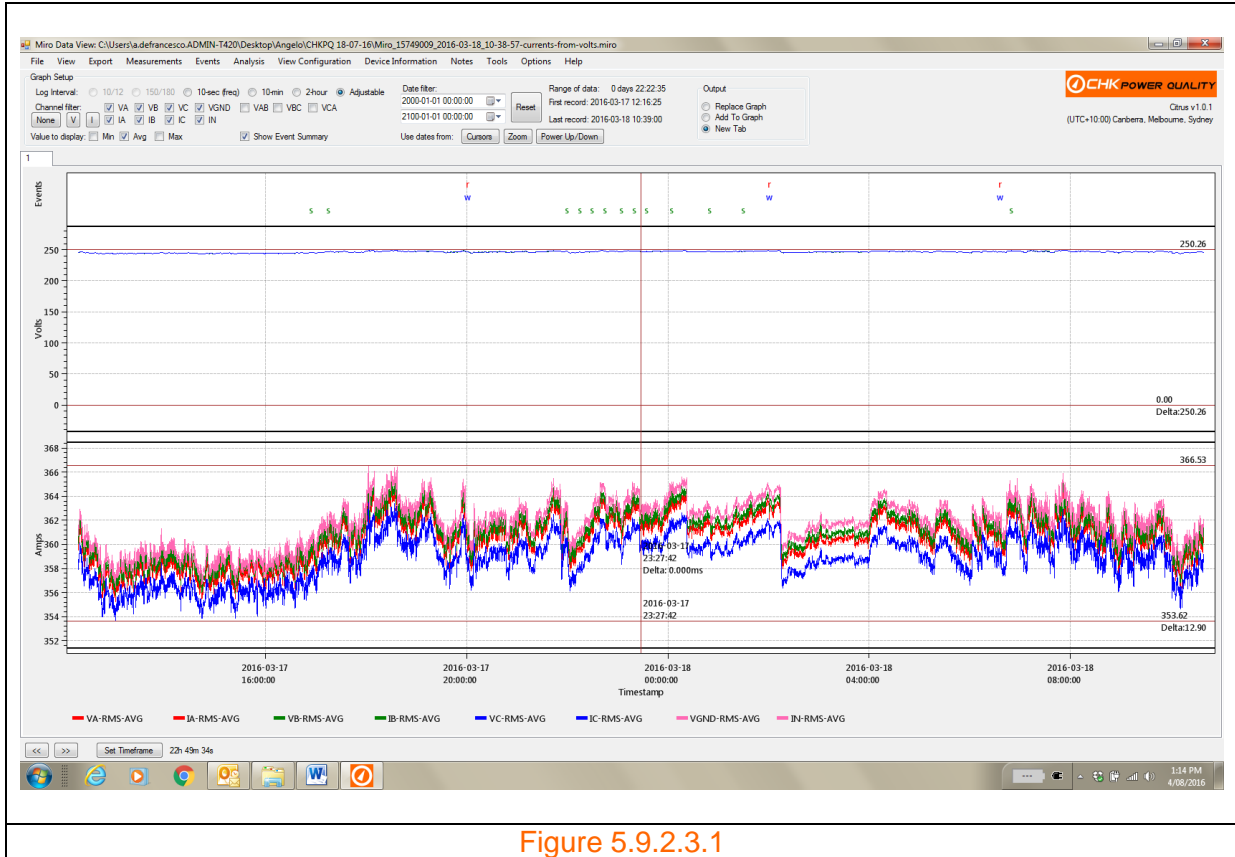

Figure 5.9.2.2.4

5.9.2.3 Set zoom

The set zoom feature allows the user to set the minimum and maximum values for both the voltage and current scales.

Assuming the user wishes to change the scales for the graphs shown in figure 5.9.2.3.1.



Step 1: Click the 'View' menu shown in figure 5.9.2.3.1. A drop down box appears as shown in figure 5.9.2.3.2.

Step 2: Hover and click on 'Set Zoom'. A list box appears as shown in figure 5.9.2.3.3 allowing the user to select 'VOLTS' or 'AMPS'.

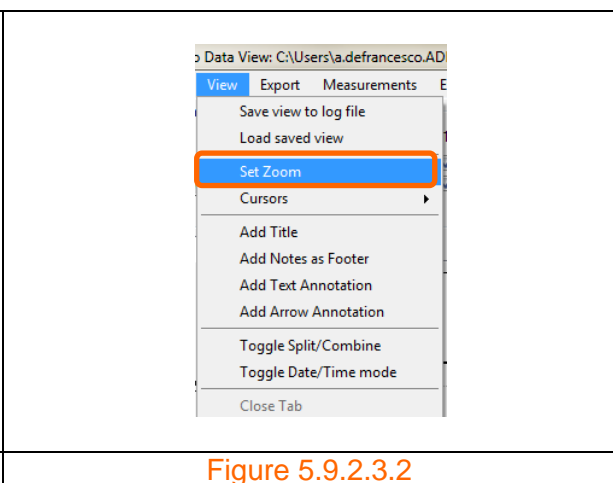
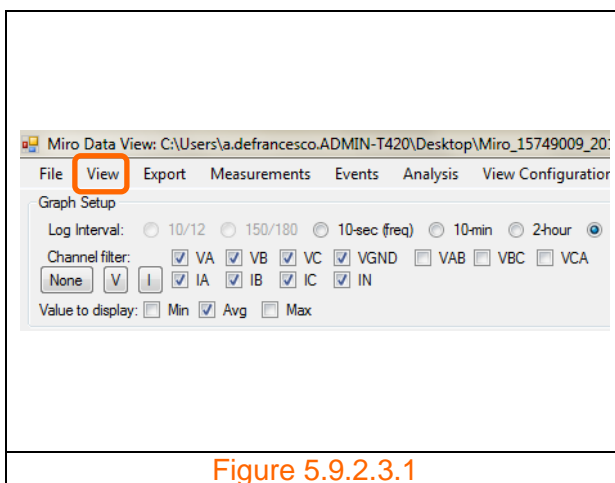

Step 3: Click on 'VOLTS'. An input box appears as shown in figure 5.9.2.3.4. The predefined level in the input box is the value that the minimum is currently set to. The user can alter this level.

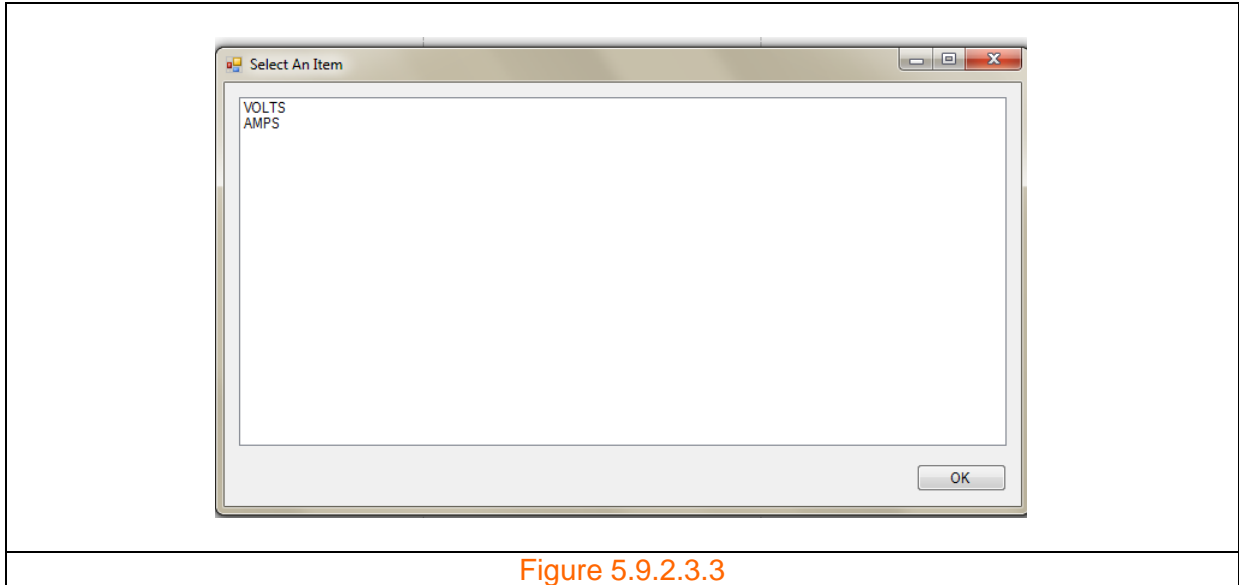

Figure 5.9.2.3.3

Step 4: In this case, set the level to 240 and click 'OK'. An input box appears as shown in figure 5.9.2.3.5. The predefined level in the input box is the value that the maximum is currently set to. The user can alter this level.

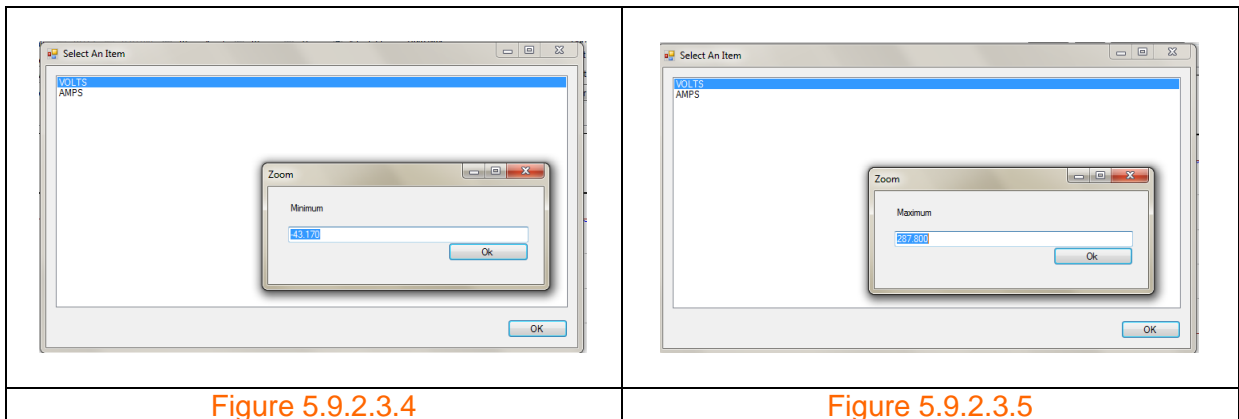
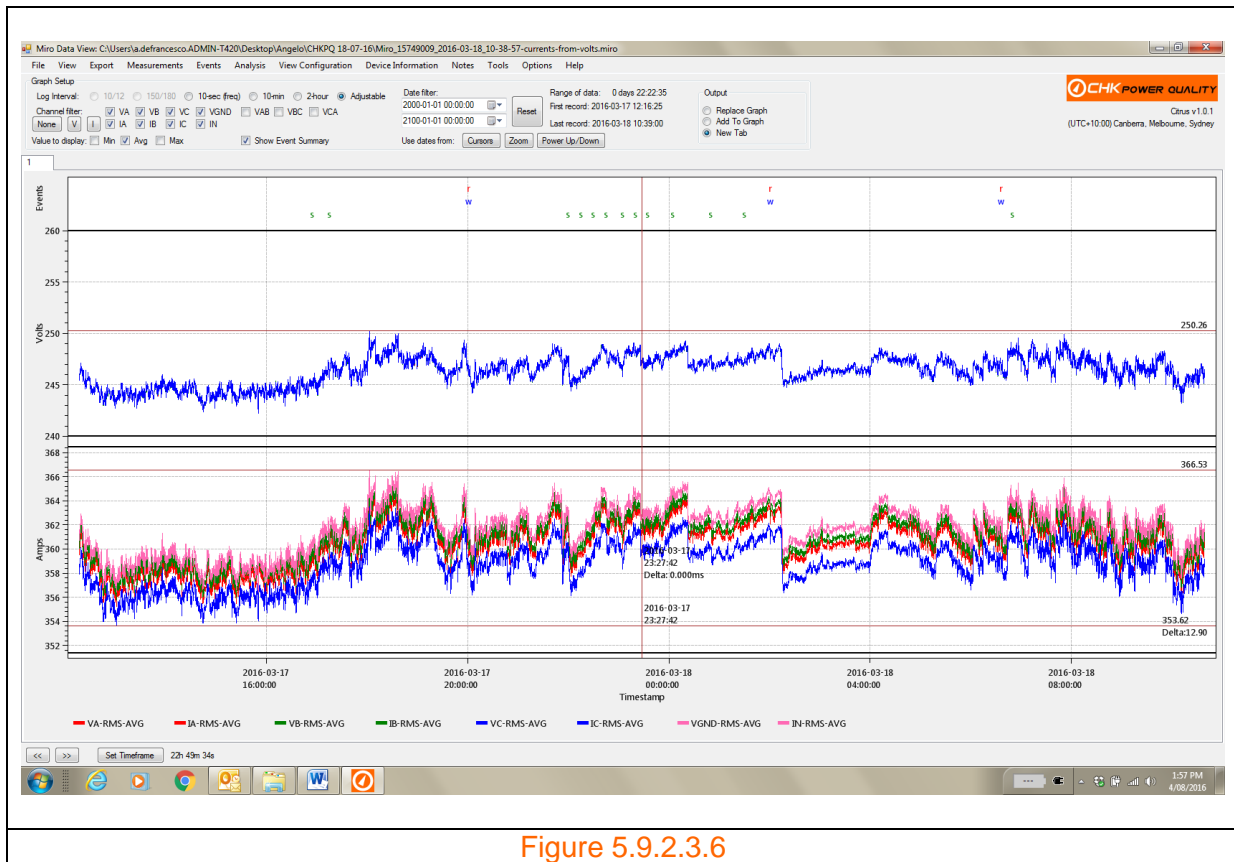

Figure 5.9.2.3.4

Figure 5.9.2.3.5

Step 5: In this case, set the level to 260 and click 'OK'. The scale for the voltage graph shown in figure 5.9.2.3.1 has now been changed to that shown in figure 5.9.2.3.6.



5.9.2.4 Cursors

The user is able to insert cursors for voltage and current graphs.

Step 1: Click the 'View' menu shown in figure 5.9.2.4.1. A drop down box appears as shown in figure 5.9.2.4.2.

Step 2: Hover and click on 'Cursors'. A submenu appears listing the various available cursors as shown in figure 5.9.2.4.3.

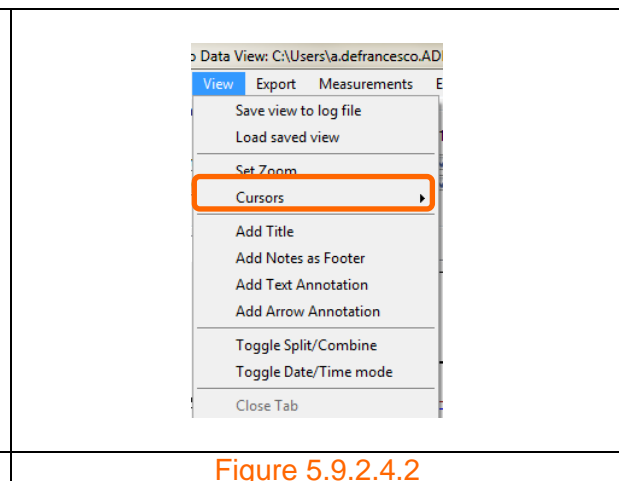
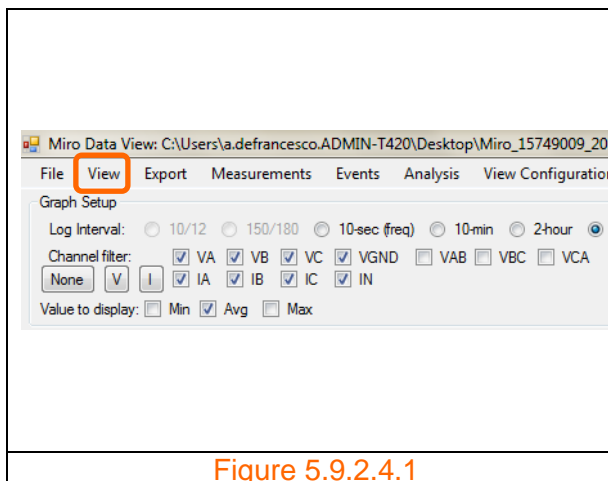

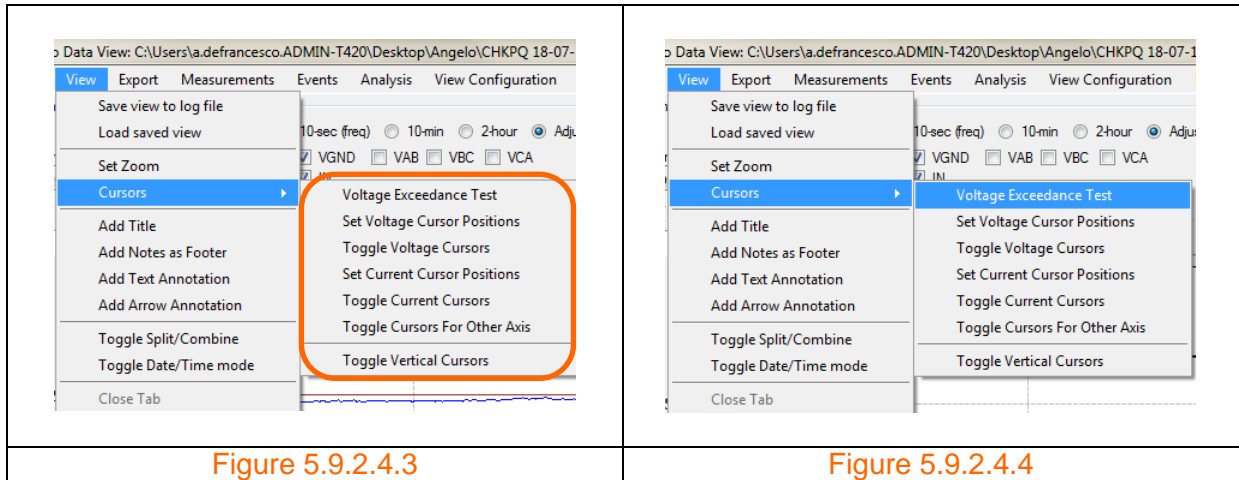

Figure 5.9.2.4.3

Figure 5.9.2.4.4

The various cursors are illustrated below.

Voltage Exceedance Test

Step 1: Click the 'Voltage Exceedance Test' button as shown in figure 5.9.2.4.4. An input box appears as shown in figure 5.9.2.4.5 showing a default nominal voltage value which the user is able to change.

Step 2: Enter the desired value and click 'OK'. In this example the value is set to 230V. An input box appears as shown in figure 5.9.2.4.6 showing a default percentage value which the user is able to change. Enter the desired value and click 'OK'. In this example the value is set to 1 percent.

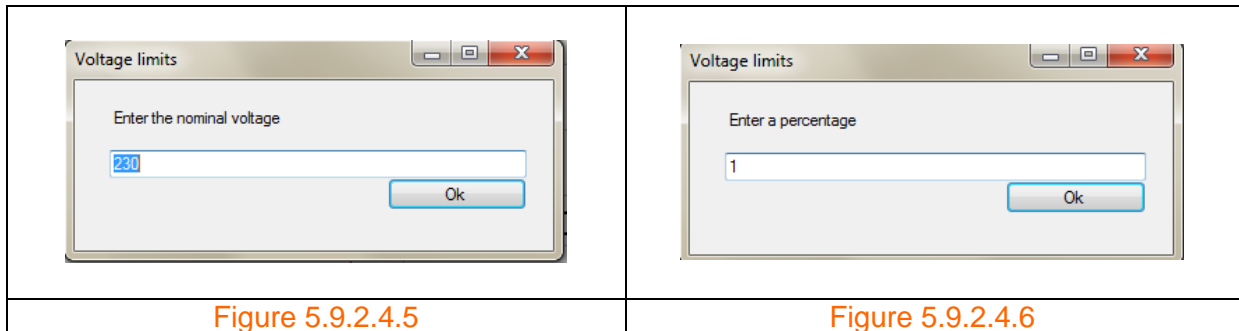
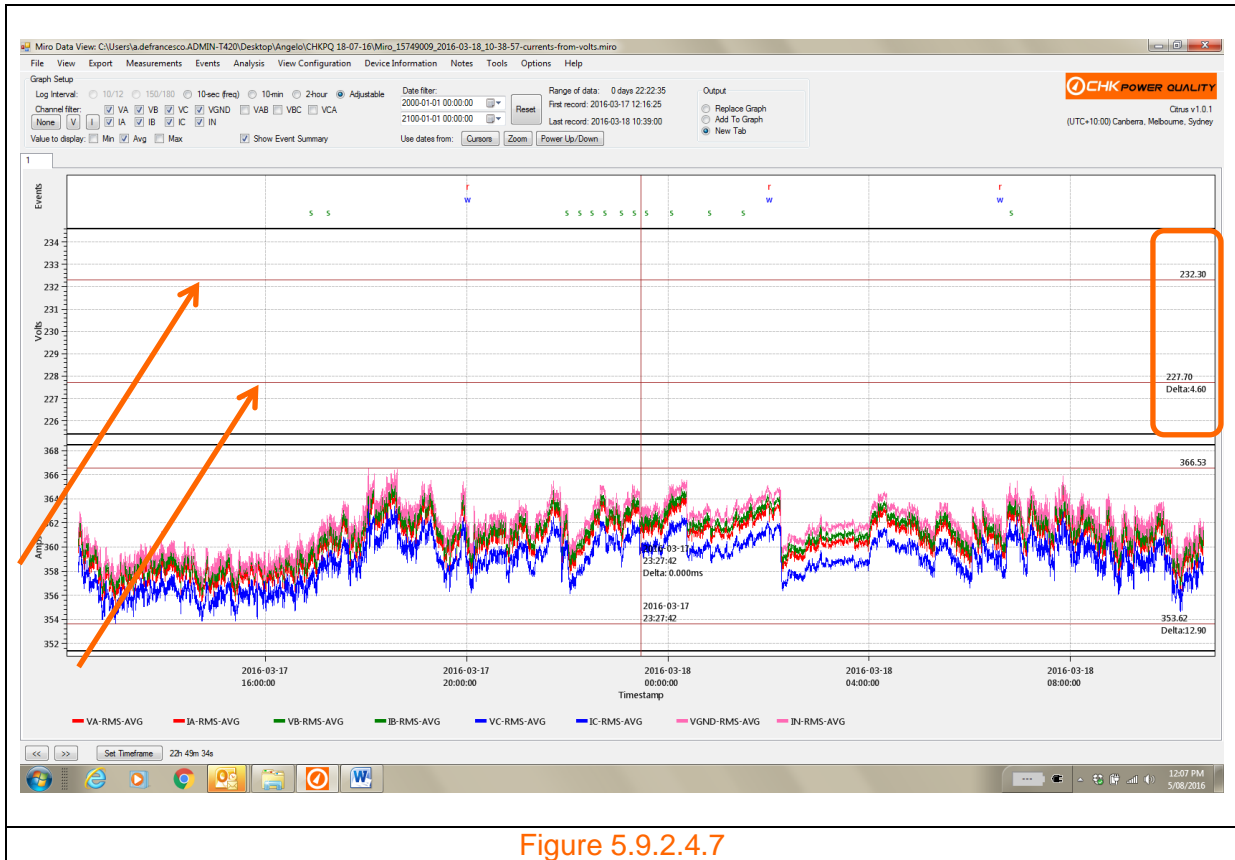

Figure 5.9.2.4.5

Figure 5.9.2.4.6

The upper and lower limit voltage cursors are now displayed in figure 5.9.2.4.7 (as pointed to by arrows) and set at 1% above (232.30V) and below (227.70V) the nominal value. The 'Delta' is the difference of the two values and equal to 4.60V.



Set Voltage Cursor Positions

Step 1: Click the 'Set Voltage Cursor Positions' button as shown in figure 5.9.2.4.8. An input box appears as shown in figure 5.9.2.4.9 showing a default upper limit voltage value which the user is able to change.

The input box also shows a default upper limit, in this case 253.000, which is set to the configured IEC Swell threshold. Refer to the message box shown in figure 5.9.2.4.10 which appears when the question mark box is clicked.

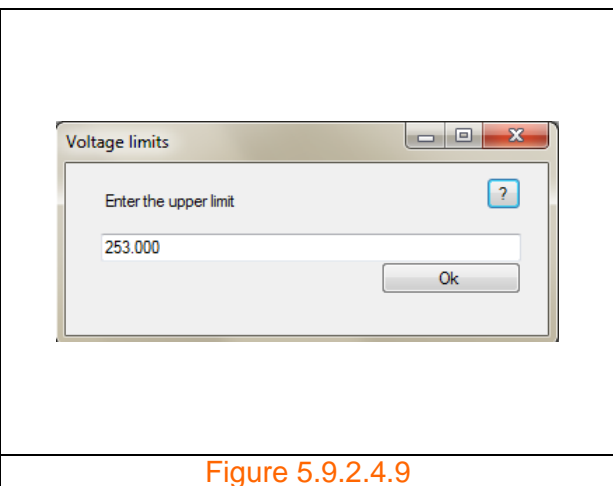
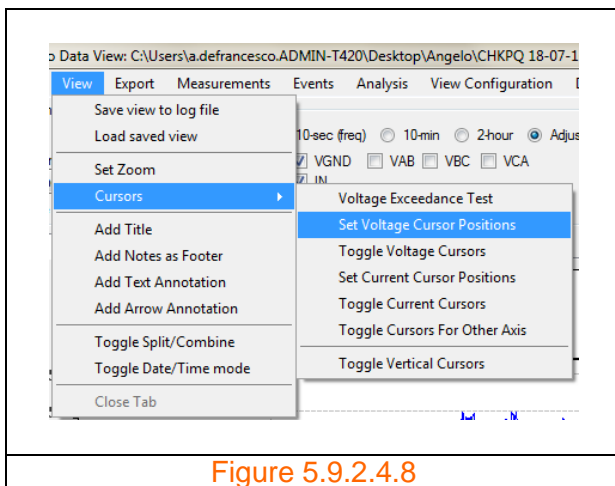

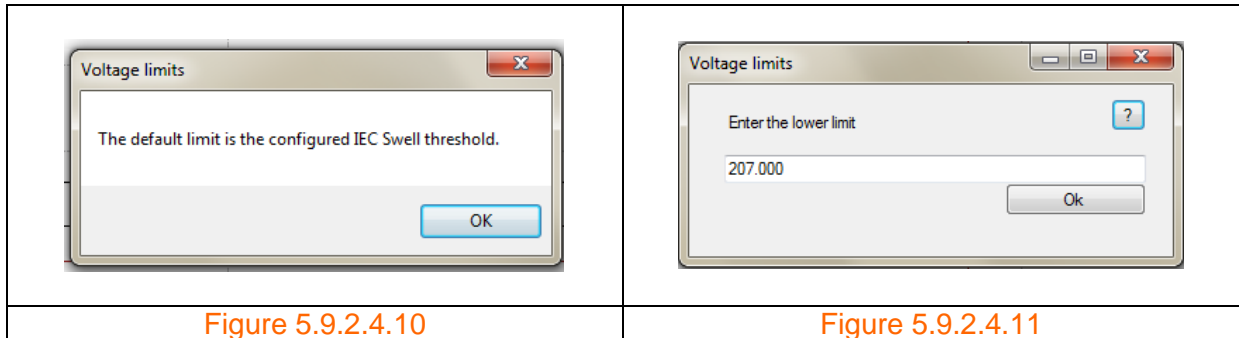

Step 2: Enter the desired value and click the 'OK' button. An input box appears as shown in figure 5.9.2.4.11 showing a default lower limit voltage value which the user is able to change.

The input box also shows a default lower limit, in this case 207.000, which is set to the configured IEC Swell threshold. Refer to the message box shown in figure 5.9.2.4.10 which appears when the question mark box is clicked.

The upper and lower limit voltage cursors are now displayed in figure 5.9.2.4.12 (as pointed to by arrows) and set at 10% above (253.00V) and below (207.00V) the nominal value. The 'Delta' is the difference of the two values and equal to 46V.

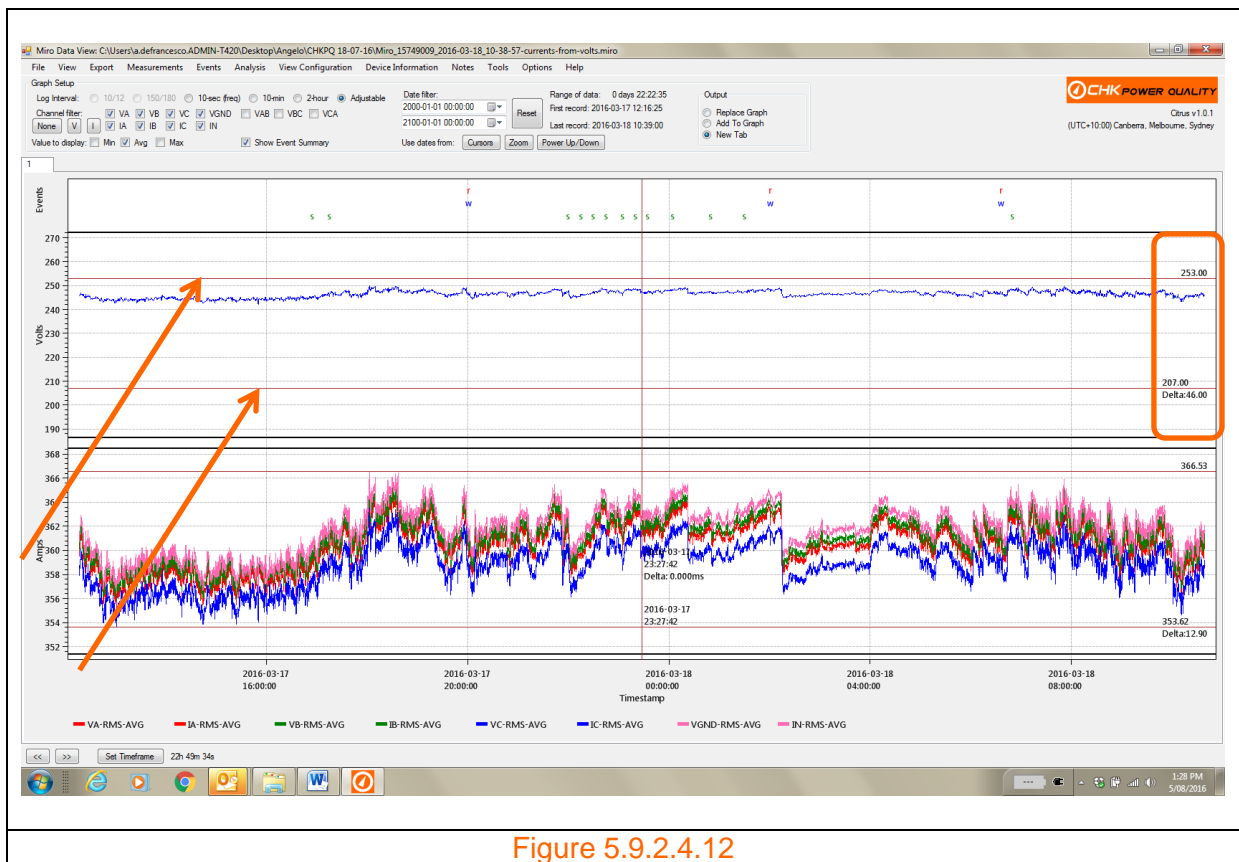

Figure 5.9.2.4.12

Change voltage cursor position

Click and drag the cursor up or down to change its position.

Toggle voltage cursors

Step 1: Click the 'Toggle Voltage Cursors' button as shown in figure 5.9.2.4.13. The voltage cursors disappear.

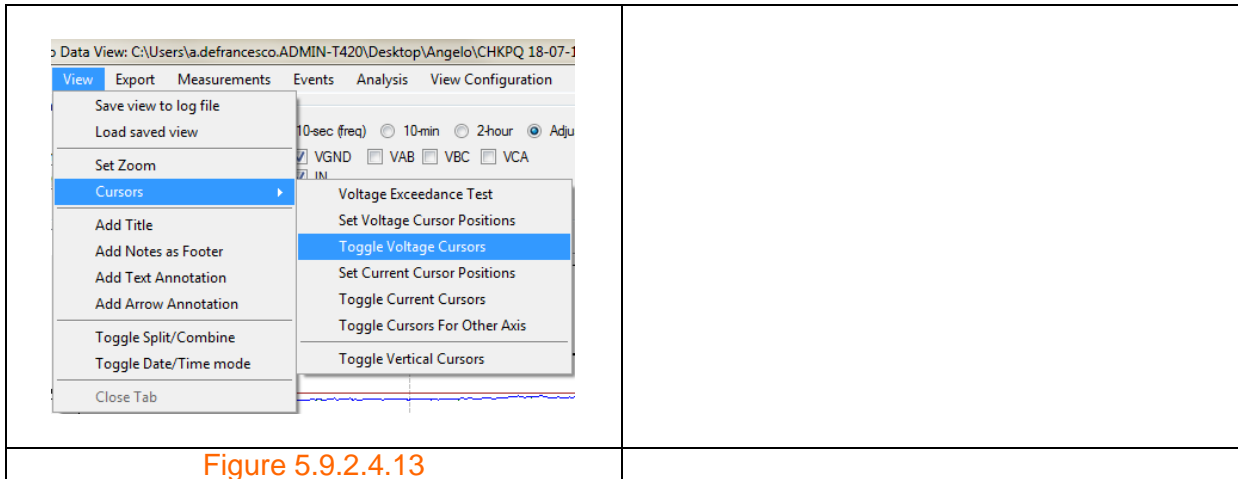

Figure 5.9.2.4.13

Step 2: Click the 'Toggle Voltage Cursors' button again. The voltage cursors reappear.

Set current cursor positions

Step 1: Click the 'Set Current Cursor Positions' button as shown in figure 5.9.2.4.14. An input box appears as shown in figure 5.9.2.4.15 showing a default value of 359.929, which is set to the value in the middle of the graph.

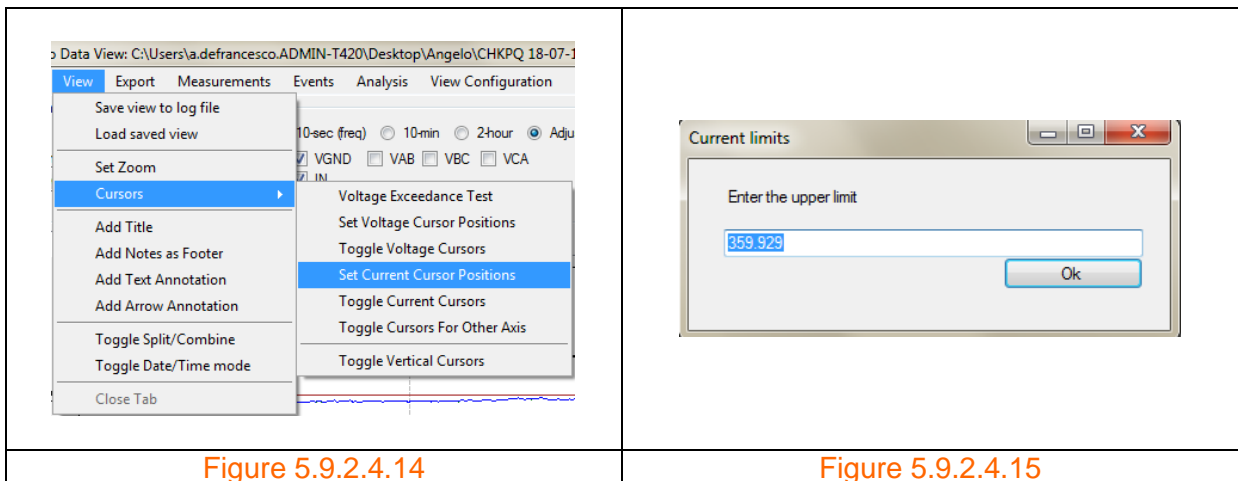

Figure 5.9.2.4.14

Figure 5.9.2.4.15

Step 2: Enter the desired value and click the 'OK' button. An input box appears as shown in figure 5.9.2.4.16 showing a default value of 359.929, which is set to the value in the middle of the graph.

Step 3: Enter the desired value and click the 'Ok' button. The cursors are now set to the new positions. The upper and lower limit current cursors are now displayed in figure 5.9.2.4.17 (as pointed to by arrows) and set to 367A and 353A. The 'Delta' is the difference of the two values and equal to 14A.

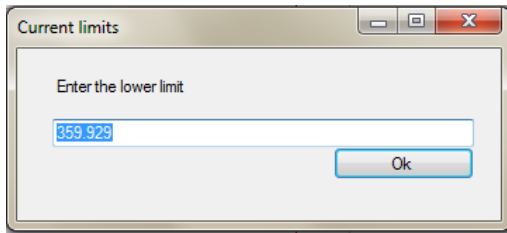

Figure 5.9.2.4.16

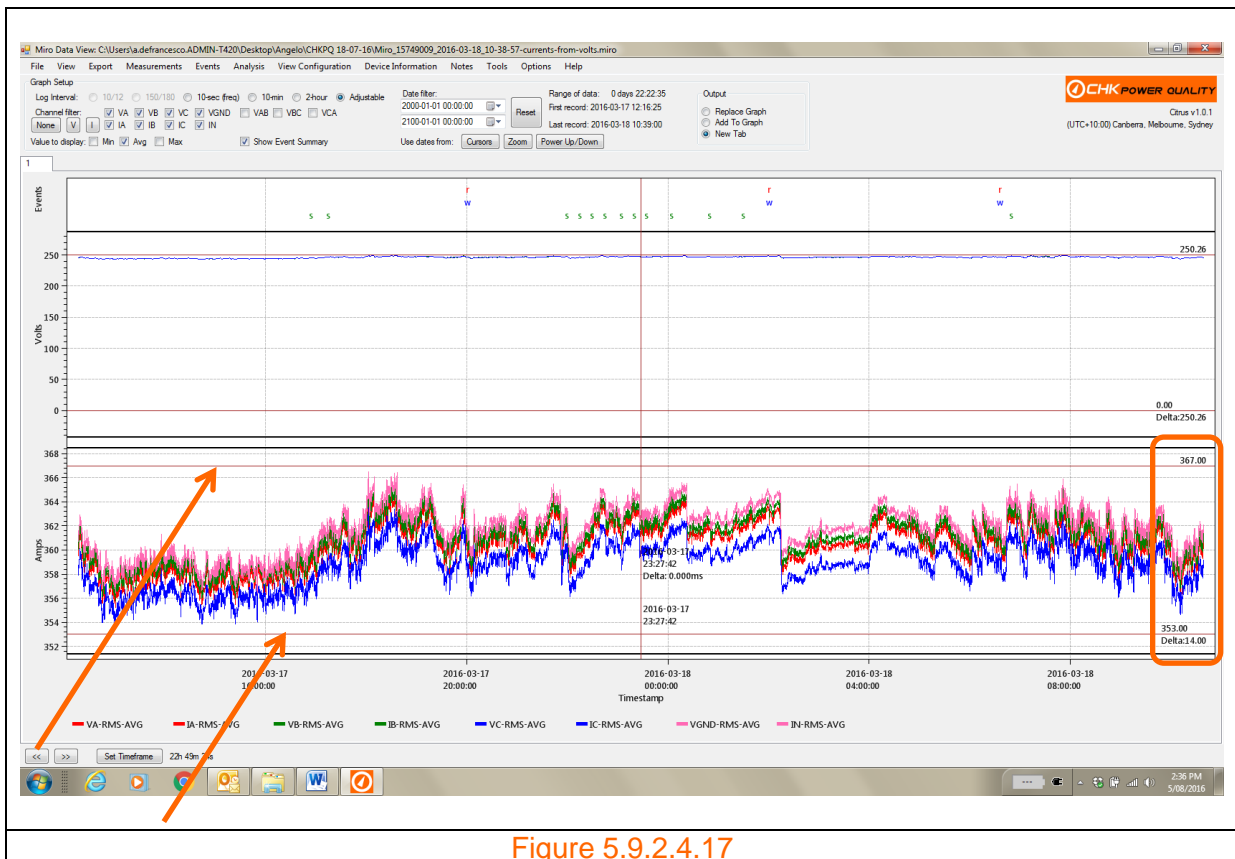

Figure 5.9.2.4.17

Change current cursor position

Click and drag the cursor up or down to change its position.

Toggle current cursors

Step 1: Click the 'Toggle Current Cursors' button as shown in figure 5.9.2.4.18. The current cursors disappear.

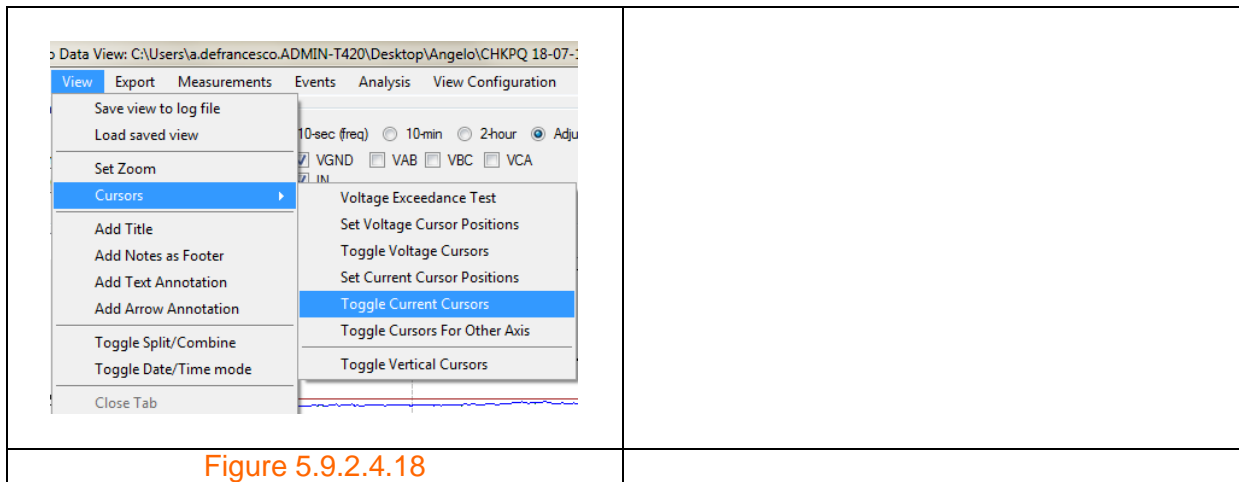

Step 2: Click the 'Toggle Current Cursors' button again. The current cursors reappear.

Toggle cursors for other axis

Step 1: Click the 'Toggle Cursors For Other Axis' button as shown in figure 5.9.2.4.19. A message box as shown in figure 5.9.2.4.20 appears if no mother axis available.

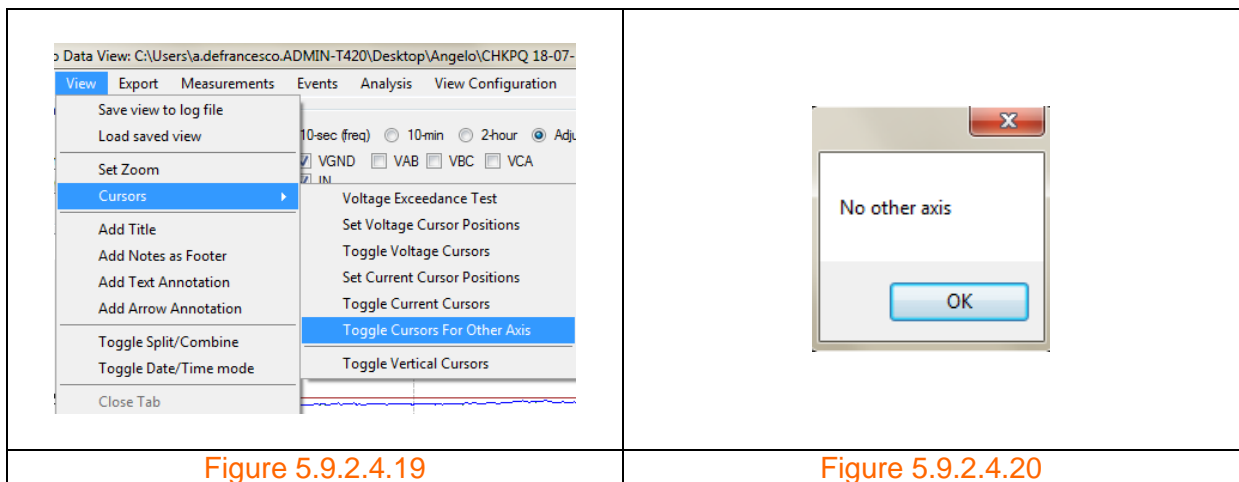

Figure 5.9.2.4.21 includes a frequency plot with its own set of cursors.

Step 2: Click the 'Toggle Cursors For Other Axis' button as shown in figure 5.9.2.4.19. The cursors for the frequency plot disappear.

Step 3: Click the 'Toggle Cursors For Other Axis' button again. The cursors reappear.

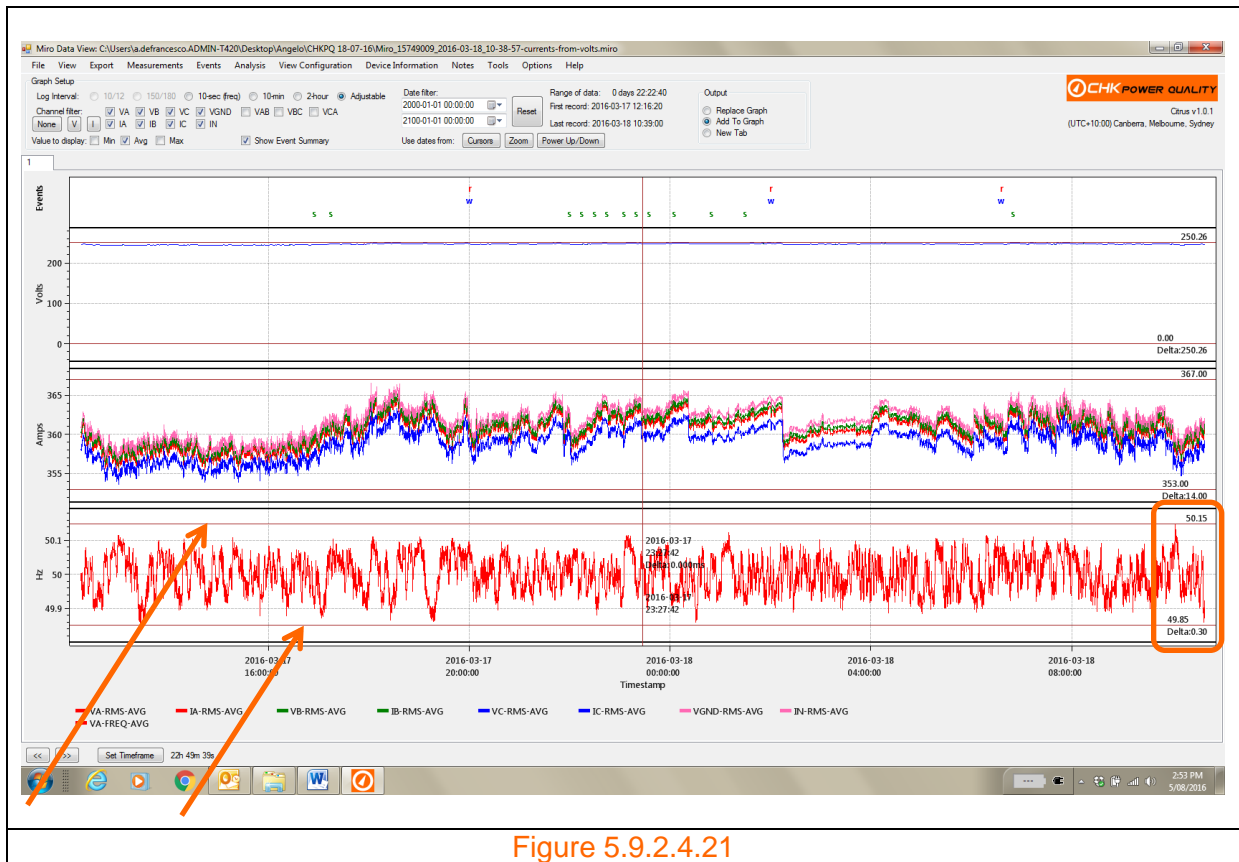

Figure 5.9.2.4.21

Toggle vertical cursors

Step 1: Click the 'Toggle Vertical Cursors' button as shown in figure 5.9.2.4.22. The vertical cursors disappear.

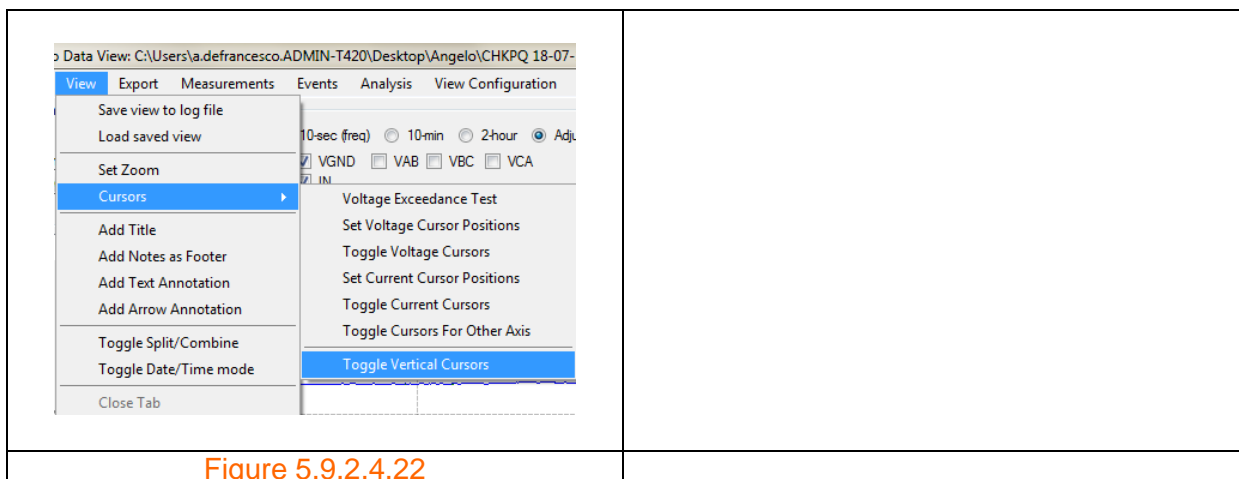

Figure 5.9.2.4.22

Step 2: Click the 'Toggle Vertical Cursors' button again. The cursors reappear.

5.9.2.5 Add title

The user is able to insert a title on the graph.

Step 1: Click the 'View' menu shown in figure 5.9.2.3.1. A drop down box appears as shown in figure 5.9.2.3.2.



Step 2: Hover and click on 'Add Title'. A message input box appears as shown in figure 5.9.2.3.3 asking to type in a title.

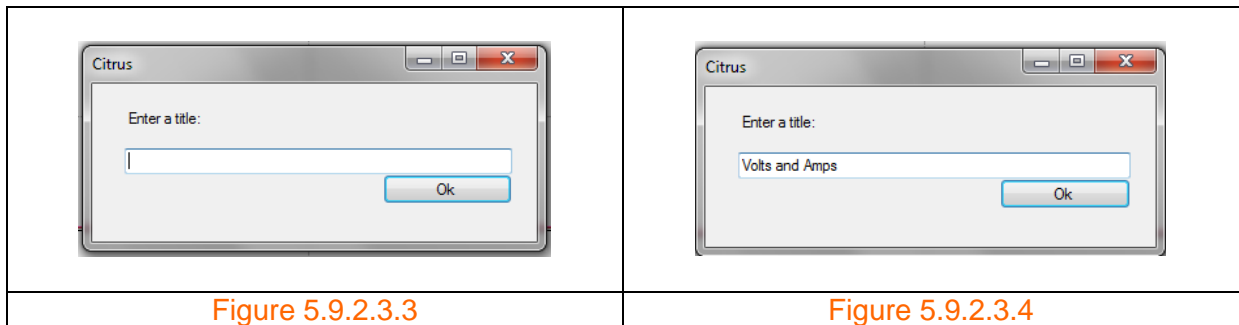

Step 3: Type in a title and click 'OK'. In this case the title entered is 'Volts and Amps' as shown in figure 5.9.2.3.4. The graph in figure 5.8.2.3.5 is now updated with the title 'Volts and Amps'.

Removing a title

To remove a title from an existing graph, follow steps 1 and 2. Leave blank for step 3. The title will be removed from the graph.

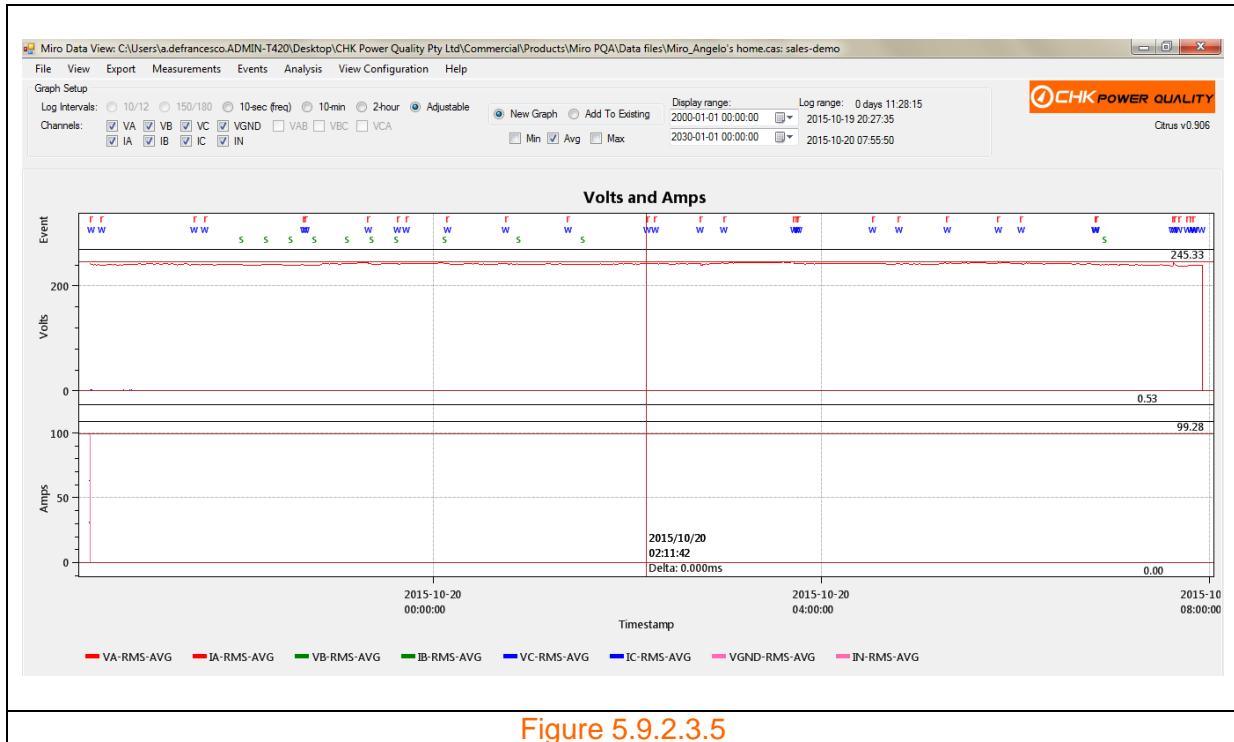

5.9.2.6 Add notes as footer

This feature assumes that notes have been added and that the text for the notes is 'Profile of a Distribution Transformer'. Refer to section on 'Notes'.

Step 1: Click the 'View' menu shown in figure 5.9.2.6.1. A drop down box appears as shown in figure 5.9.2.6.2.

Step 2: Hover and click on 'Add Notes as Footer'. The text is now appended to the graph as shown in figure 5.9.2.6.3. Clicking the 'Add Notes as Footer' item again will remove the text from the graph.

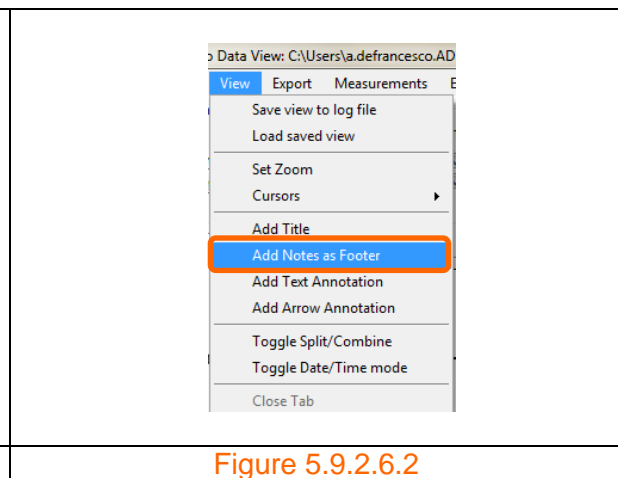
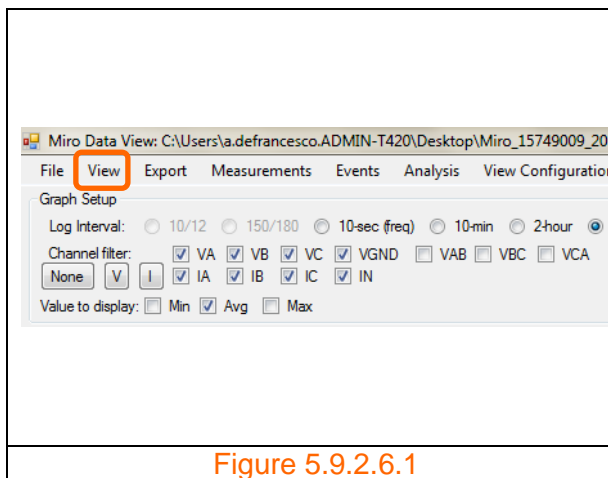

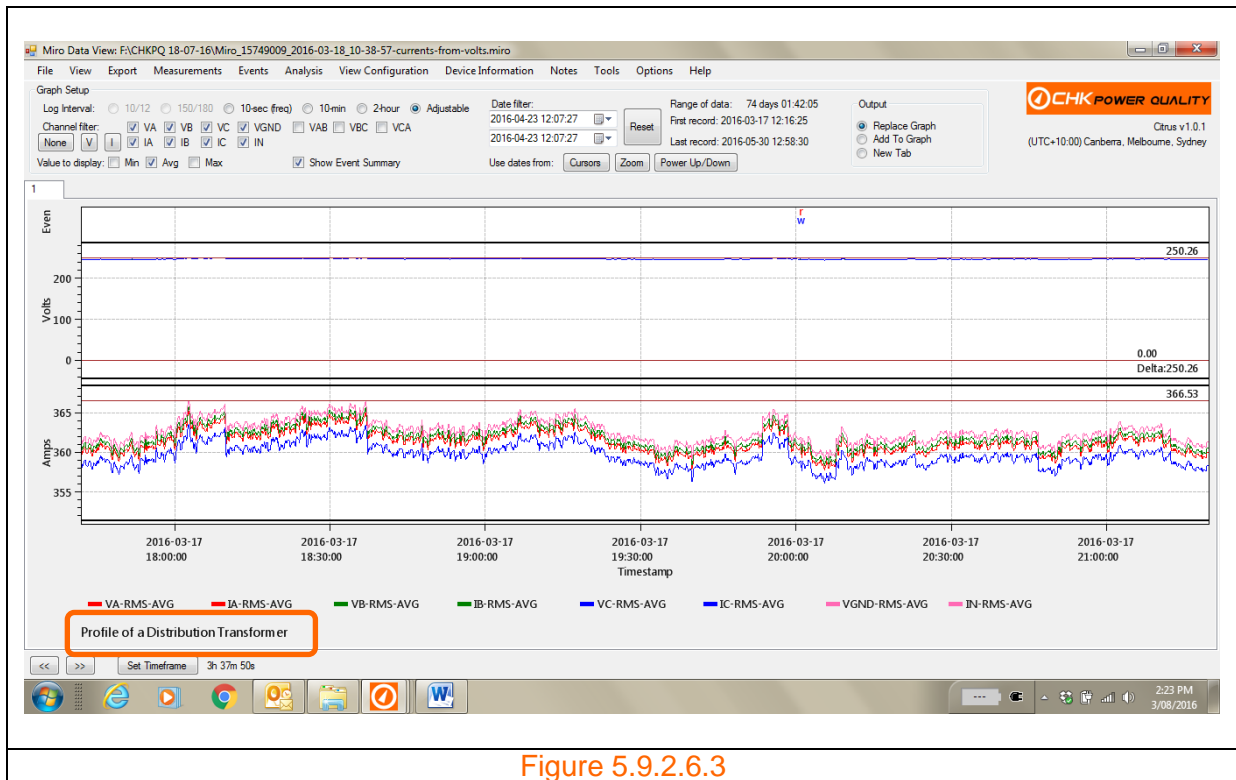

5.9.2.7 Add text annotation

The user is able to insert text onto the graph.

Step 1: Click the 'View' menu shown in figure 5.9.2.7.1. A drop down box appears as shown in figure 5.9.2.7.2.

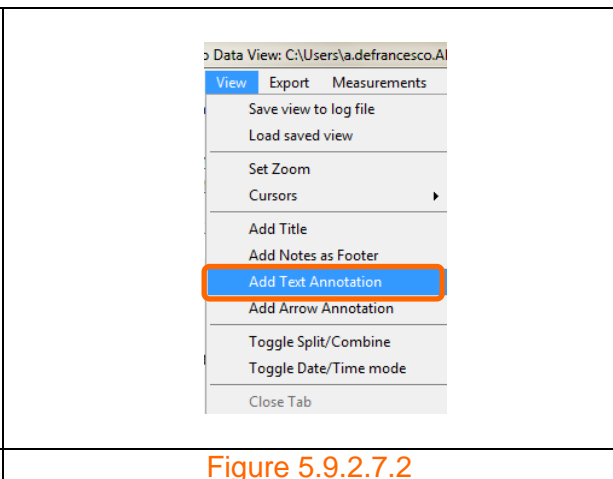
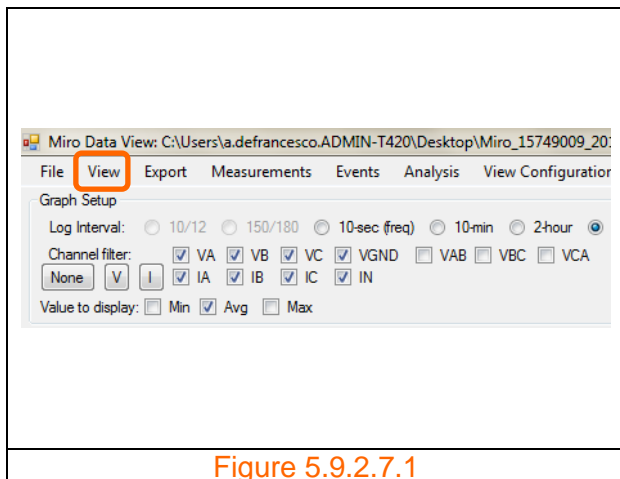

Step 2: Hover and click on 'Add Text Annotation'. A message input box appears as shown in figure 5.9.2.7.3 asking the user to select 'VOLTS' or 'AMPS'.

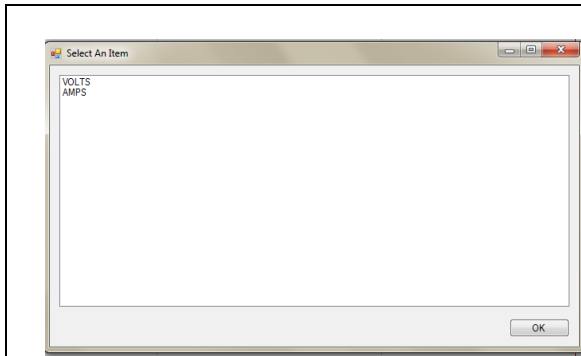

Figure 5.9.2.7.3

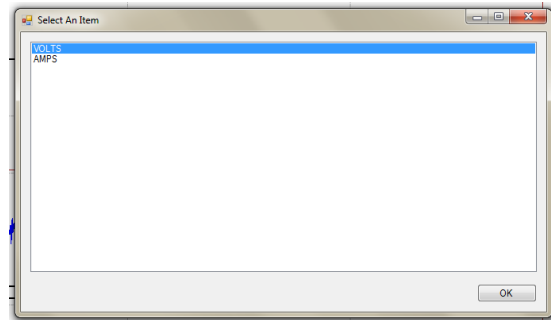

Figure 5.9.2.7.4

Step 3: For example select 'VOLTS' click 'OK' as shown in figure 5.9.2.7.4. The input box as shown in figure 5.9.2.7.5 appears.

Step 4: Type in the desired comment as shown in figure 5.9.2.7.6 and click 'OK'.

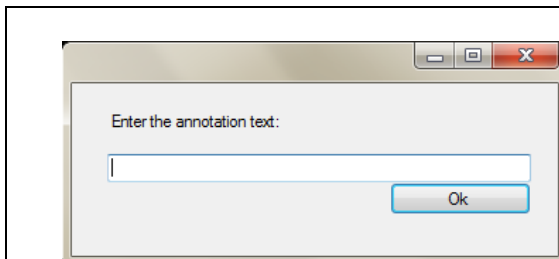

Figure 5.9.2.7.5

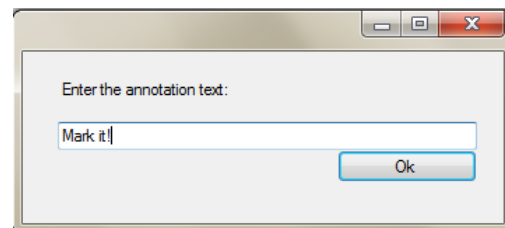

Figure 5.9.2.7.6

The comment will now appear in a text box as shown in figure 5.9.2.7.7. The text can be moved anywhere on the voltage graph by hovering the mouse pointer in the text box and then holding down the left hand side button on the mouse and dragging.

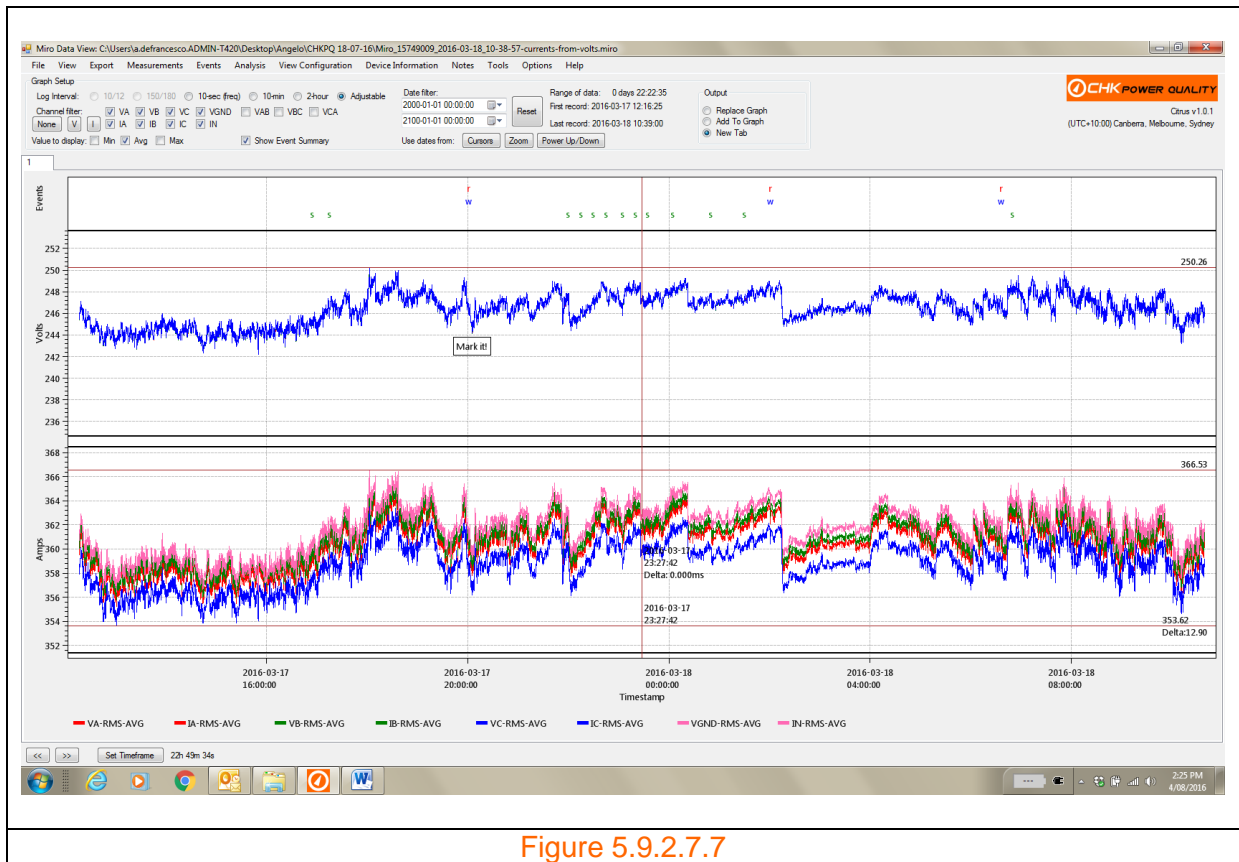

Figure 5.9.2.7.7

Hiding the text annotation

Hovering the mouse pointer in the text box and then holding down the left hand side button on the mouse drag the box away from the graph area and release the mouse button.

5.9.2.8 Add arrow annotation

The user is able to insert an arrow onto the graph.

Step 1: Click the 'View' menu shown in figure 5.9.2.8.1. A drop down box appears as shown in figure 5.9.2.8.2.

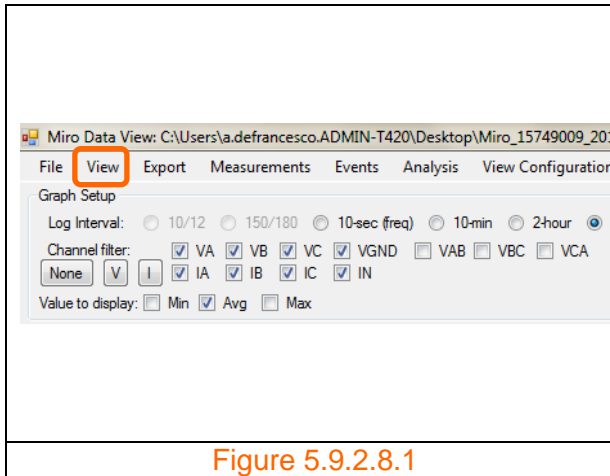

Figure 5.9.2.8.1

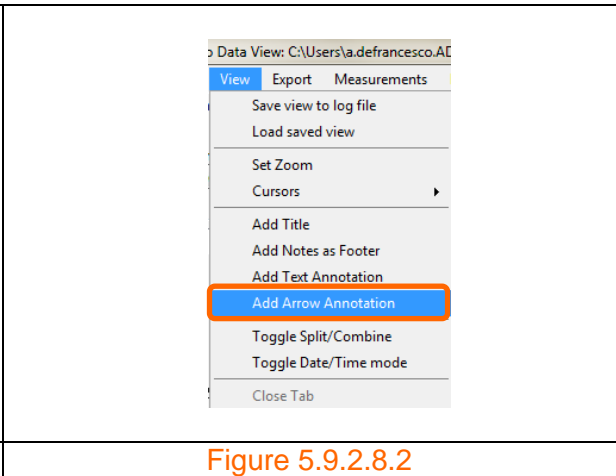

Figure 5.9.2.8.2

Step 2: Hover and click on 'Add Text Annotation'. A message input box appears as shown in figure 5.9.2.8.3 asking the user to select 'VOLTS' or 'AMPS'.

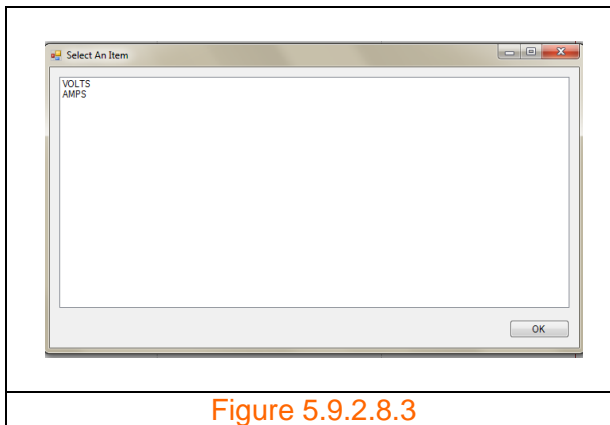

Figure 5.9.2.8.3

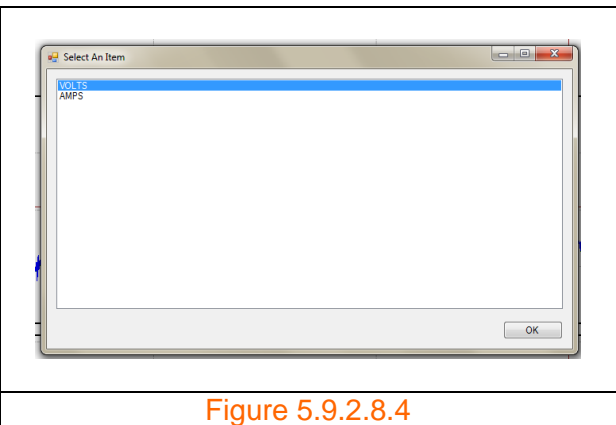

Figure 5.9.2.8.4

Step 3: For example select 'VOLTS' click 'OK' as shown in figure 5.9.2.8.4. The input box as shown in figure 5.9.2.8.5 appears.

Step 4: Type in the desired arrow length as shown in figure 5.9.2.8.6 and click 'OK'.

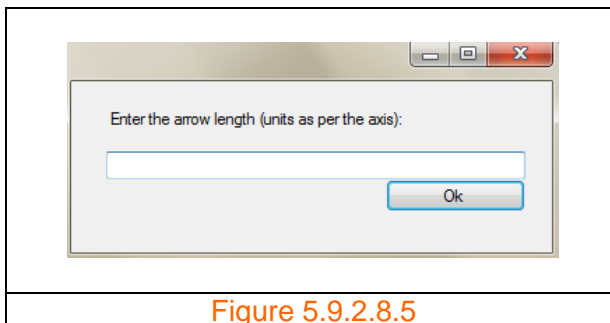

Figure 5.9.2.8.5

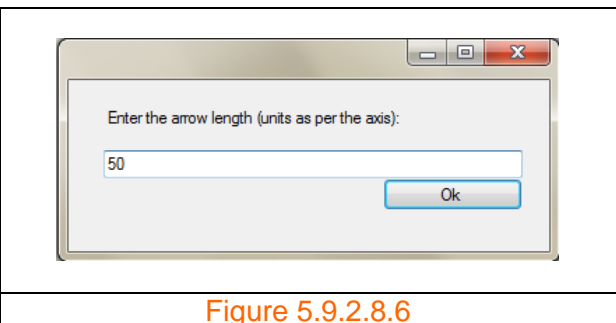

Figure 5.9.2.8.6

The arrow will now appear on the voltage graph as shown in figure 5.9.2.8.7.

The length and direction of the arrow can be changed by: hovering the mouse pointer onto the arrow head; left clicking and holding down the left hand side button on the mouse; and dragging the head anywhere on the graph. This is shown in figure 5.9.2.8.8.

The whole arrow can be moved by: hovering the mouse pointer anywhere onto the arrow; left clicking and holding down the left hand side button on the mouse; and dragging the arrow anywhere on the graph. This is shown in figure 5.9.2.8.8.

Hiding the arrow annotation

Hovering the mouse pointer onto the arrow and then holding down the left hand side button on the mouse drag the arrow away from the graph area and release the mouse button.

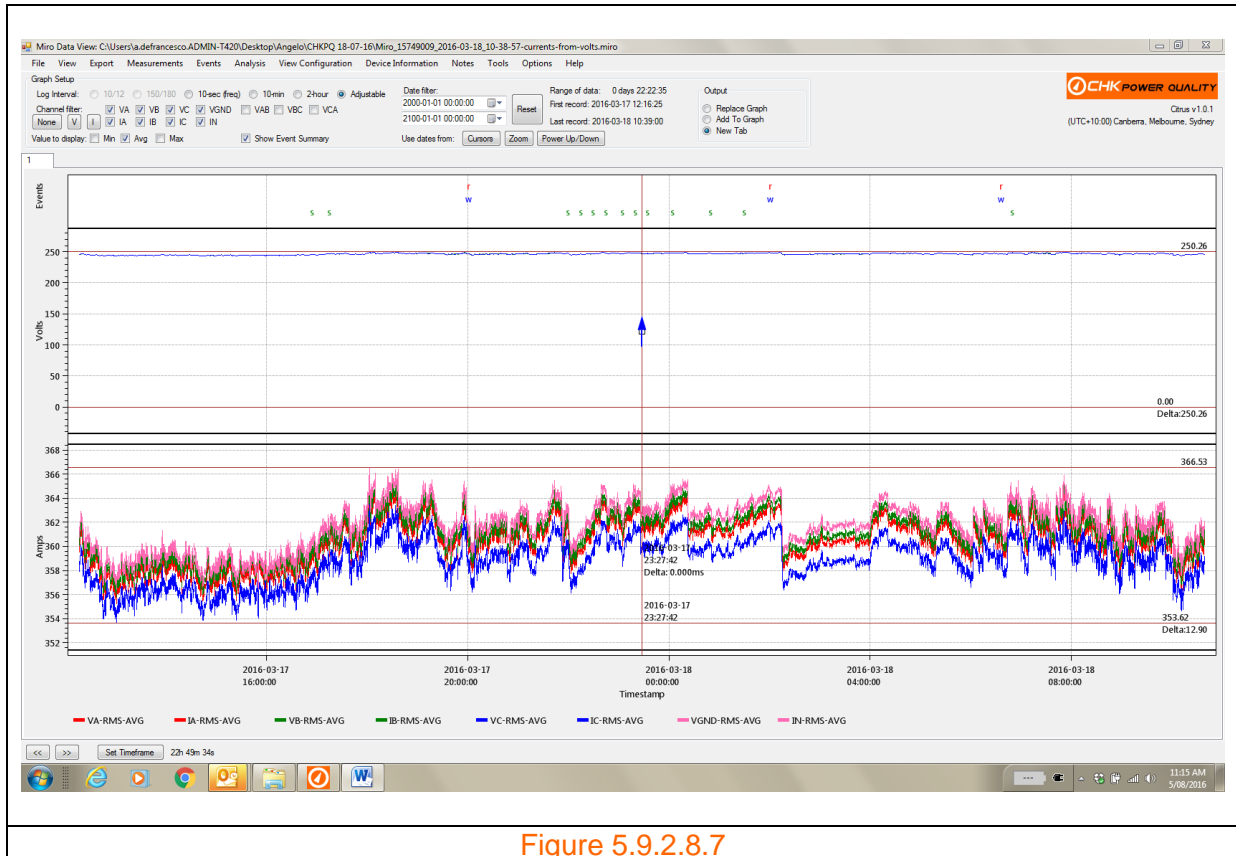

Figure 5.9.2.8.7

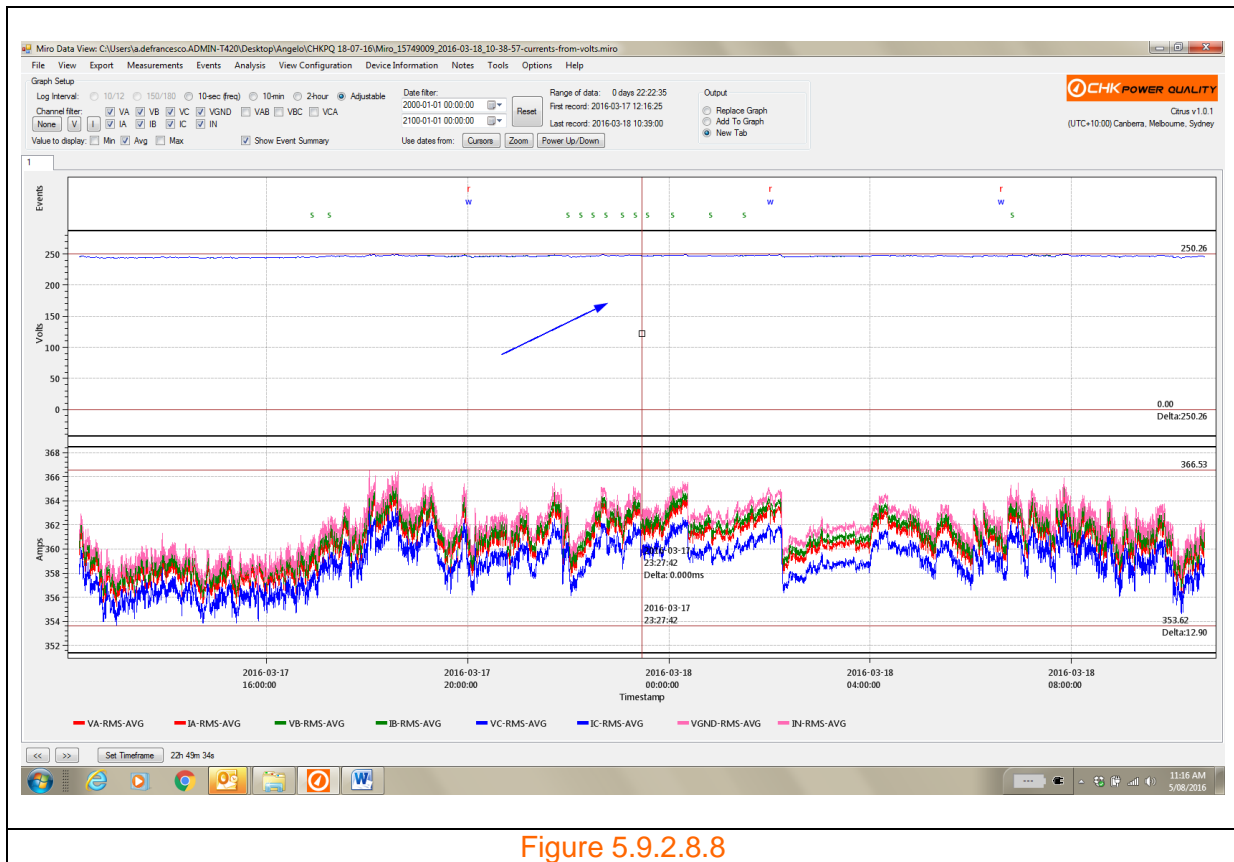

Figure 5.9.2.8.8

5.9.2.9 Toggle split/combine

The file viewer automatically graphs the file data to display Volts/Amps as two separate graphs, one for voltage and the other for current as shown in figure 5.9.2.1.1.

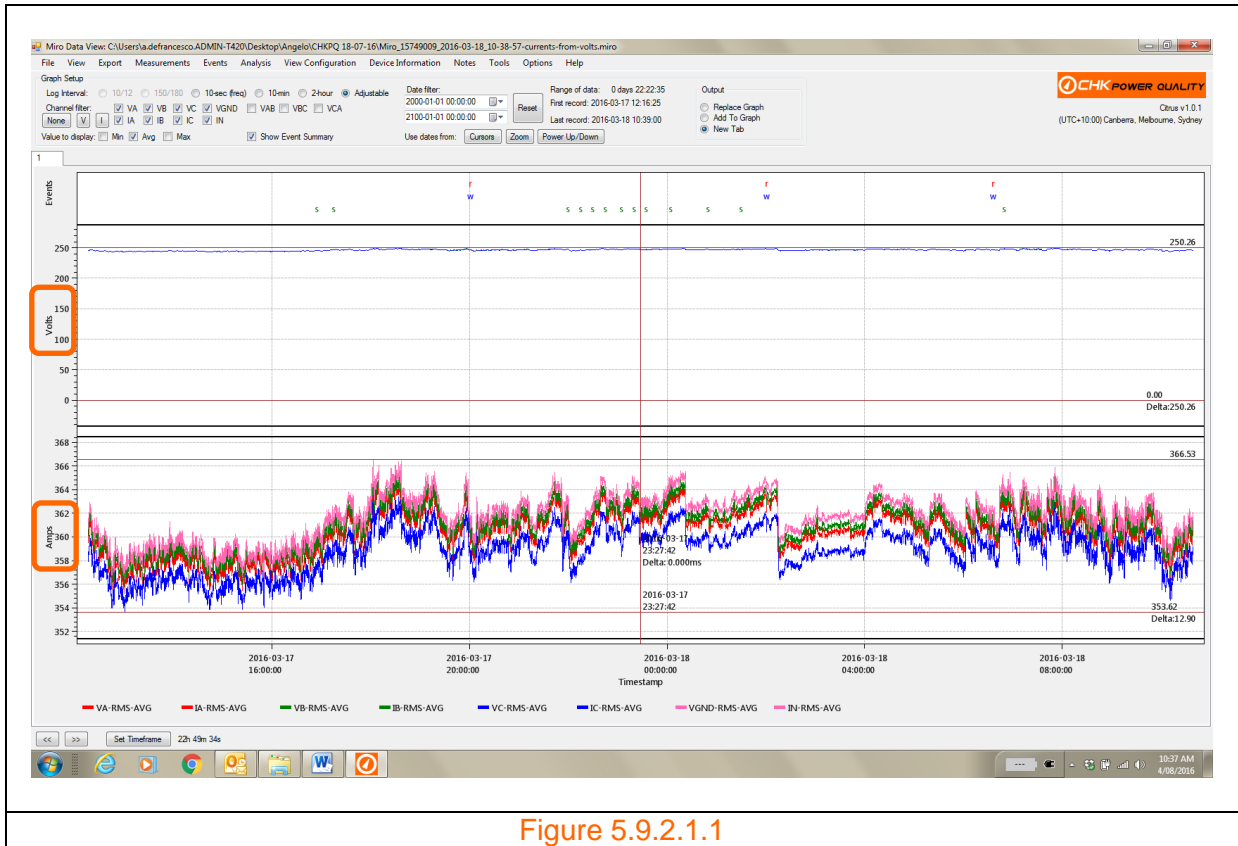

Figure 5.9.2.1.1

The user is able to display the voltage and current onto a single graph.

Step 1: Click the 'View' menu shown in figure 5.9.2.1.2. A drop down box appears as shown in figure 5.9.2.1.3.

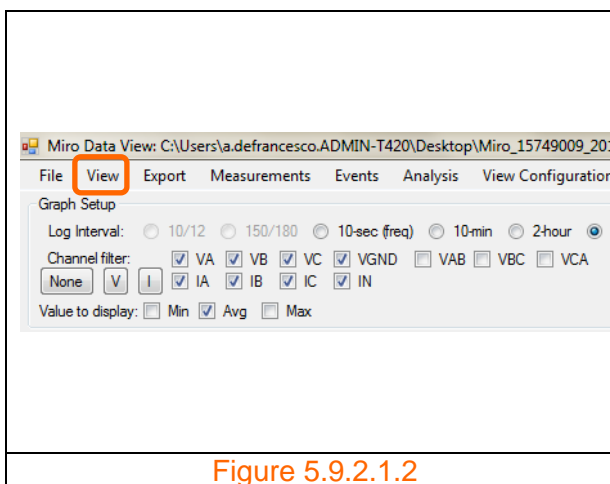

Figure 5.9.2.1.2

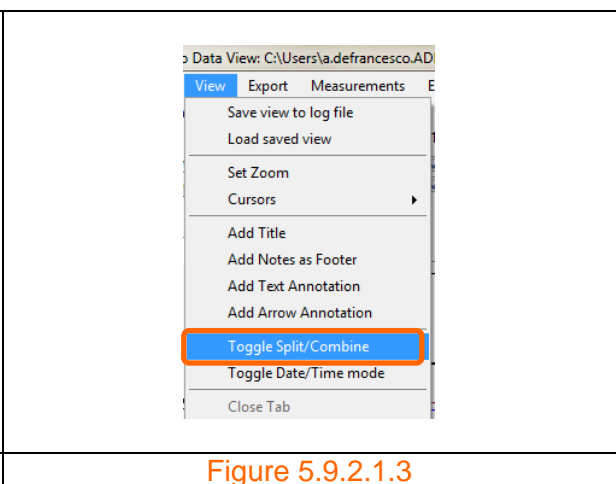

Figure 5.9.2.1.3

Step 2: Hover and click on 'Toggle Split/Combine'. The screen view automatically alters the graphs as shown in figure 5.9.2.1.4.

Note that the axis for the current now appears at the right hand side. Also, CITRUS automatically disables the split feature if graphing only volts or current.

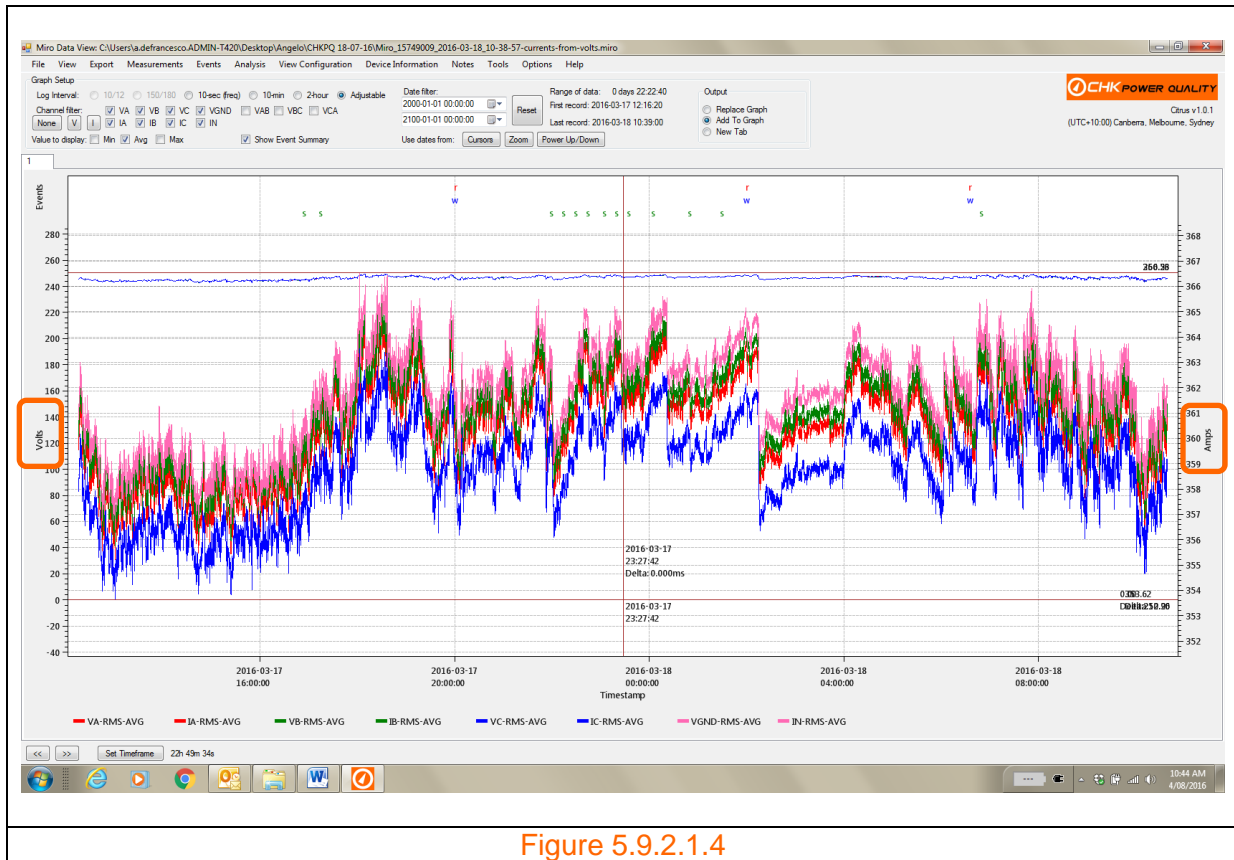

Figure 5.9.2.1.4

The combining and splitting of the charts is applicable to any set of graphed parameters and not limited only to the Volts/Amp display.

For example figures 5.9.2.1.5 and 5.9.2.1.6 show TRMS and frequency magnitudes graphed as split and combined graphs.

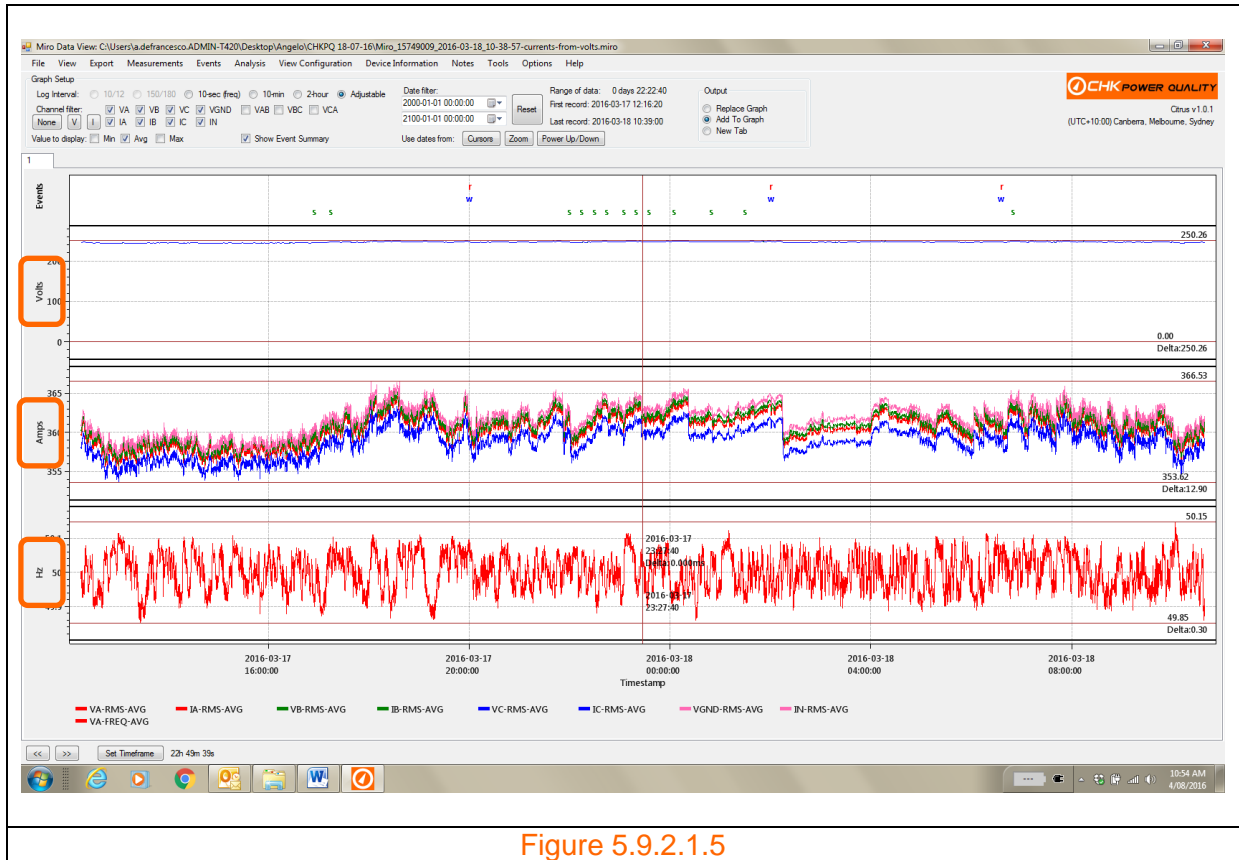

Figure 5.9.2.1.5

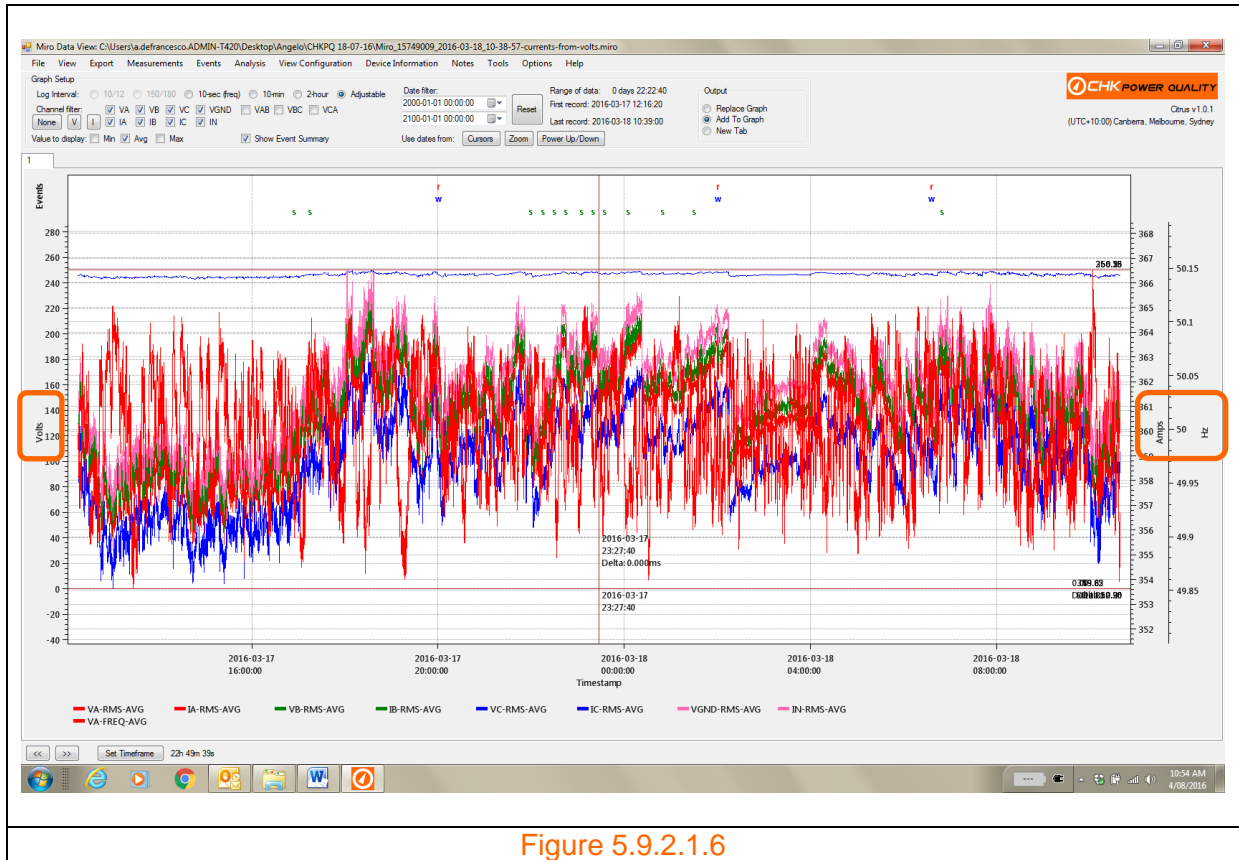

Figure 5.9.2.1.6

5.9.2.10 Toggle date /time mode

Step 1: Click the 'View' menu shown in figure 5.9.2.2.1. A drop down box appears as shown in figure 5.9.2.2.2.

Step 2: Hover and click on 'Toggle Date/Time mode'. The screen view automatically alters the time scale on the time axis as shown in figures 5.9.2.2.3 and 5.9.2.2.4. The time mode can be hourly, daily, weekly or monthly intervals.

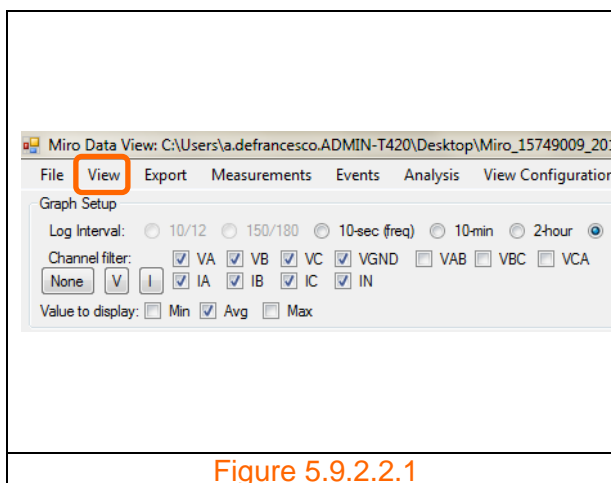

Figure 5.9.2.2.1

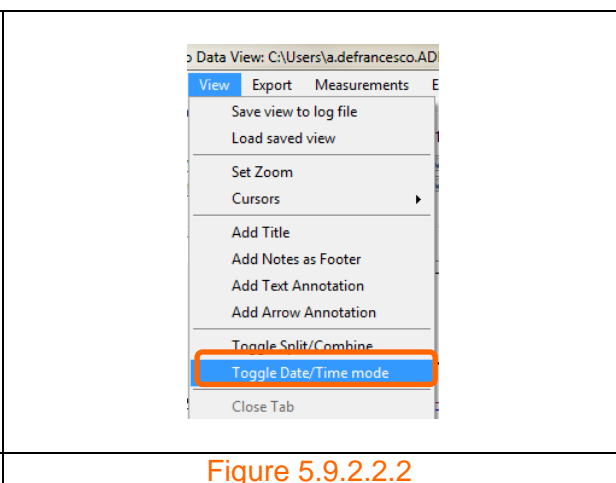

Figure 5.9.2.2.2

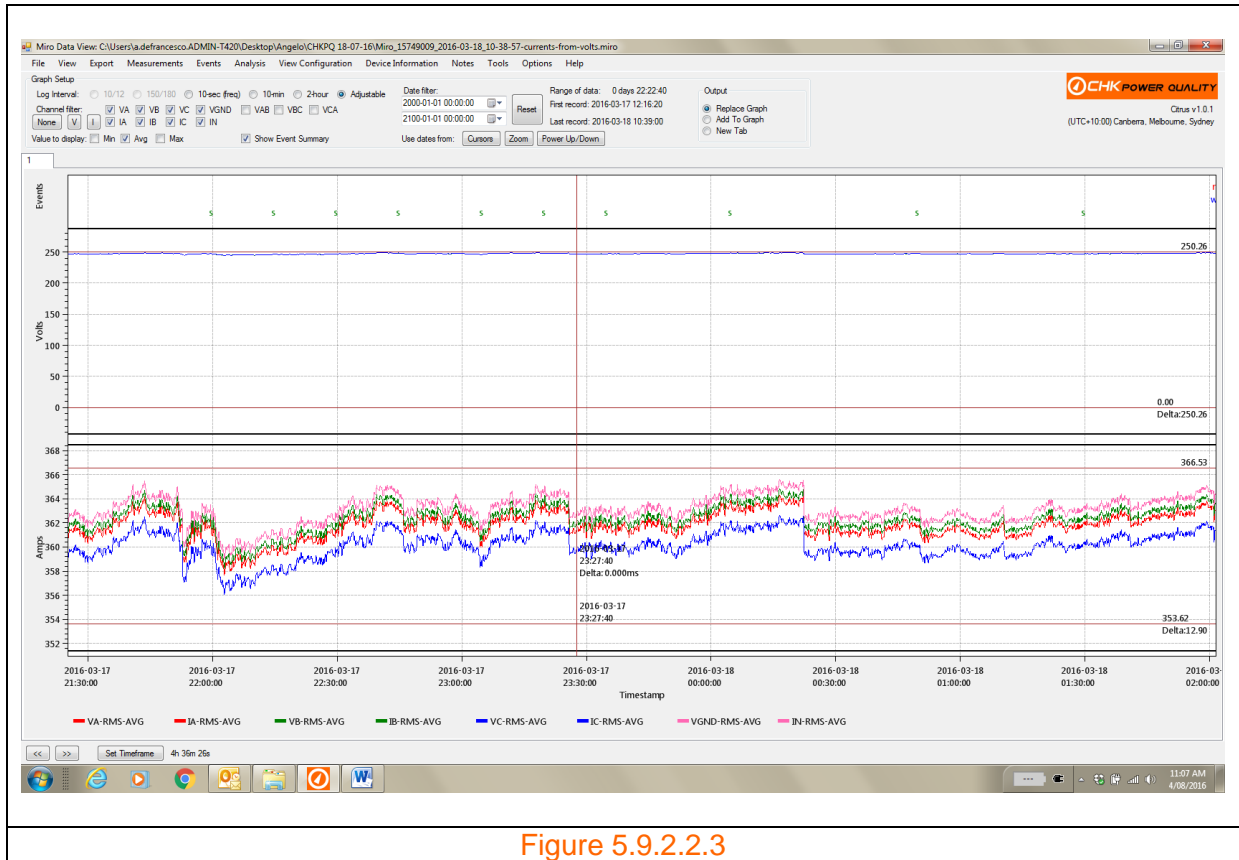

Figure 5.9.2.2.3

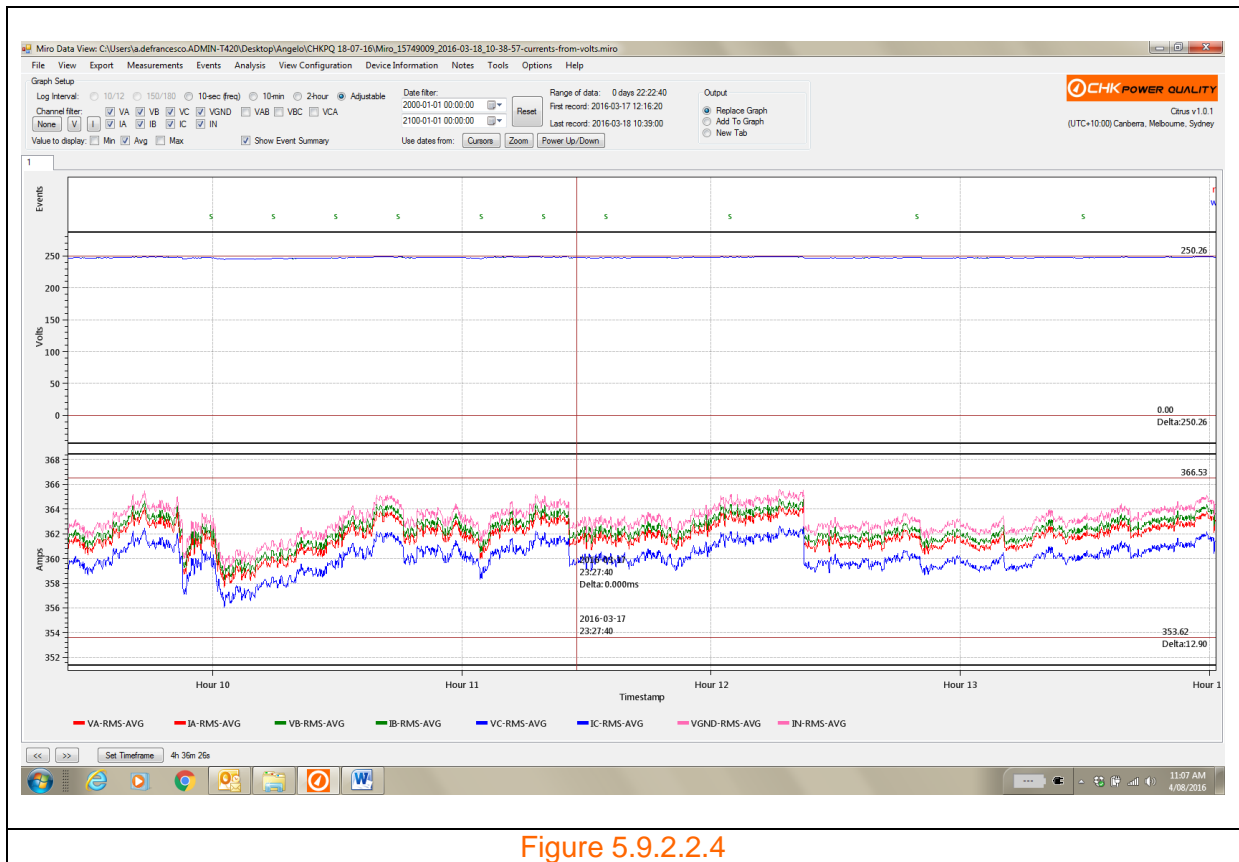

Figure 5.9.2.2.4

5.9.2.11 Close tabs

The user is able to remove tabs using the 'Close Tab' button.

Step 1: Click the 'View' menu shown in figure 5.9.2.11.1. A drop down box appears as shown in figure 5.9.2.11.2.

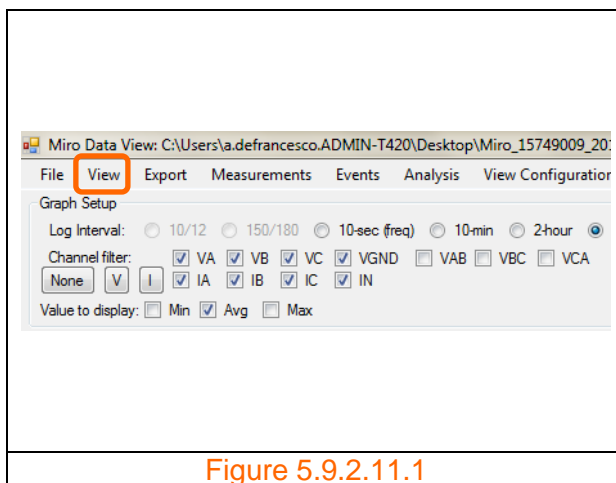

Figure 5.9.2.11.1

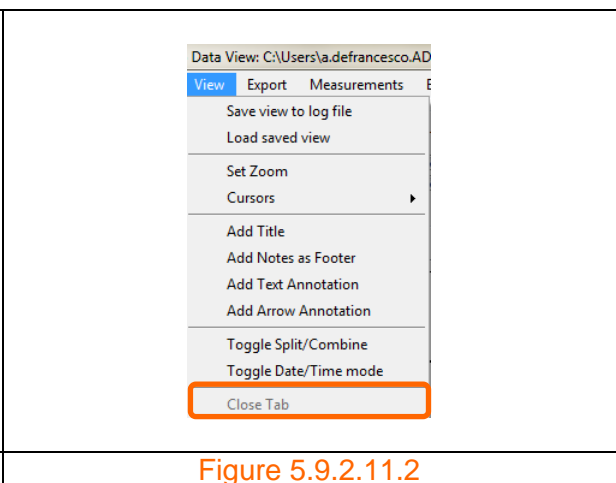
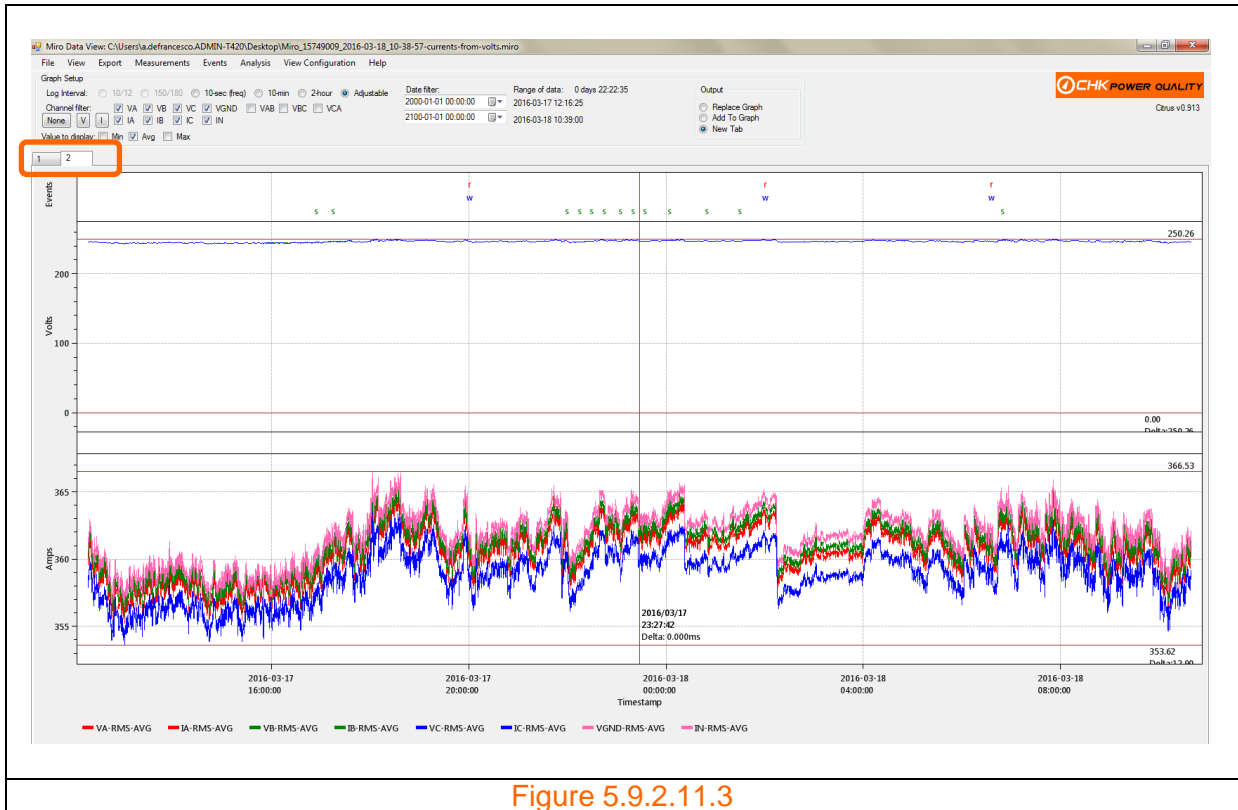
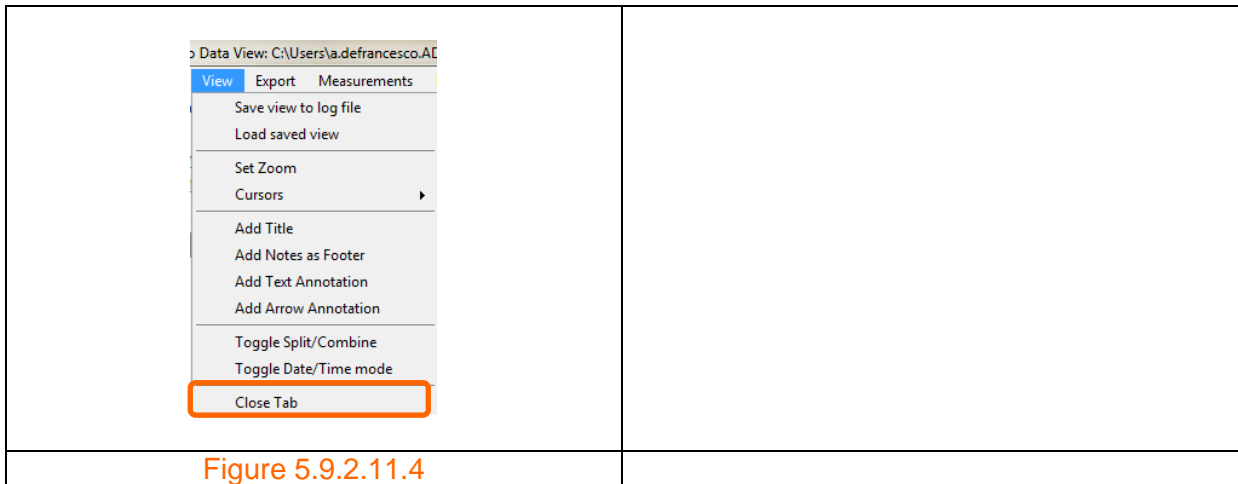

Figure 5.9.2.11.2

Note that the 'Close Tab' button is disabled. It is only enabled when two or more tabs are available. Note that two tabs are available in figure 5.9.2.11.3.



Step 2: Click the 'View' menu shown in figure 5.9.2.11.1 again. A drop down box appears as shown in figure 5.9.2.11.4. Note that the 'Close Tab' button is now active.



Step 3: Click on the 'Close Tab' button. The active tab is now removed, as shown in figure 5.9.2.11.5.

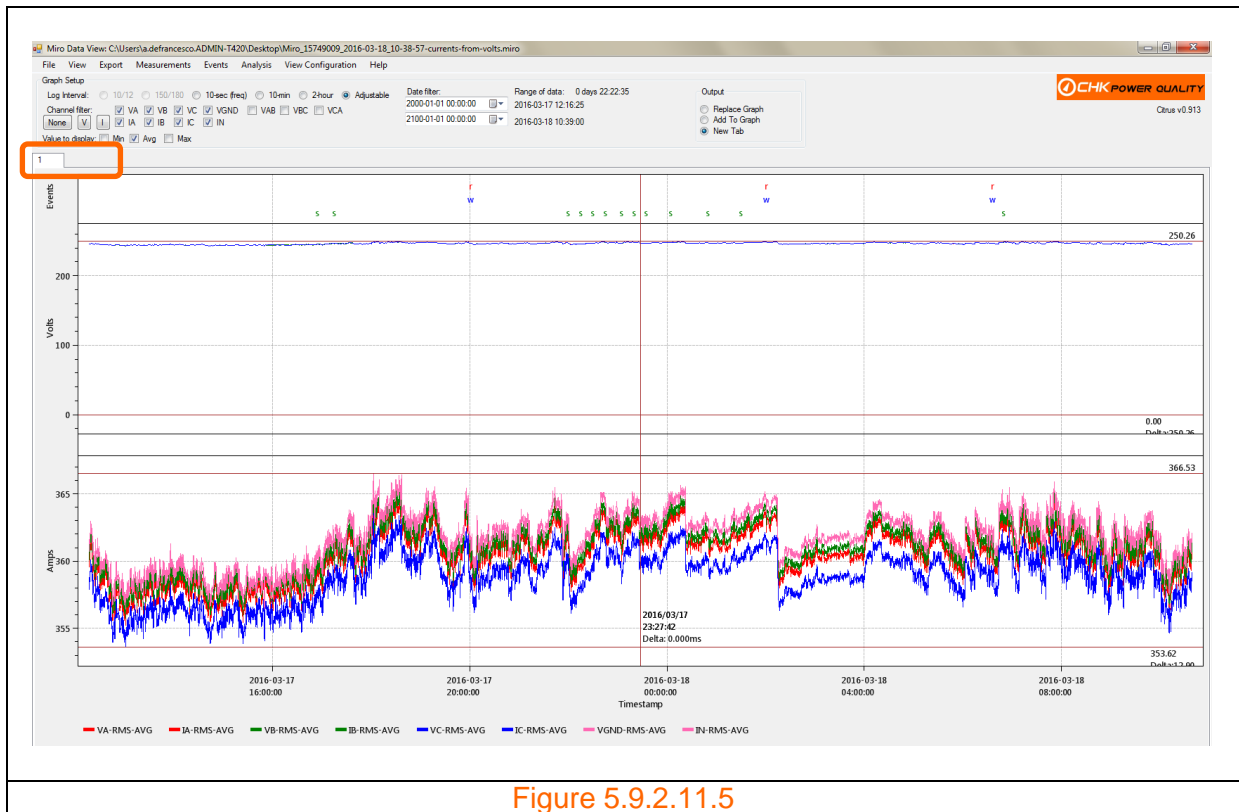

5.9.3 Export

5.9.3.1 Print

The user is able to print the graphs using the 'Print' function.

Step 1: Click the 'Print' button shown in figure 5.9.3.1.1. The printer setup form appears as shown in figure 5.9.3.1.2.

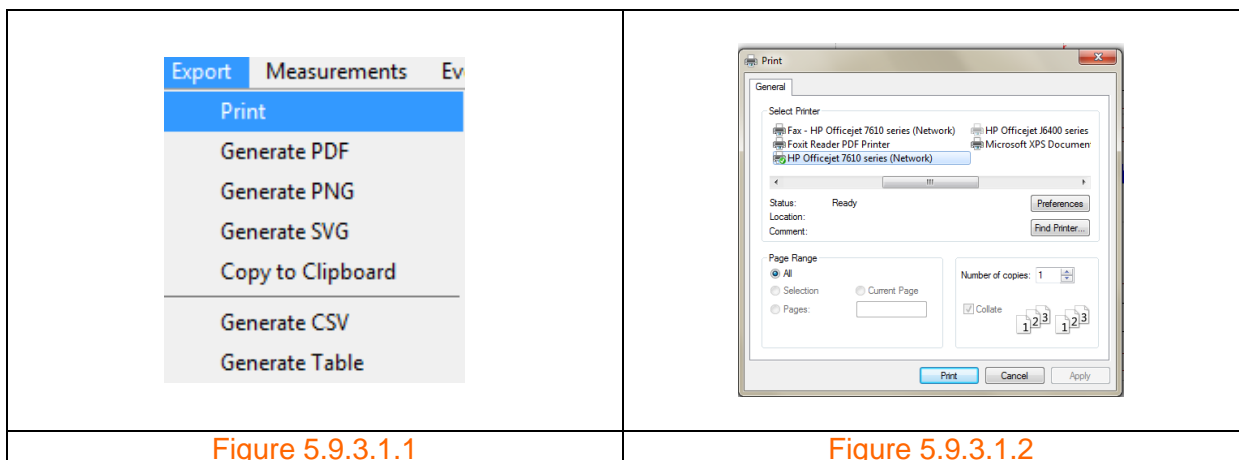

Step 2: Select the desired printer and preferences and then click on the 'Print' button.

5.9.3.2 Generate PDF

The user is able to convert the graph in to a PDF.

Step 1: Click the 'Export' menu shown in figure 5.9.3.2.1. A drop down box appears as shown in figure 5.9.3.2.2.

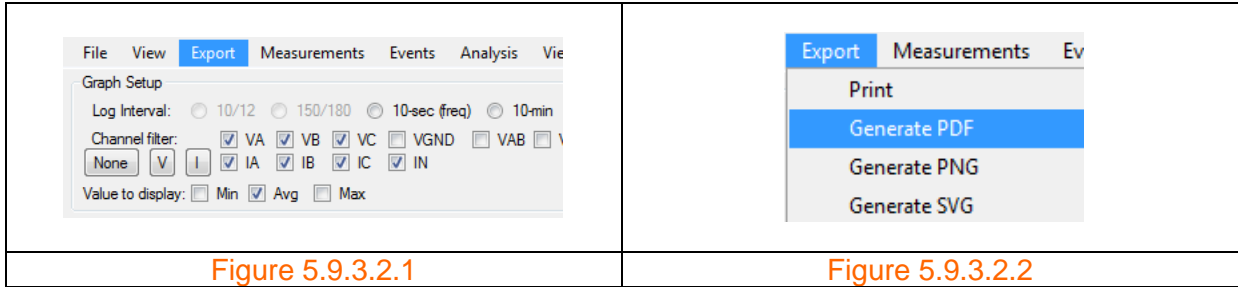

Step 2: Hover and click on 'Generate PDF'. A window opens as shown in figure 5.9.3.2.3 allowing the user to enter a file name and save to a particular folder. Click 'Save'.

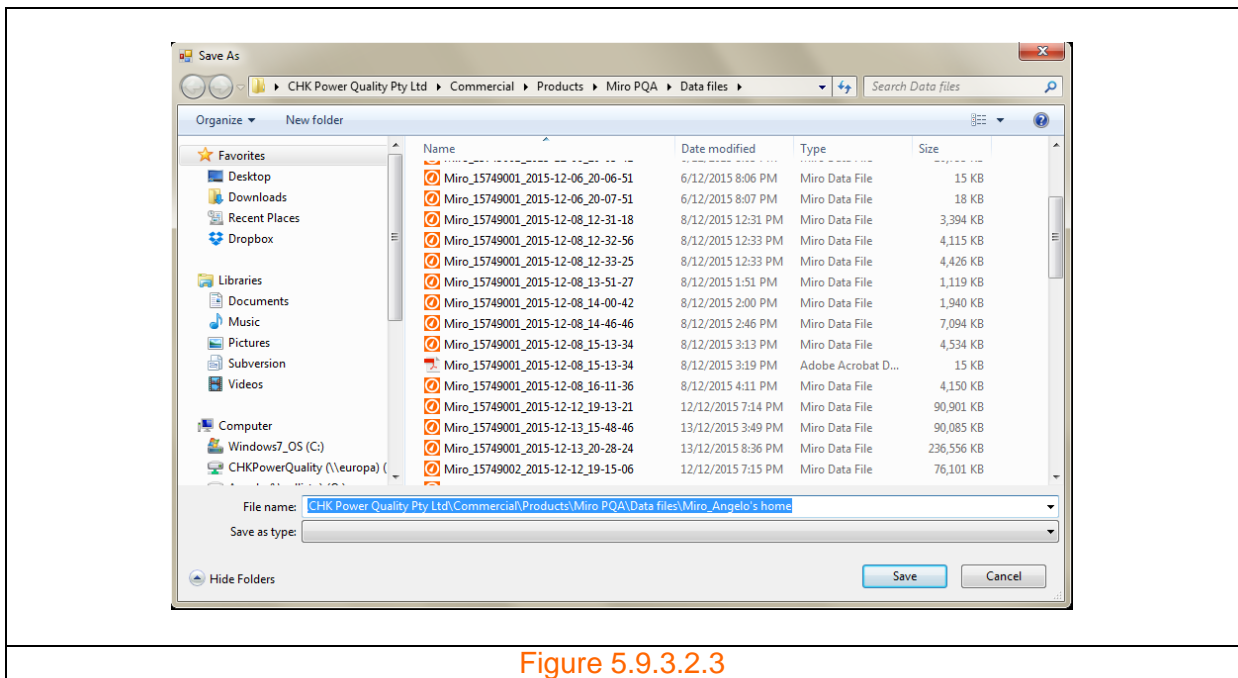

Step 3: Click on the saved .PDF. Example .PDF is shown in figure 5.9.3.2.4.

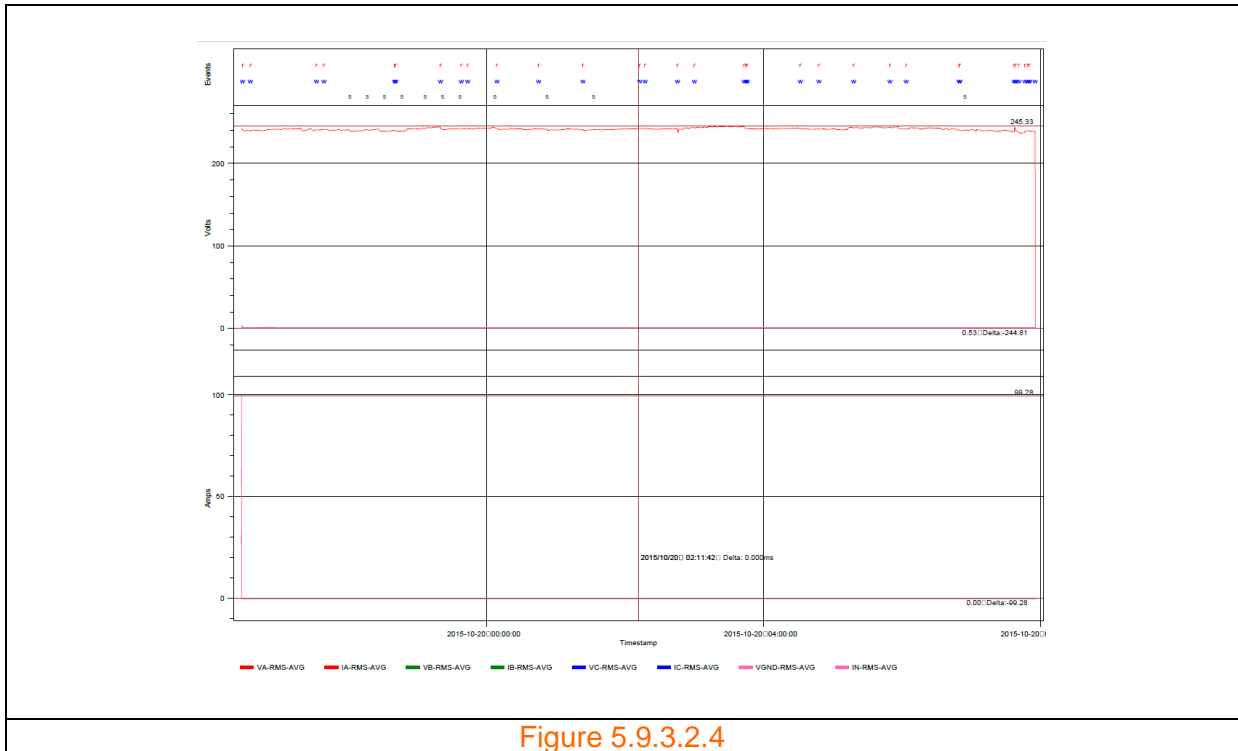

Figure 5.9.3.2.4

5.9.3.3 Generate PNG

The user is able to convert the graph in to a PNG. Follow the steps outlined in section 5.9.3.2, but select the 'Generate PNG' button rather than the 'Generate PDF' button.

5.9.3.4 Generate SVG

The user is able to convert the graph in to a SVG. Follow the steps outlined in section 5.9.3.2, but select the 'Generate SVG' button rather than the 'Generate PDF' button.

5.9.3.5 Copy to clipboard

The user is able to copy a graph to the Clipboard.

Step 1: Click the 'Export' menu shown in figure 5.9.3.5.1. A drop down box appears as shown in figure 5.9.3.5.2.

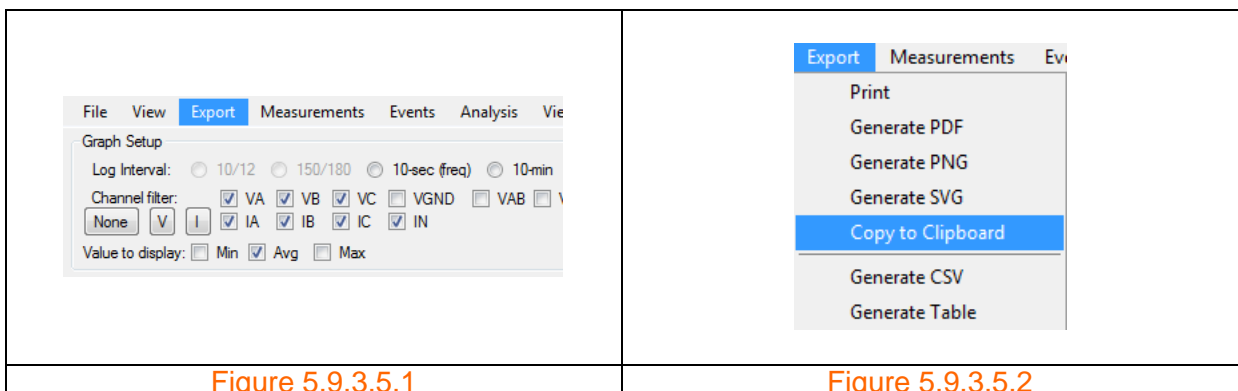

Figure 5.9.3.5.1

Figure 5.9.3.5.2

Step 2: Hover and click on 'Copy to Clipboard'.

5.9.3.6 Generate CSV

The user is able to save the viewed data to a .CSV file.

Step 1: Click the 'Export' menu shown in figure 5.9.3.6.1. A drop down box appears as shown in figure 5.9.3.6.2.

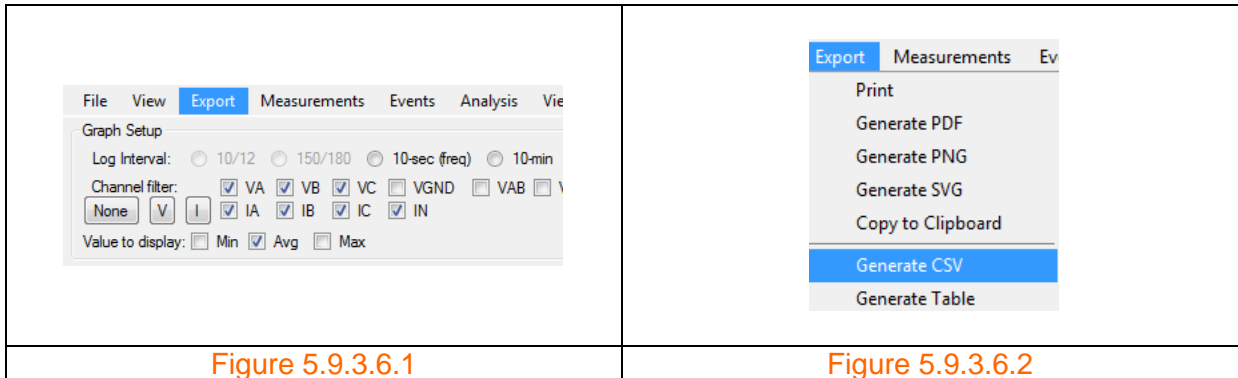

Step 2: Hover and click on 'Generate CSV'. A window opens as shown in figure 5.9.3.6.3 allowing the user to enter a file name and save to a particular folder. Click 'Save'.

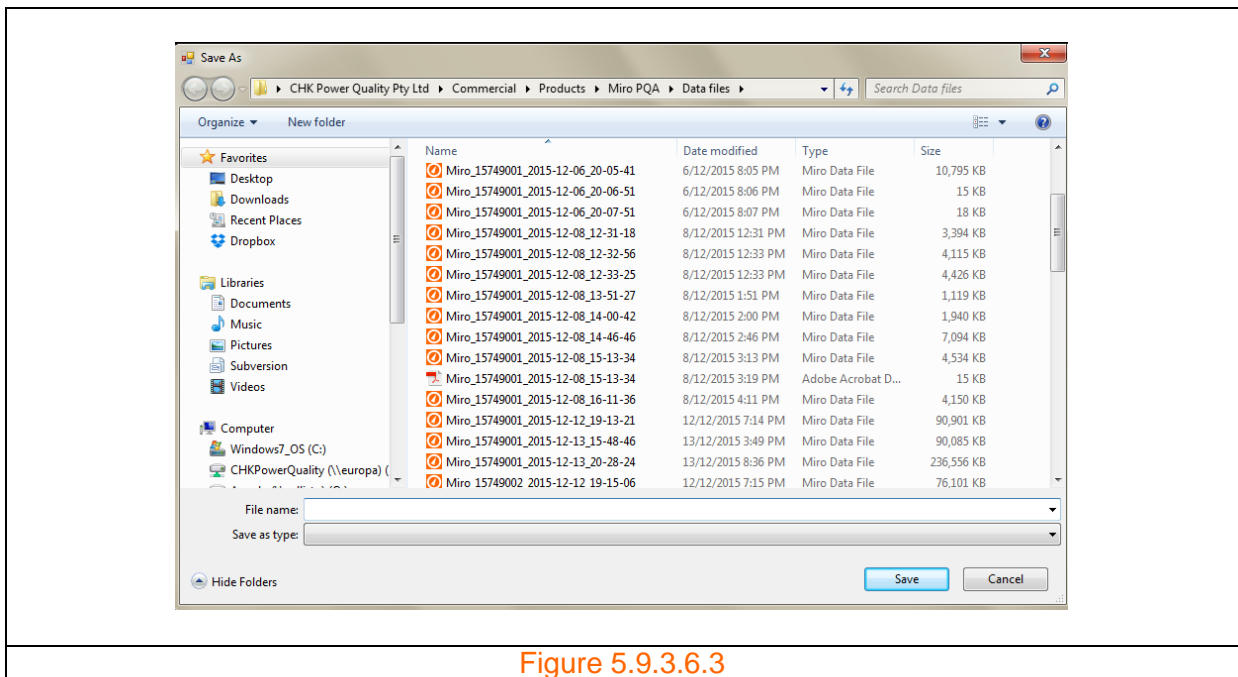

Step 3: Click on the saved .CSV file. Example .CSV file is shown in figure 5.9.3.6.4.

Timestamp	VA-RMS-AVG	IA-RMS-AVG	VB-RMS-AVG	IB-RMS-AVG	VC-RMS-AVG	IC-RMS-AVG	VGND-RMS-AVG	IN-RMS-AVG
27:35.0	241.97	30.58	3.16	31.44	3.63	63.83	2.86	99.28
27:40.1	242.12	0	1.32	0	1.9	0	1.42	0
27:45.2	241.88	0	0.98	0	1.56	0	1.22	0
27:50.0	241.67	0	0.88	0	1.42	0	1.18	0
27:55.2	241.54	0	0.84	0	1.37	0	1.16	0
28:00.1	241.7	0	0.81	0	1.35	0	1.15	0
28:05.0	241.86	0	0.78	0	1.35	0	1.11	0
28:10.2	241.86	0	0.71	0	1.4	0	1.09	0
28:15.1	241.93	0	0.69	0	1.47	0	1.11	0
28:20.0	241.93	0	0.67	0	1.49	0	1.11	0
28:25.2	242.22	0	0.65	0	1.56	0	1.11	0
28:30.2	242.06	0	0.65	0	1.58	0	1.11	0
28:35.1	240.93	0	0.63	0	1.55	0	1.11	0
28:40.1	240.71	0	0.62	0	1.54	0	1.1	0
28:45.0	240.68	0	0.63	0	1.52	0	1.11	0
28:50.0	240.63	0	0.65	0	1.47	0	1.13	0
28:55.2	240.18	0	0.64	0	1.45	0	1.13	0
29:00.2	239.7	0	0.65	0	1.46	0	1.13	0
29:05.1	239.83	0	0.64	0	1.44	0	1.13	0
29:10.1	240.3	0	0.64	0	1.36	0	1.12	0
29:15.1	240.67	0	0.63	0	1.3	0	1.13	0
29:20.0	240.54	0	0.62	0	1.28	0	1.13	0
29:25.0	240.6	0	0.63	0	1.26	0	1.13	0
29:30.2	240.28	0	0.62	0	1.24	0	1.13	0
29:35.2	240.1	0	0.63	0	1.25	0	1.12	0
29:40.2	239.93	0	0.65	0	1.25	0	1.12	0
29:45.1	239.52	0	0.64	0	1.25	0	1.13	0
29:50.1	239.45	0	0.64	0	1.26	0	1.13	0
29:55.1	239.44	0	0.64	0	1.25	0	1.13	0
30:00.1	239.68	0	0.64	0	1.22	0	1.13	0
30:05.2	239.54	0	0.64	0	1.21	0	1.13	0
30:10.2	239.05	0	0.65	0	1.25	0	1.13	0
30:15.1	239.26	0	0.67	0	1.28	0	1.13	0
30:20.1	240.2	0	0.68	0	1.24	0	1.14	0
30:25.1	240.48	0	0.65	0	1.18	0	1.14	0
30:30.1	240.68	0	0.62	0	1.15	0	1.14	0
30:35.1	240.71	0	0.62	0	1.14	0	1.13	0
30:40.0	240.58	0	0.63	0	1.15	0	1.13	0

Figure 5.8.3.6.4

5.9.3.7 Generate table

The user is able to generate a table of the viewed data.

Step 1: Click the 'Export' menu shown in figure 5.9.3.7.1. A drop down box appears as shown in figure 5.9.3.7.2.

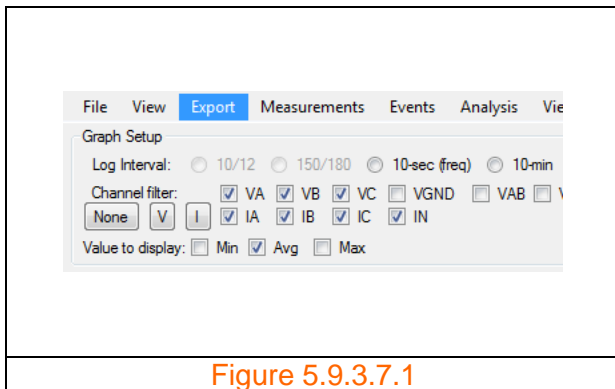

Figure 5.9.3.7.1

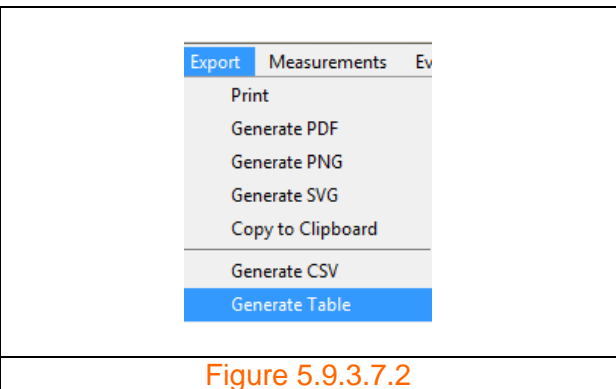
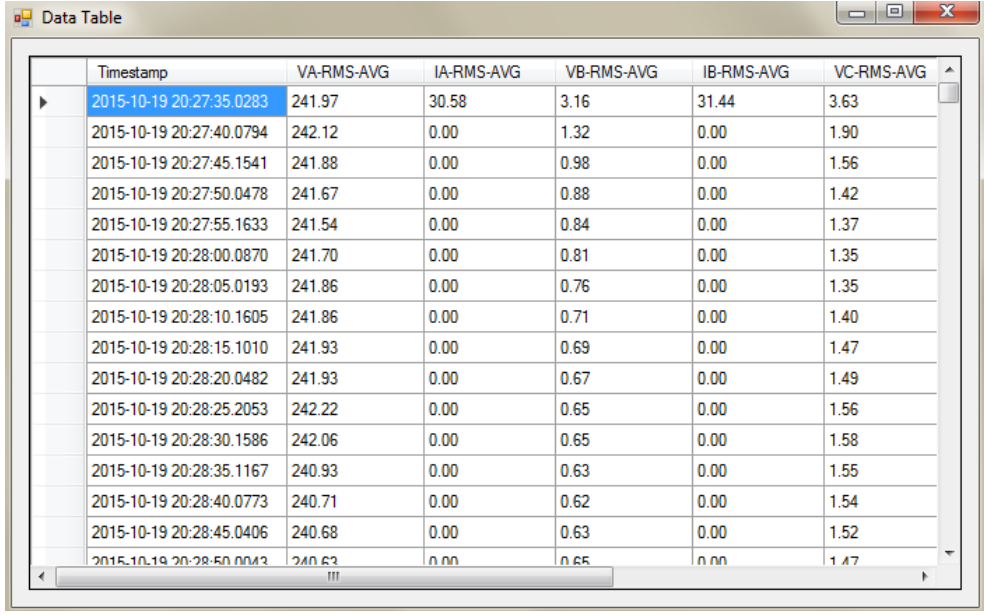

Figure 5.9.3.7.2

Step 2: Hover and click on 'Generate Table'. A 'Data Table' form appears as shown in figure 5.9.3.7.3.



Timestamp	VA-RMS-AVG	IA-RMS-AVG	VB-RMS-AVG	IB-RMS-AVG	VC-RMS-AVG
2015-10-19 20:27:35.0283	241.97	30.58	3.16	31.44	3.63
2015-10-19 20:27:40.0794	242.12	0.00	1.32	0.00	1.90
2015-10-19 20:27:45.1541	241.88	0.00	0.98	0.00	1.56
2015-10-19 20:27:50.0478	241.67	0.00	0.88	0.00	1.42
2015-10-19 20:27:55.1633	241.54	0.00	0.84	0.00	1.37
2015-10-19 20:28:00.0870	241.70	0.00	0.81	0.00	1.35
2015-10-19 20:28:05.0193	241.86	0.00	0.76	0.00	1.35
2015-10-19 20:28:10.1605	241.86	0.00	0.71	0.00	1.40
2015-10-19 20:28:15.1010	241.93	0.00	0.69	0.00	1.47
2015-10-19 20:28:20.0482	241.93	0.00	0.67	0.00	1.49
2015-10-19 20:28:25.2053	242.22	0.00	0.65	0.00	1.56
2015-10-19 20:28:30.1586	242.06	0.00	0.65	0.00	1.58
2015-10-19 20:28:35.1167	240.93	0.00	0.63	0.00	1.55
2015-10-19 20:28:40.0773	240.71	0.00	0.62	0.00	1.54
2015-10-19 20:28:45.0406	240.68	0.00	0.63	0.00	1.52
2015-10-19 20:28:50.0043	240.63	0.00	0.65	0.00	1.47

Figure 5.9.3.7.3

5.9.4 Measurements

There are five measurement groups as shown in figure 5.9.4.1 and include RMS and Frequency, Power and Unbalance, Harmonics, Flicker and Temperature.

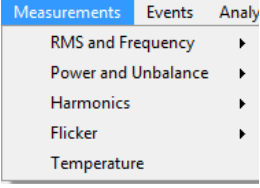

Measurements	Events	Analy
RMS and Frequency		▶
Power and Unbalance		▶
Harmonics		▶
Flicker		▶
Temperature		

Figure 5.9.4.1

5.9.4.1 RMS and frequency

Clicking on 'RMS and Frequency' in the 'Measurements' menu generates a sub menu listing 'TRMS', 'DC', 'AC', 'Crest Factor', 'Fundamental Magnitude', 'Fundamental Phase', 'Frequency', 'Underdeviation' and 'Overdevaition' measures as shown in figure 5.9.4.1.1.

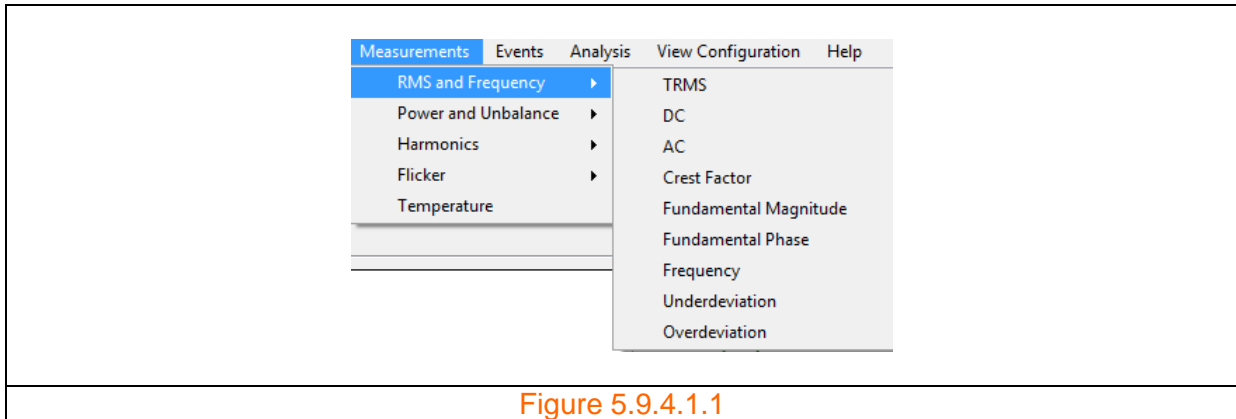

Figure 5.9.4.1.1

Clicking on 'TRMS' generates graphs displaying voltage and current for selected channels as shown in figure 5.9.4.1.2.

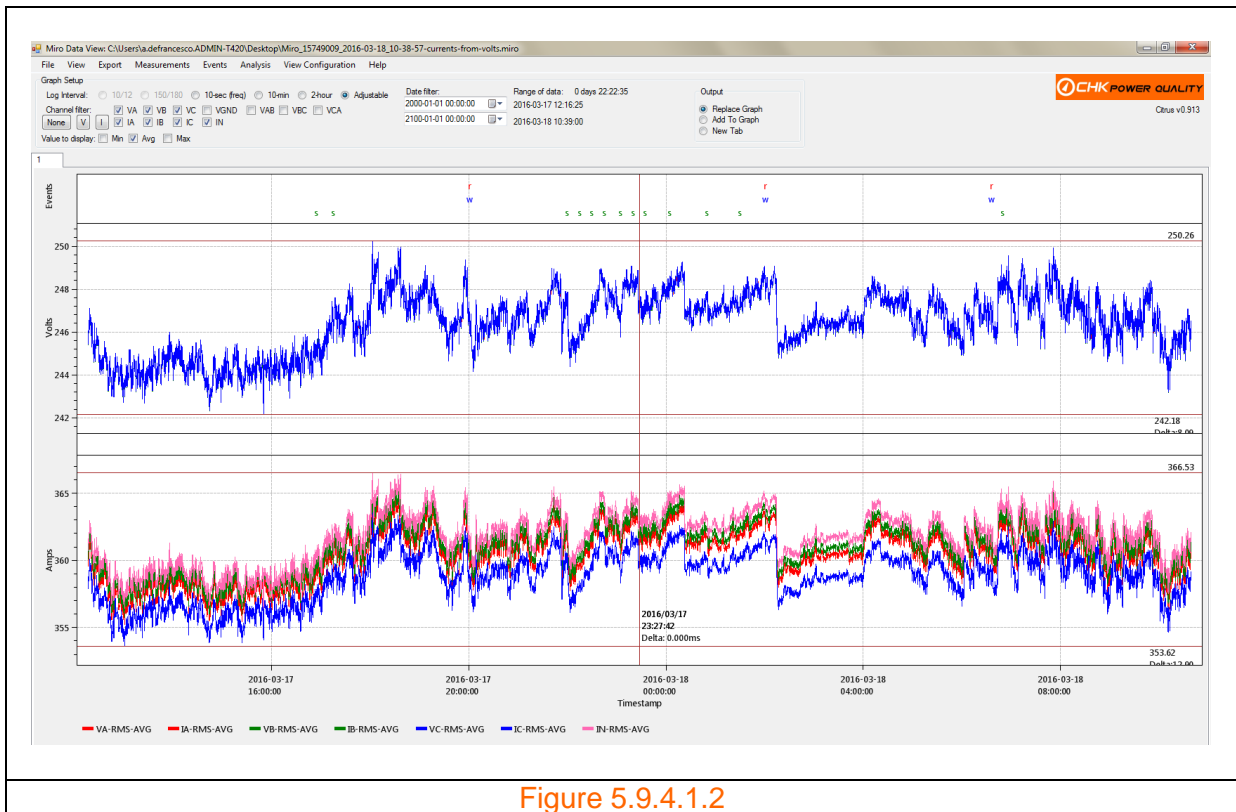
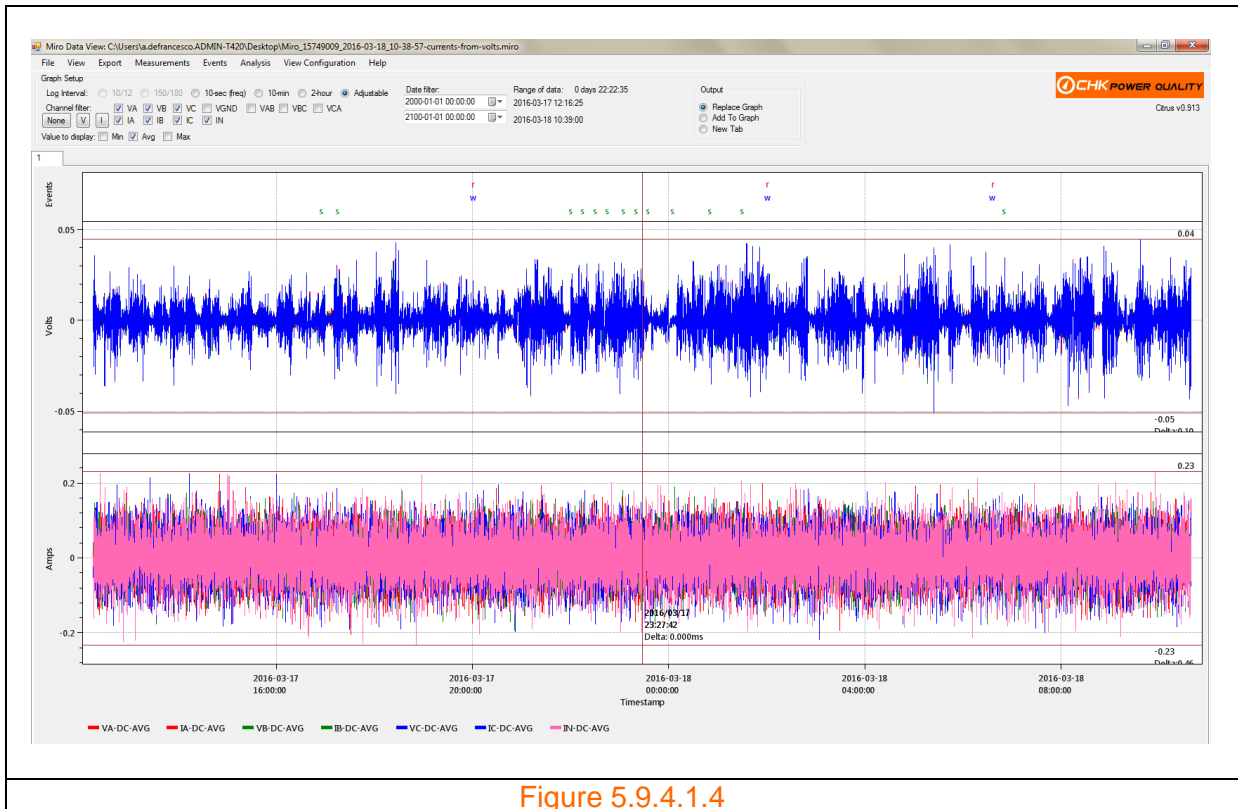
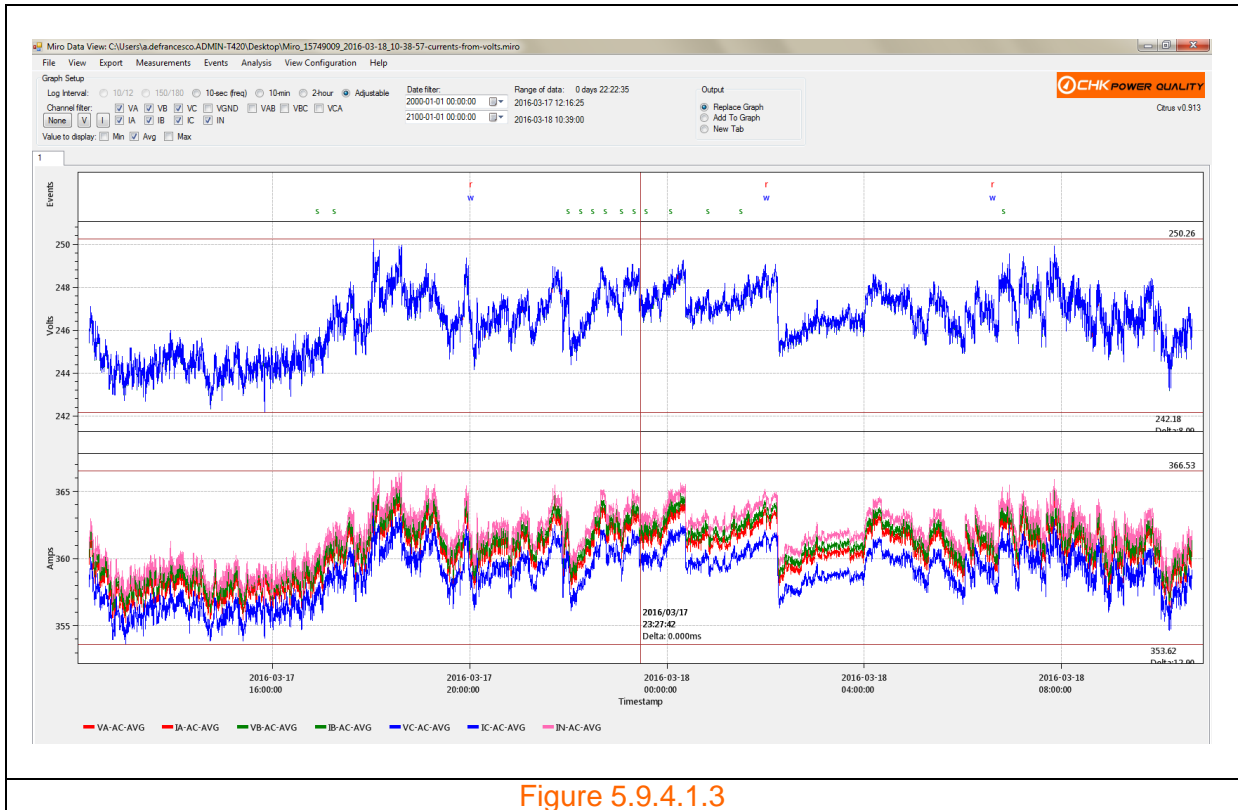

Figure 5.9.4.1.2

Clicking on 'AC' or 'DC' generates graphs displaying only AC or DC components of the voltage and current for selected channels as shown in figures 5.9.4.1.3 and 5.9.4.1.4 respectively.



Clicking on 'Crest Factor' generates a graph displaying the crest factor for selected channels as shown in figure 5.9.4.1.5.

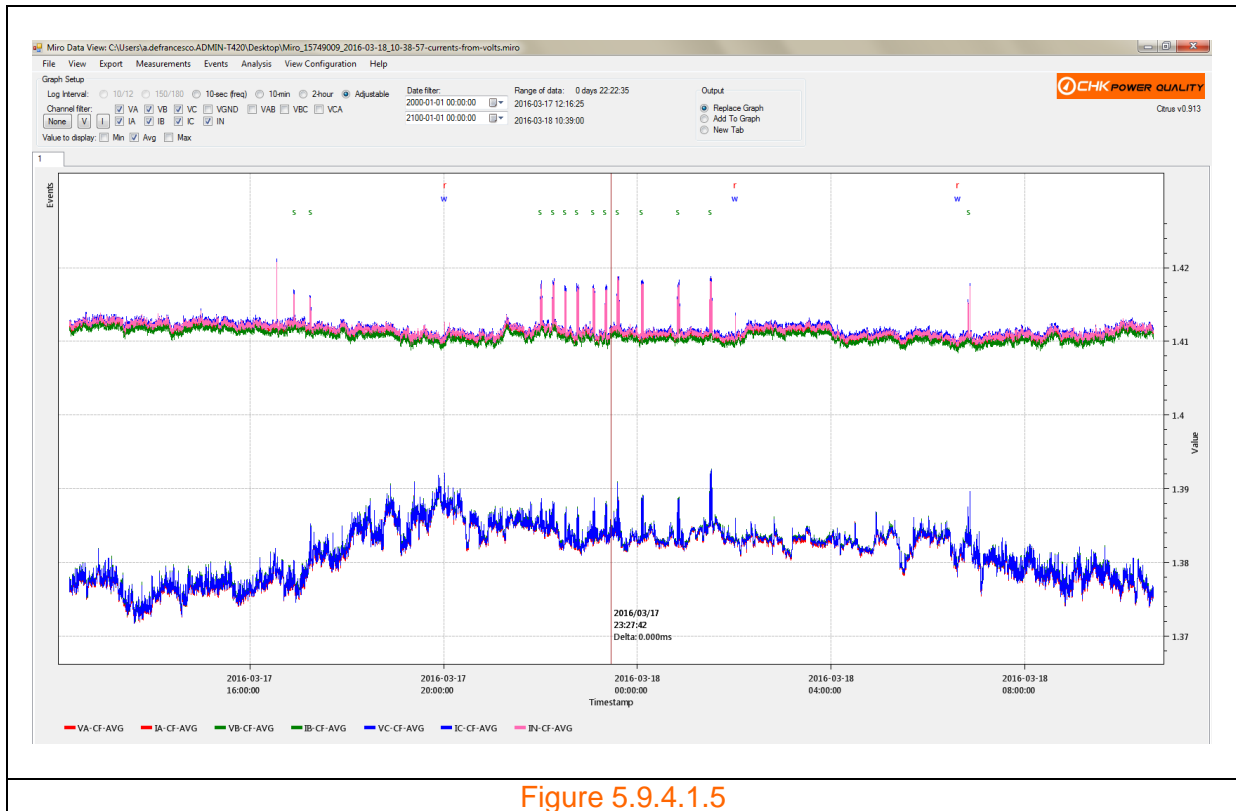
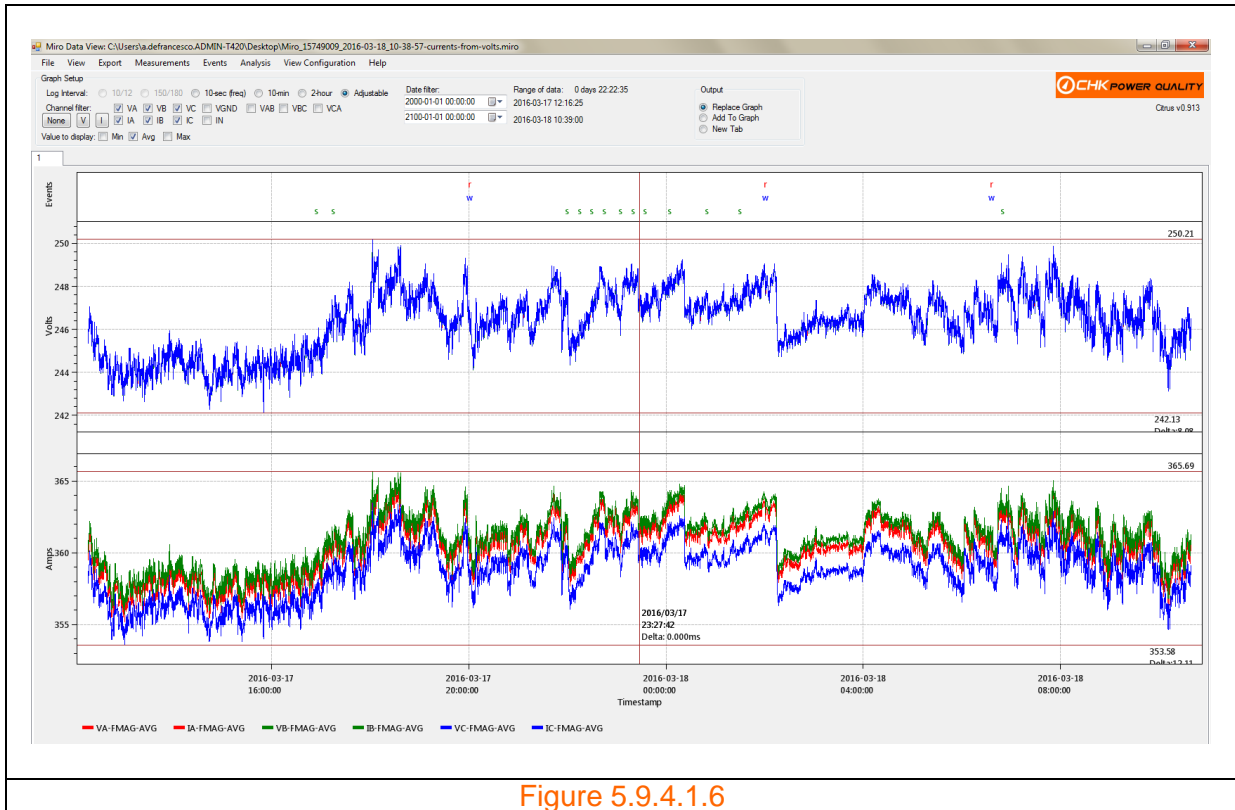

Figure 5.9.4.1.5

Clicking on 'Fundamental Magnitude' generates graphs displaying the fundamental magnitude for selected channels as shown in figure 5.9.4.1.6.



Clicking on 'Fundamental Phase' generates a graph displaying the fundamental phase for selected channels as shown in figure 5.9.4.1.7.



Clicking on 'Frequency' generates a graph displaying the frequency for only VA as shown in figure 5.9.4.1.8.

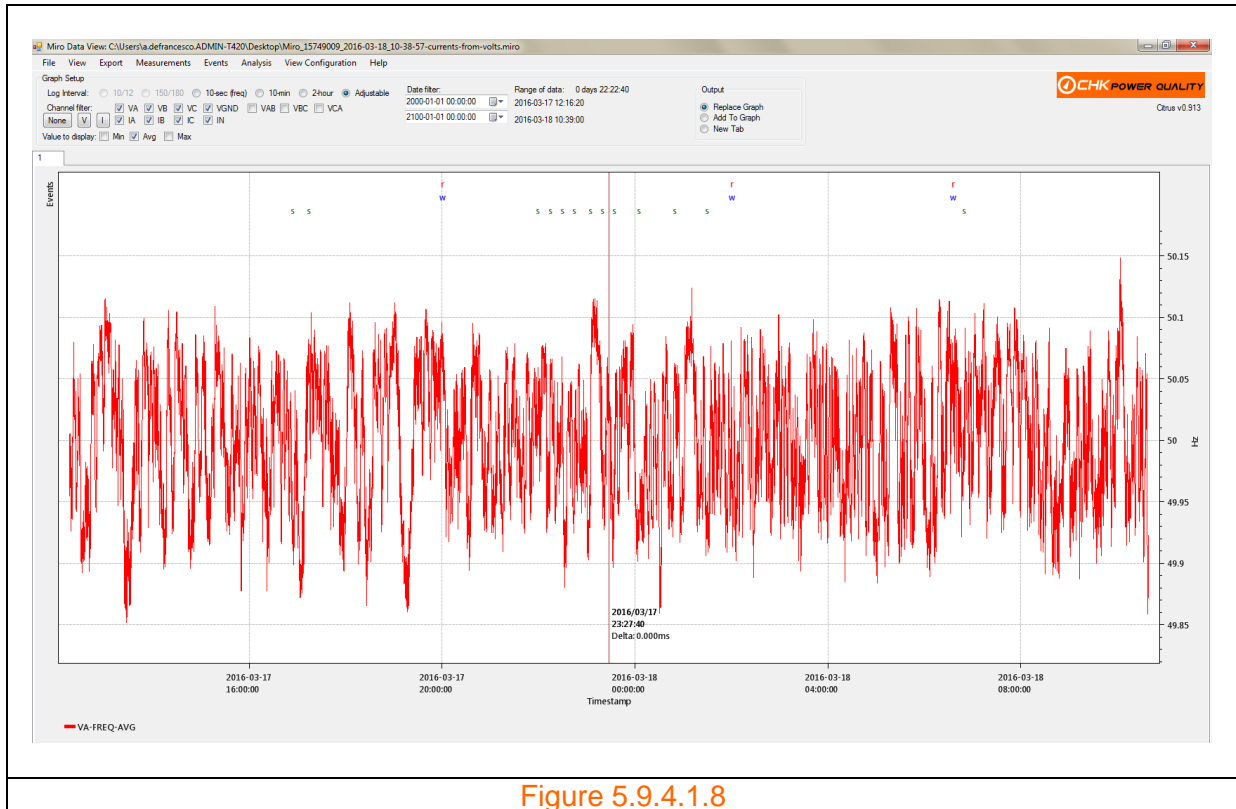

Figure 5.9.4.1.8

Clicking on 'Underdeviation' or 'Overdeviation' generates graphs displaying the under deviation and over deviation measures for selected voltage channels, and shown in figures 5.9.4.1.9 and 5.9.4.1.10 respectively.

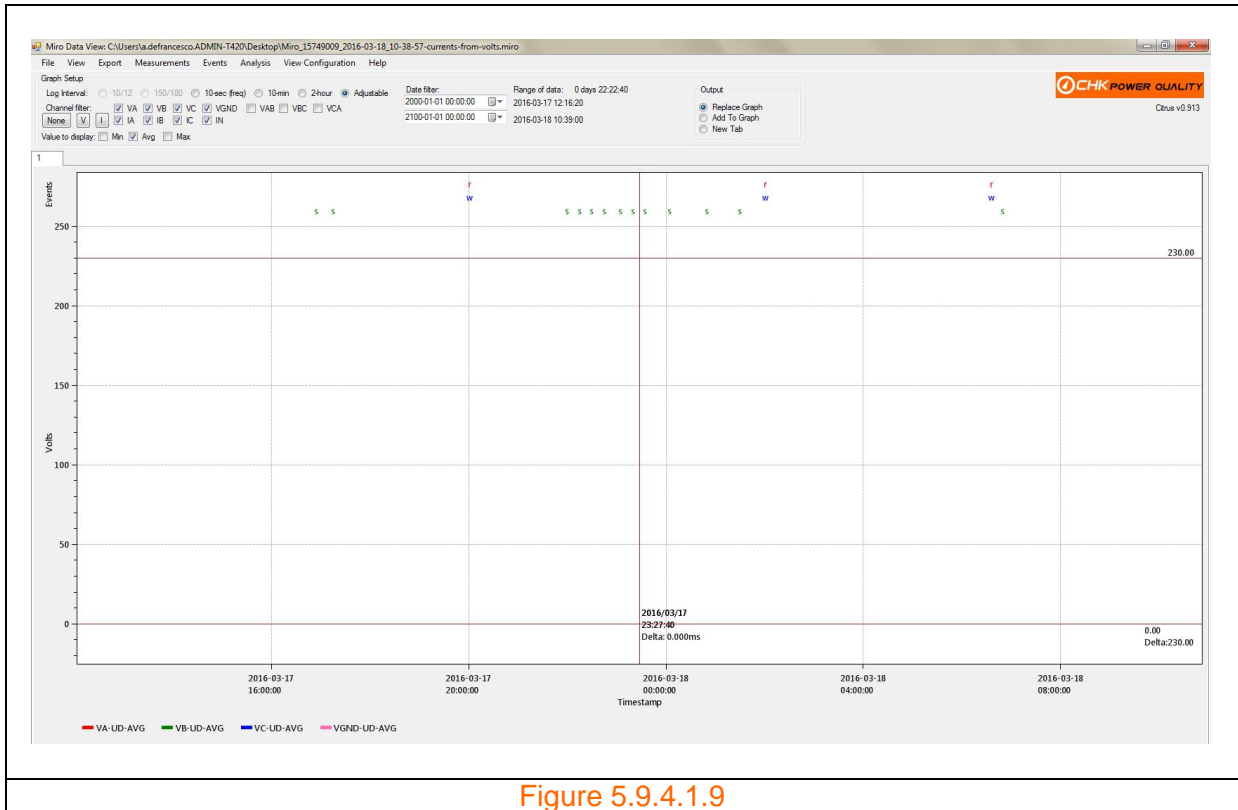

Figure 5.9.4.1.9

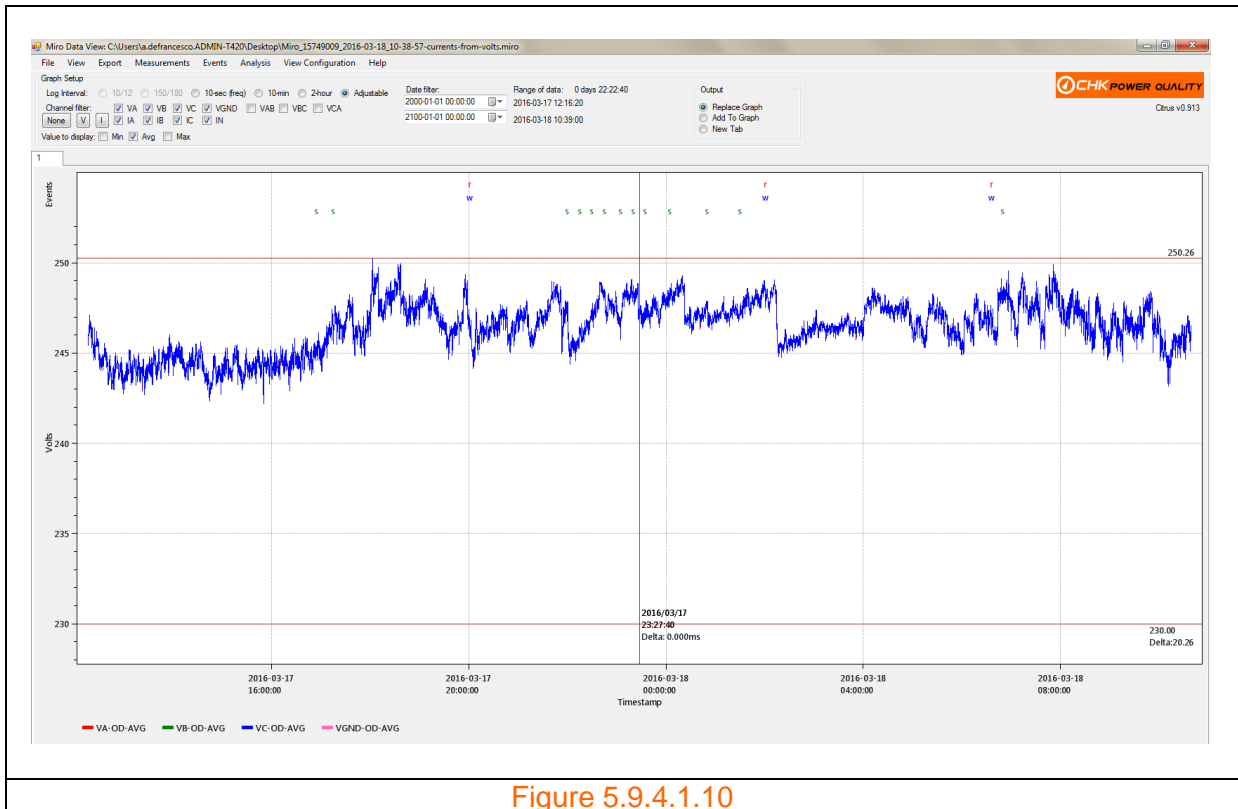

Figure 5.9.4.1.10

5.9.4.2 Power and unbalance

Clicking on 'Power and Unbalance' in the 'Measurements' menu generates a sub menu listing 'Real Power', 'Reactive Power', 'Apparent Power', 'True Power Factor', 'Displacement Power Factor', 'Real Power Total', 'Reactive Power Total', 'Apparent Power Total', 'Unbalance (Negative Sequence)' and 'Unbalance (Zero Sequence)' measures as shown in figure 5.9.4.2.1.

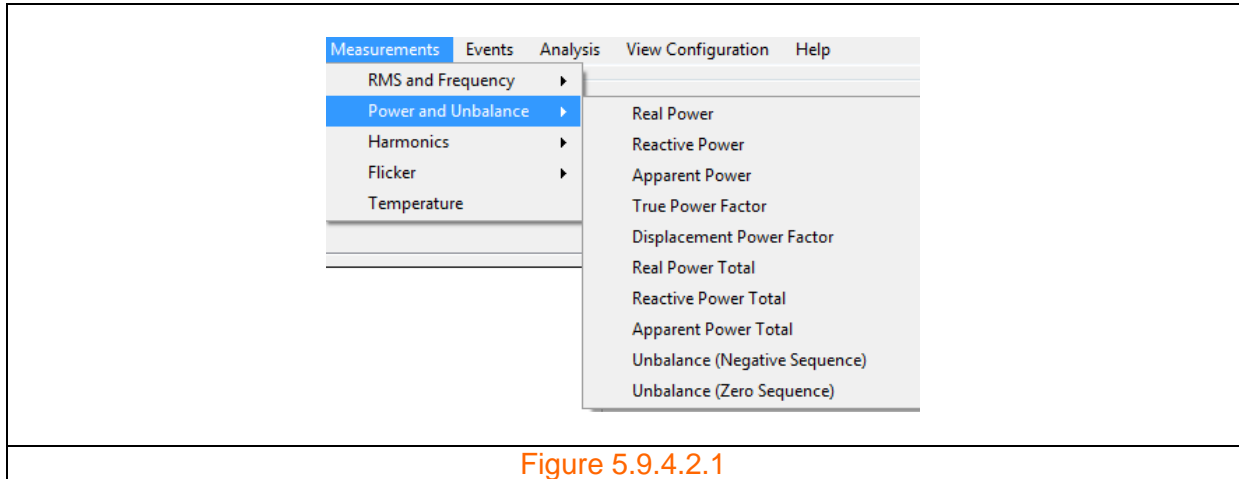

Figure 5.9.4.2.1

Clicking on 'Real Power' generates a graph displaying the real power for each phase as shown in figure 5.9.4.2.2.

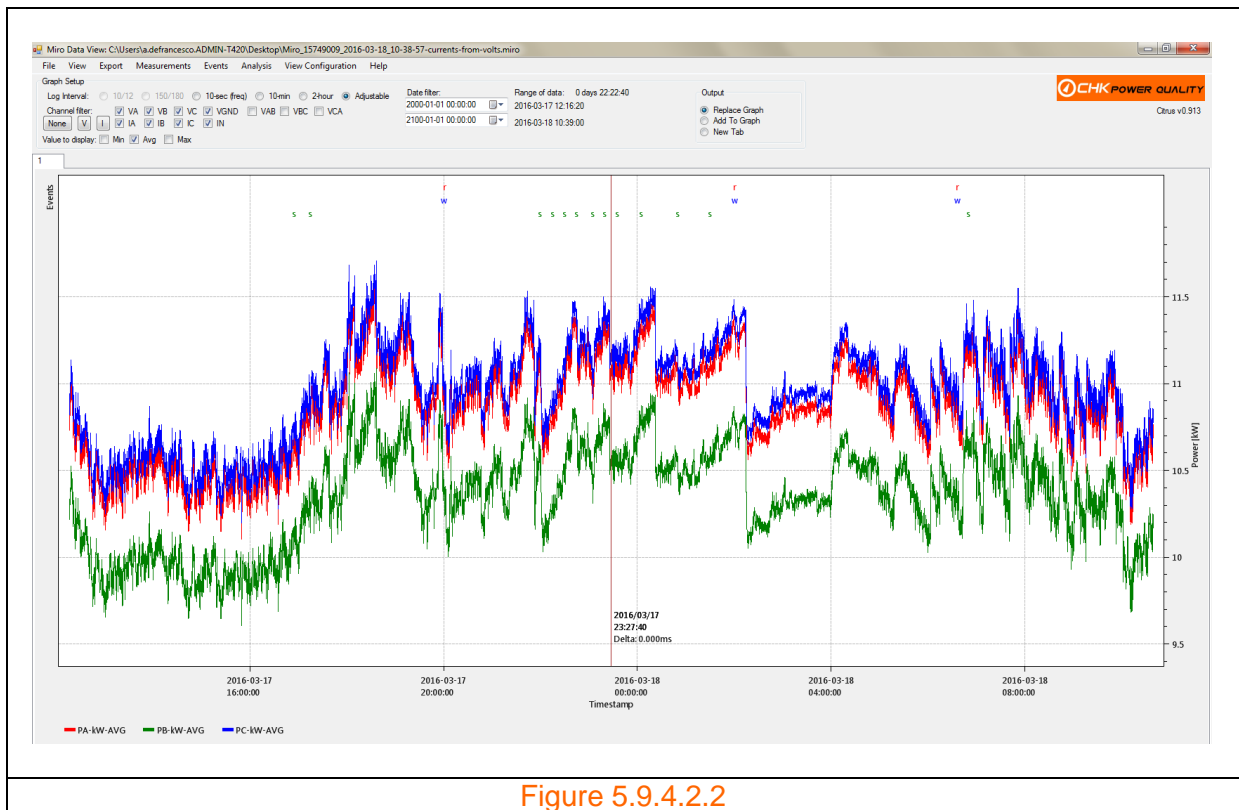

Figure 5.9.4.2.2

Clicking on 'Reactive Power' generates a graph displaying the reactive power for each phase as shown in figure 5.9.4.2.3.

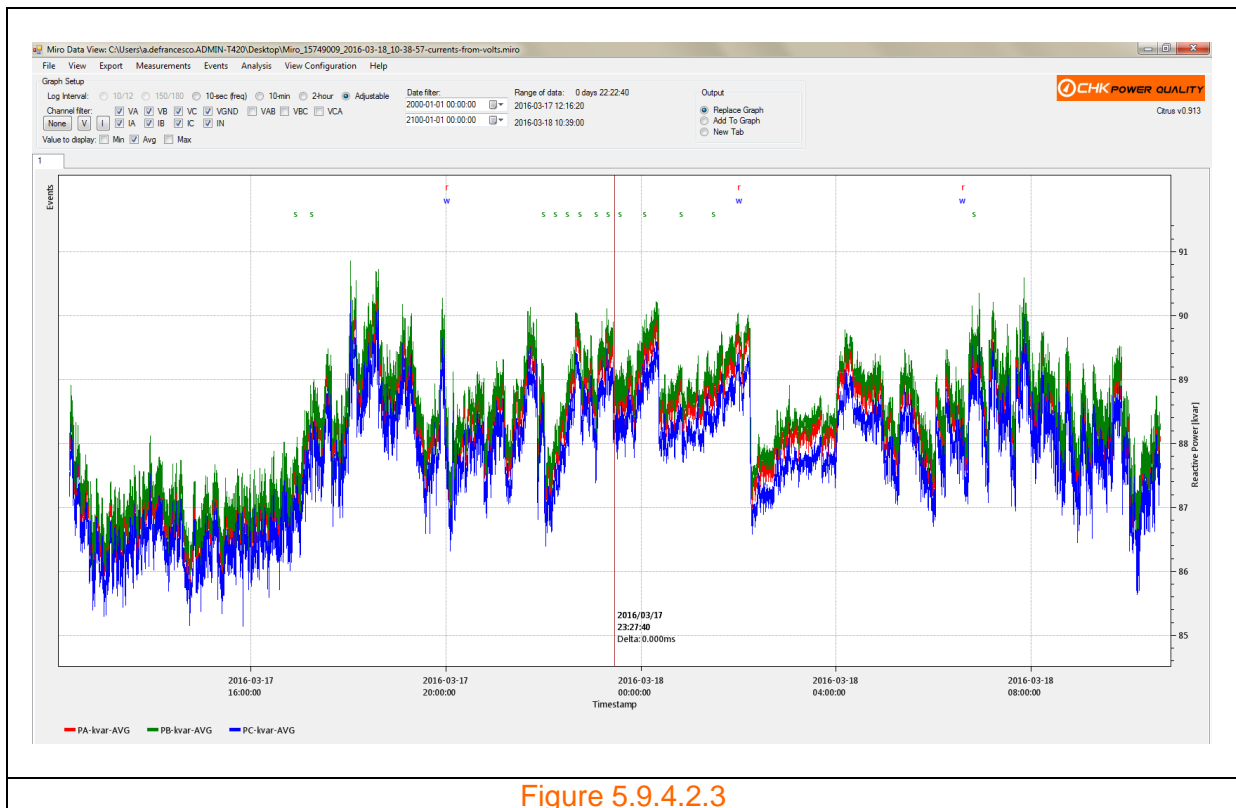
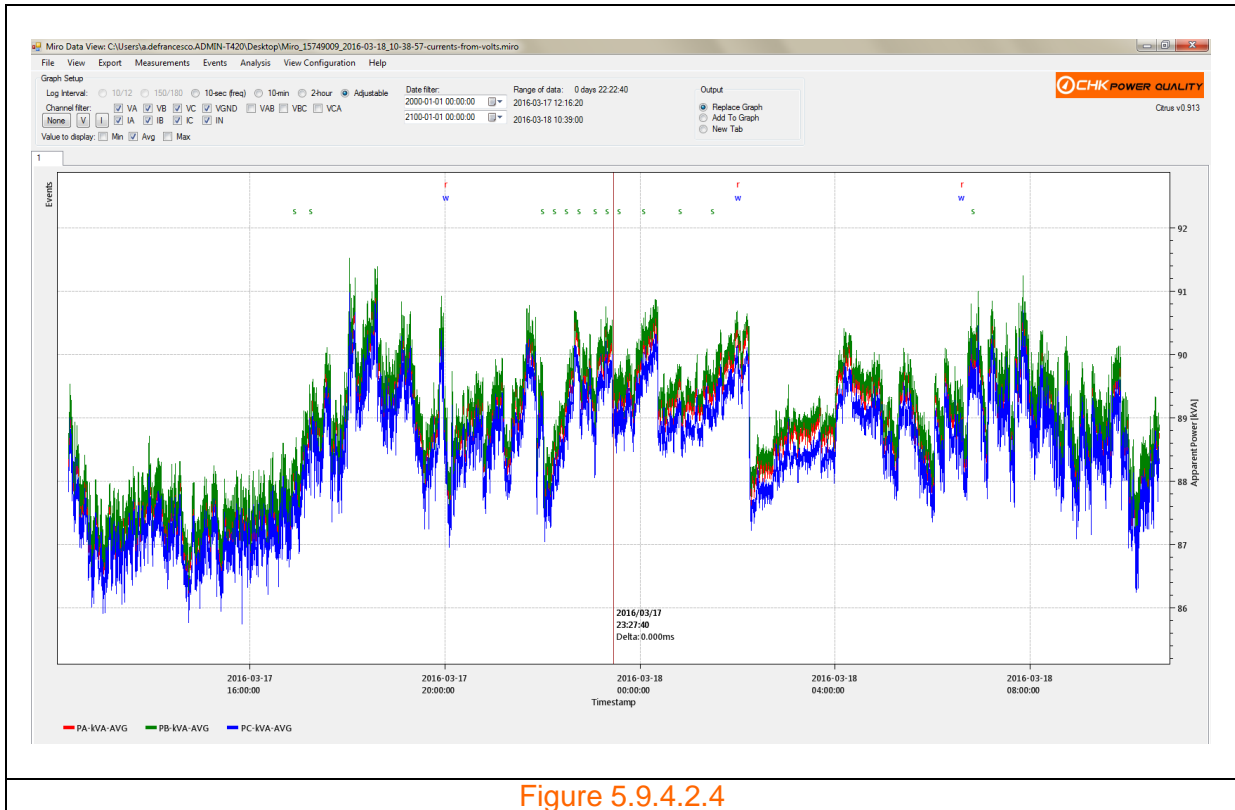
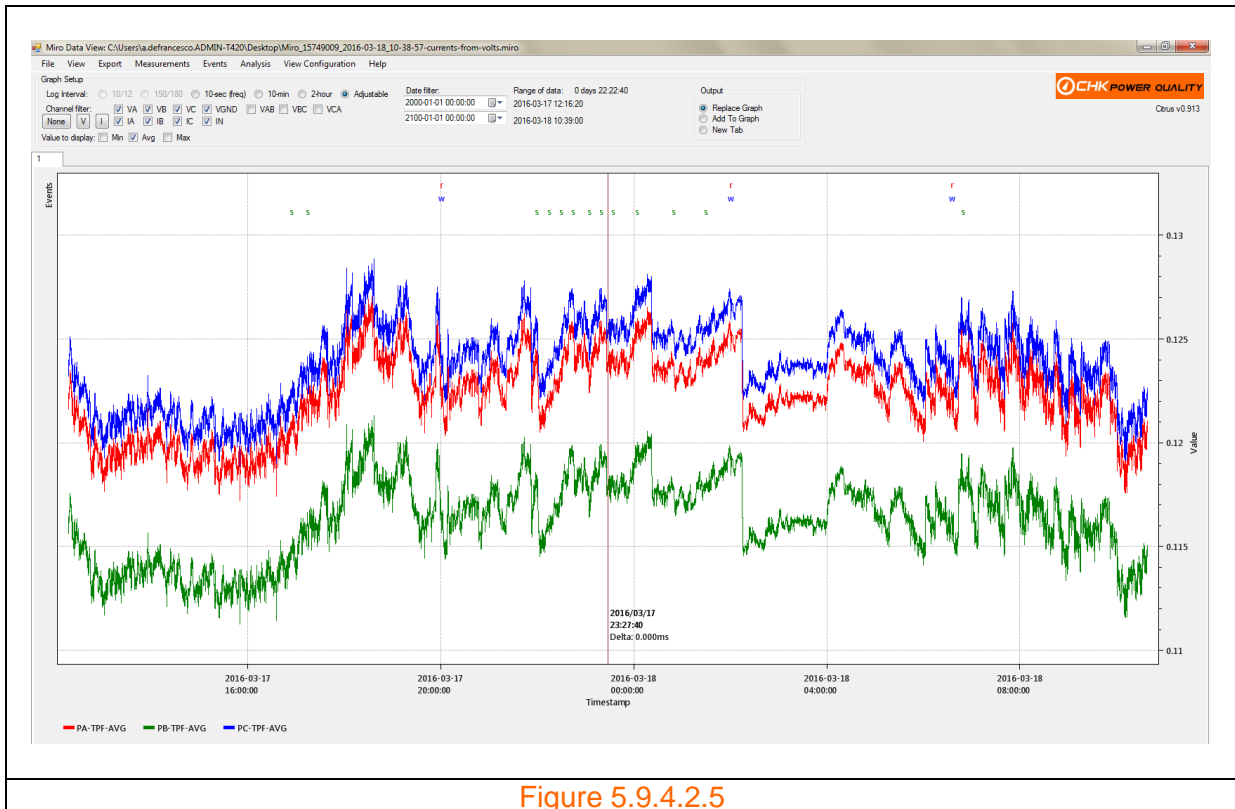

Figure 5.9.4.2.3

Clicking on 'Apparent Power' generates a graph displaying the apparent power for each phase as shown in figure 5.9.4.2.4.



Clicking on 'True Power Factor' generates a graph displaying the true power factor for each phase as shown in figure 5.9.4.2.5.



Clicking on 'Displacement Power Factor' generates a graph displaying the displacement power factor for each phase as shown in figure 5.9.4.2.6.

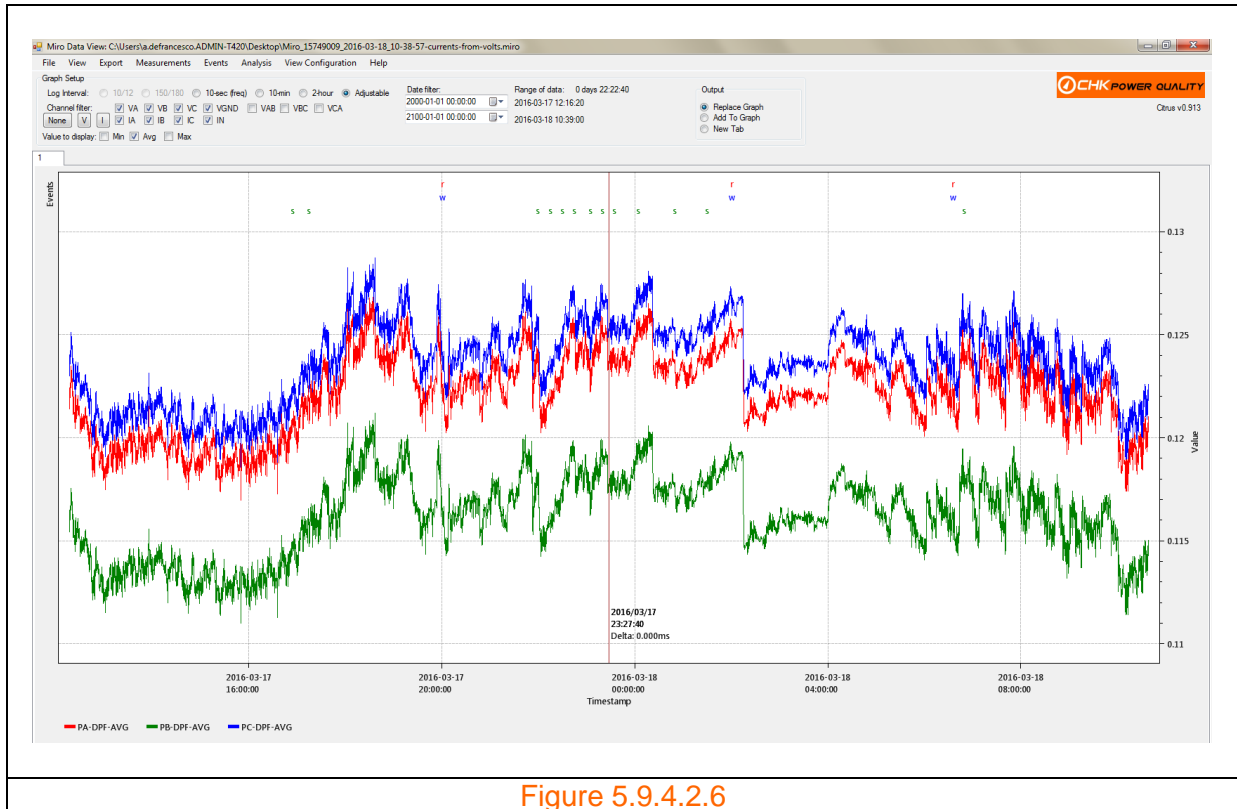

Figure 5.9.4.2.6

Clicking on 'Real Power Total' generates a graph displaying the total real power as shown in figure 5.9.4.2.7.

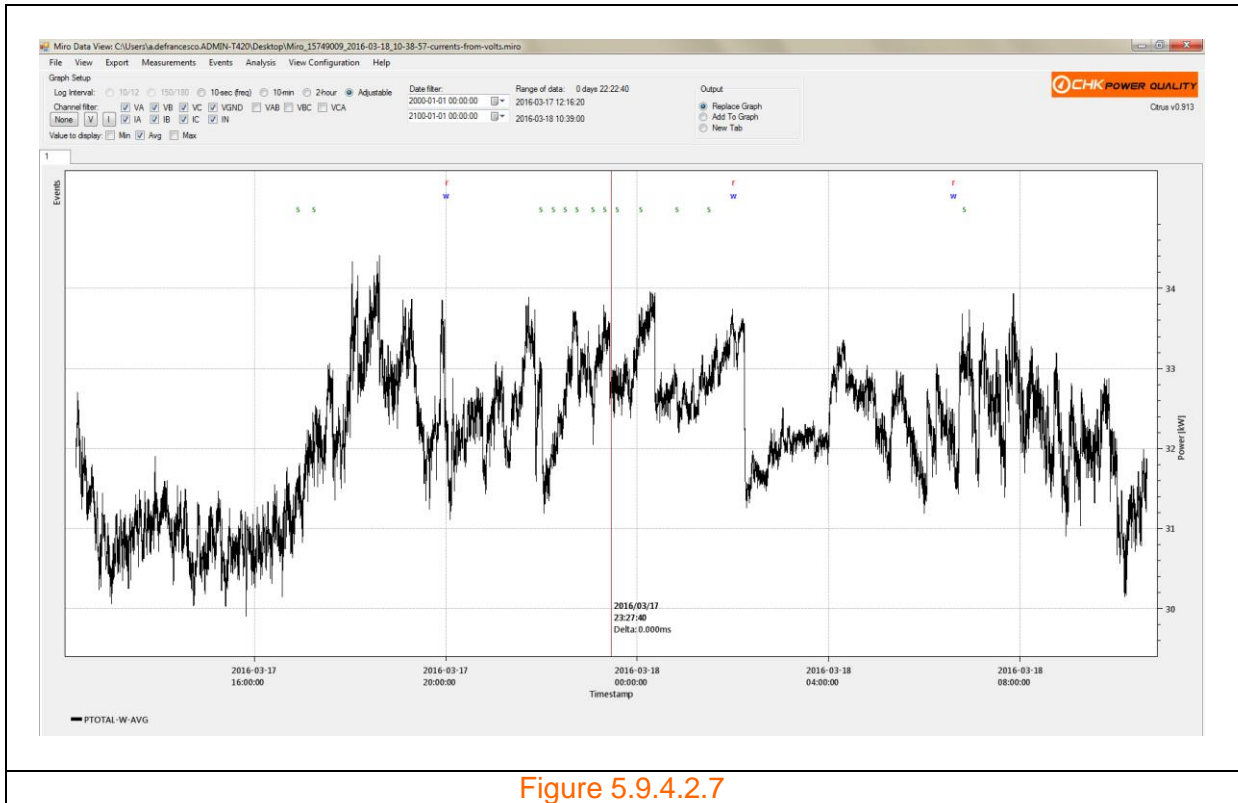

Figure 5.9.4.2.7

Clicking on 'Reactive Power Total' generates a graph displaying the total reactive power as shown in figure 5.9.4.2.8.

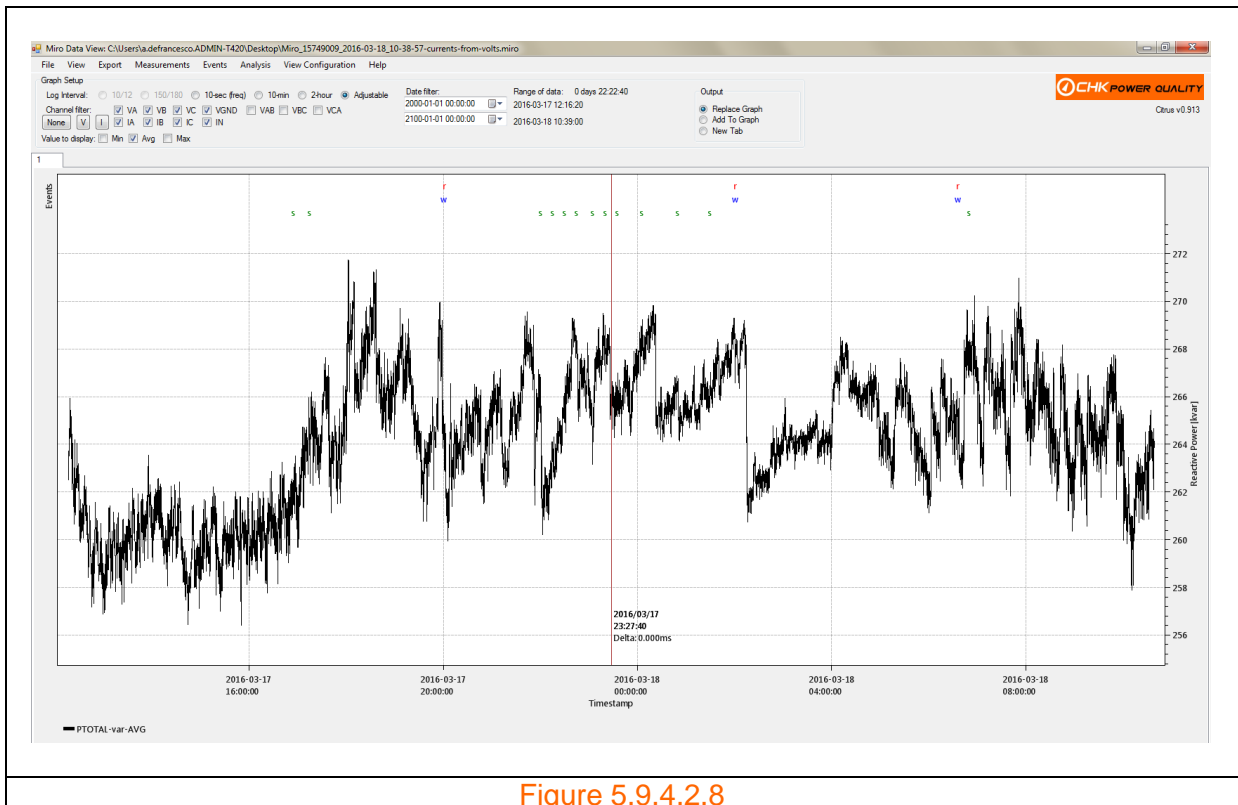

Figure 5.9.4.2.8

Clicking on 'Apparent Power Total' generates a graph displaying the total apparent power as shown in figure 5.9.4.2.9.

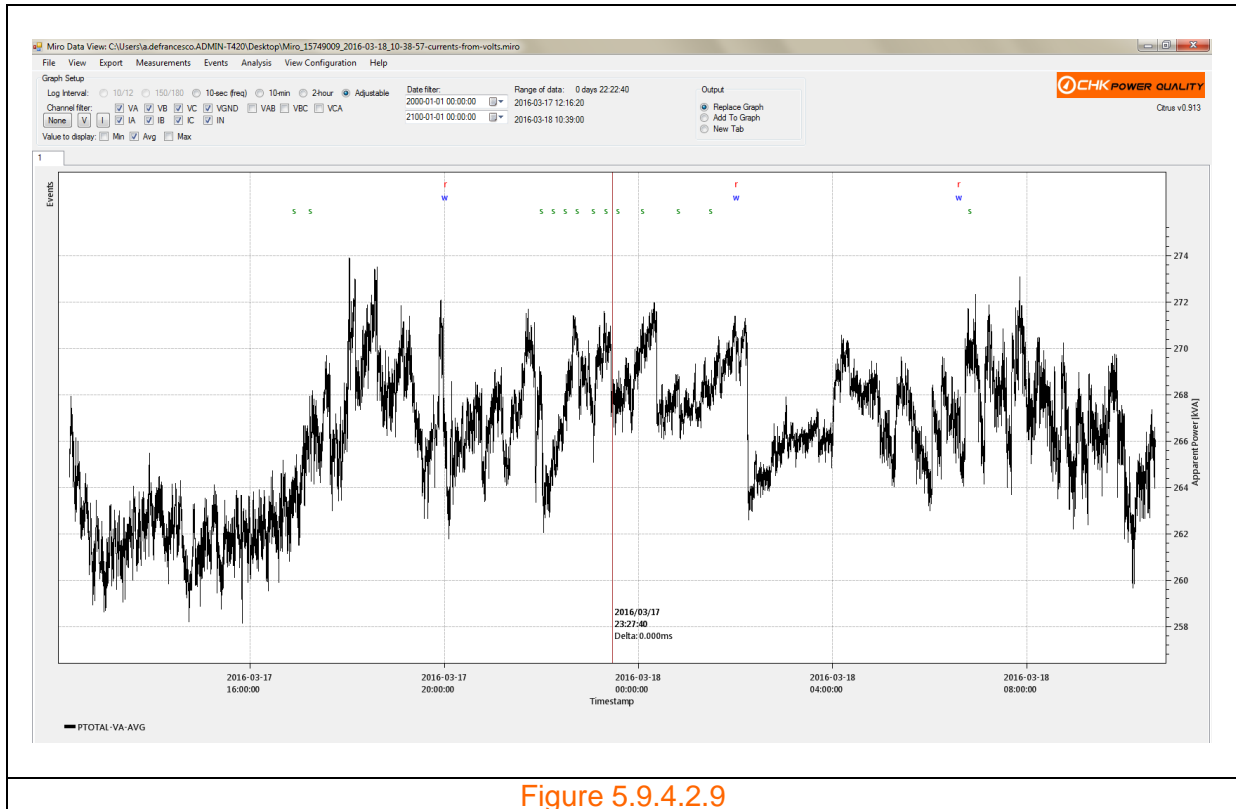
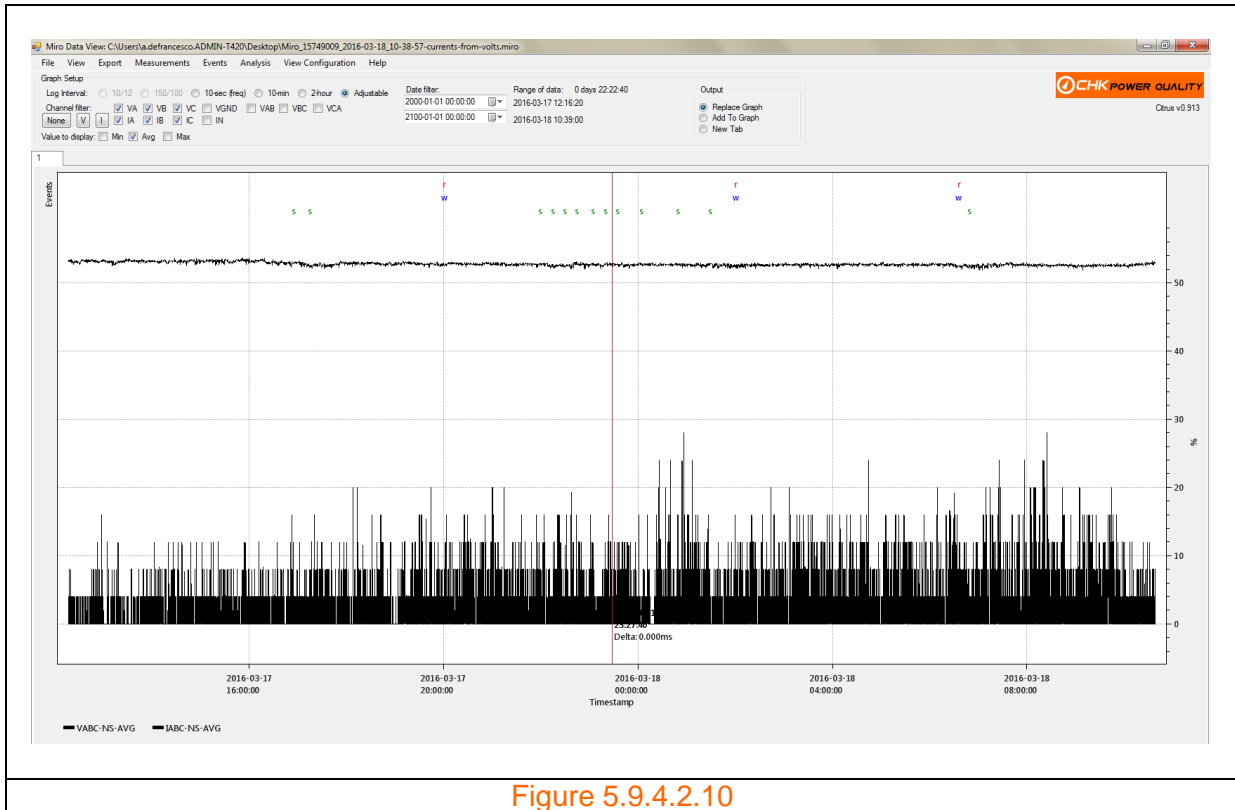
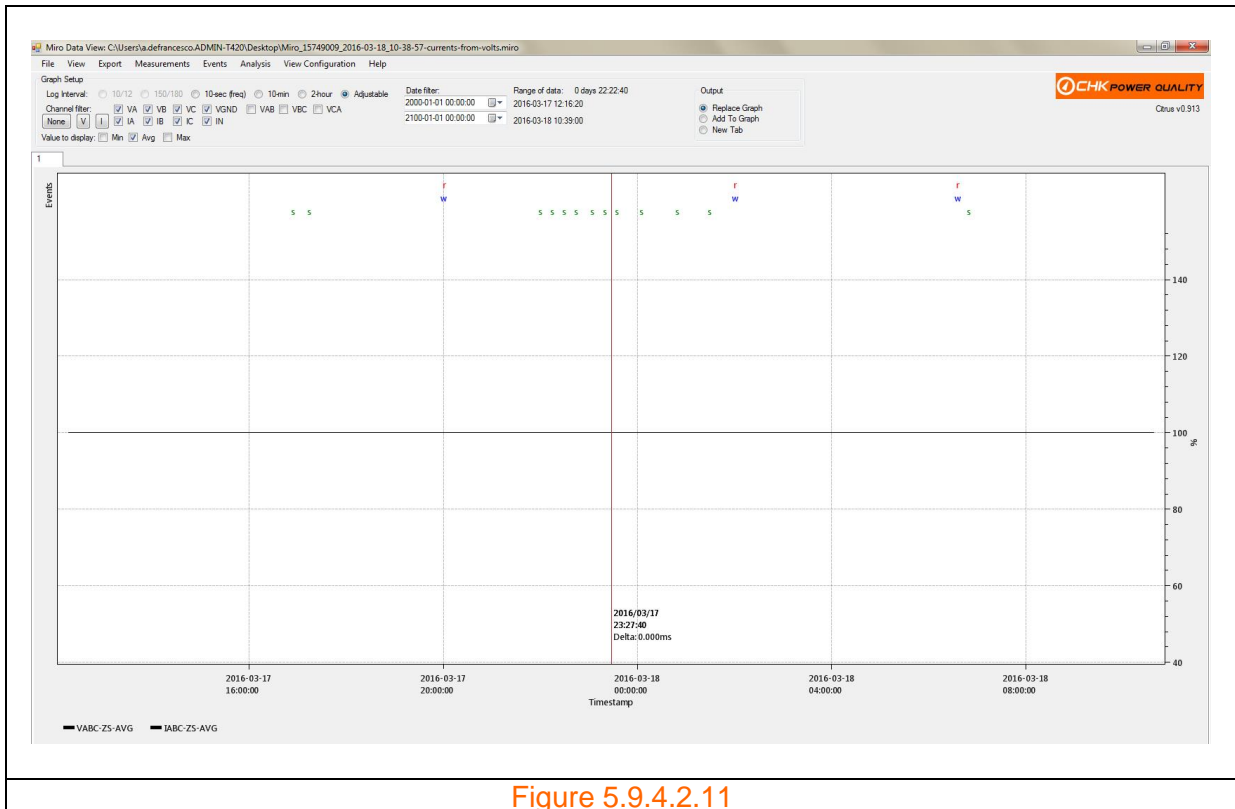

Figure 5.9.4.2.9

Clicking on 'Unbalance (Negative Sequence)' generates a graph displaying Unbalance due to negative sequencing as shown in figure 5.9.4.2.10.



Clicking on 'Unbalance (Zero Sequence)' generates a graph displaying Unbalance due to zero sequencing as shown in figure 5.9.4.2.11.



5.9.4.3 Harmonics

Clicking on 'Harmonics' in the 'Measurements' menu generates a sub menu listing 'Harmonic Magnitude', 'Harmonic Phase', 'Interharmonic Magnitude' and 'THD' measures as shown in figure 5.9.4.3.1.

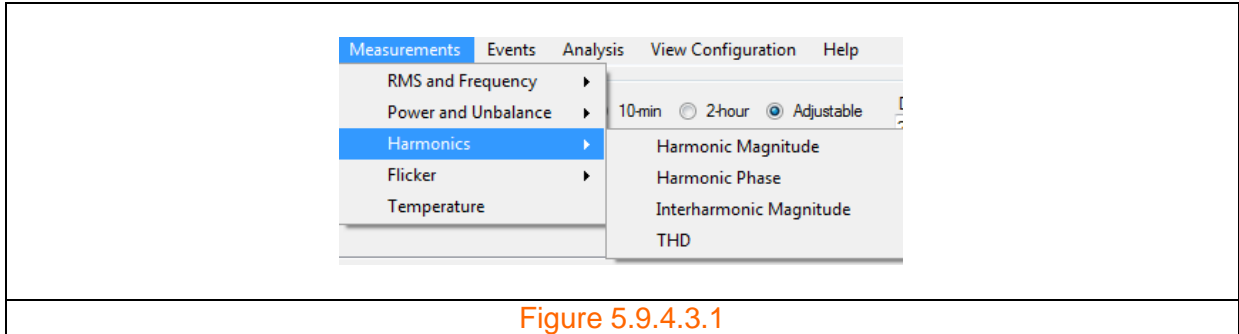

Figure 5.9.4.3.1

Clicking on 'Harmonic Magnitude' generates another form with checkboxes to select up to 100 harmonics as shown in figure 5.9.4.3.2. The form also provides option buttons to select harmonic groups as shown in figure 5.9.4.3.3.

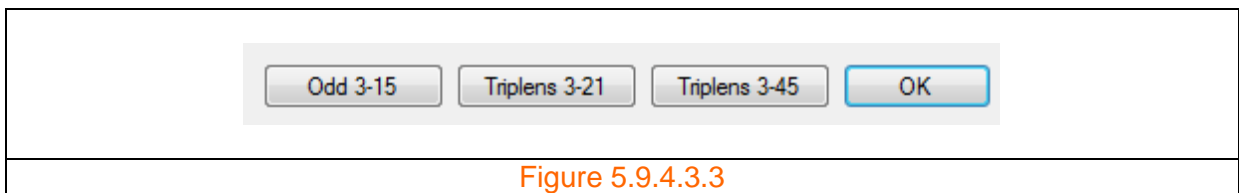

Figure 5.9.4.3.3

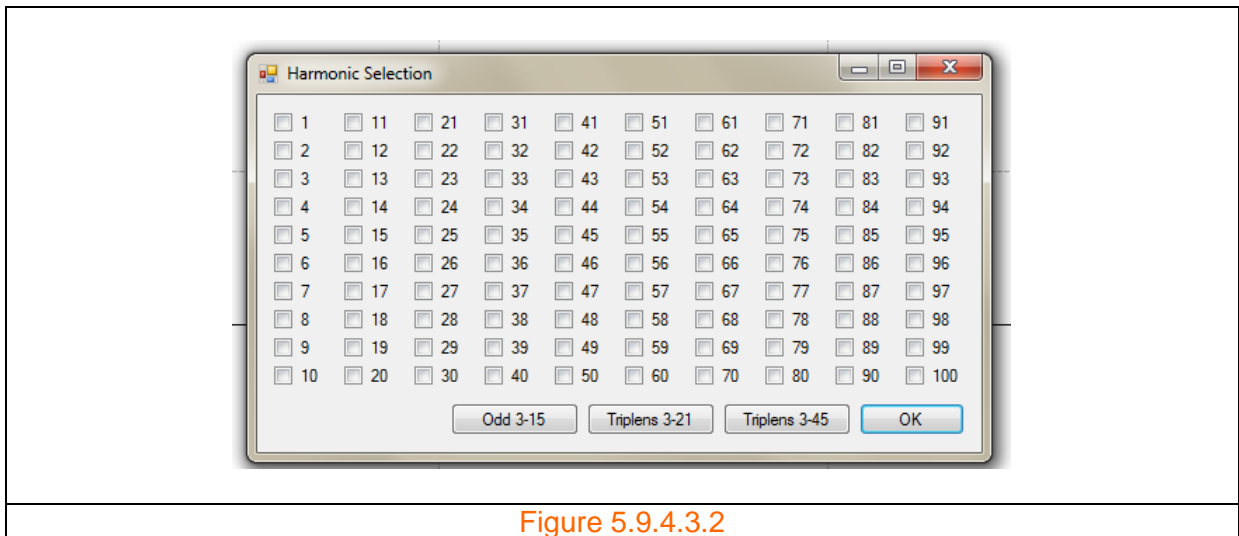

Figure 5.9.4.3.2

Clicking on 'Harmonic Phase' generates another form with checkboxes to select up to 50 harmonics as shown in figure 5.9.4.3.4. The form also provides option buttons to select harmonic groups as shown in figure 5.9.4.3.3.

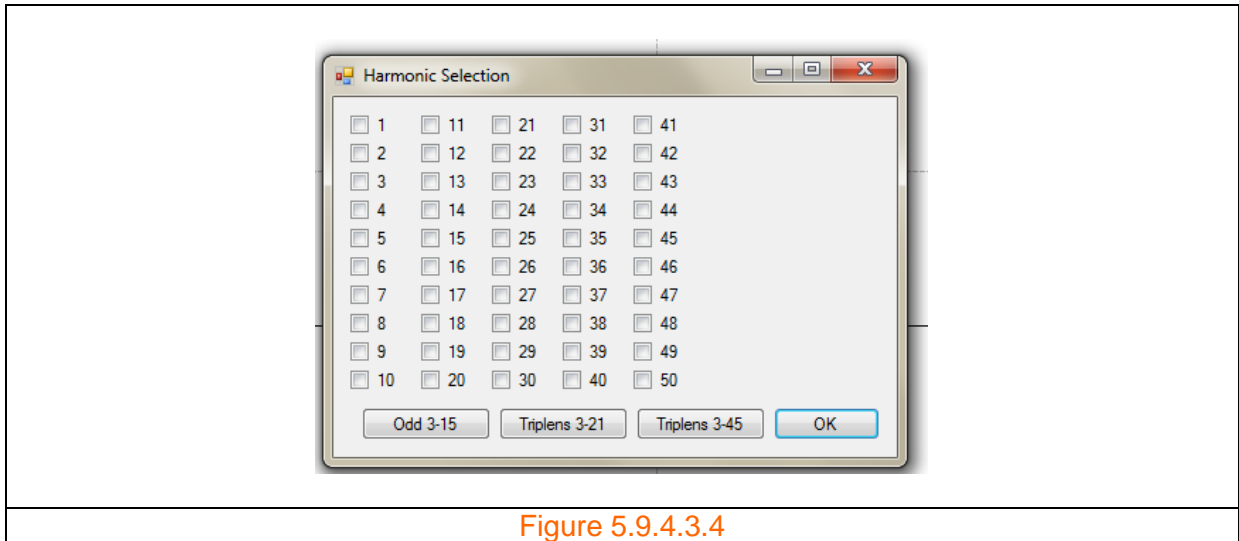

Figure 5.9.4.3.4

Clicking on 'Interharmonic Magnitude' generates another form with checkboxes to select up to 100 harmonics as shown in figure 5.9.4.3.5.

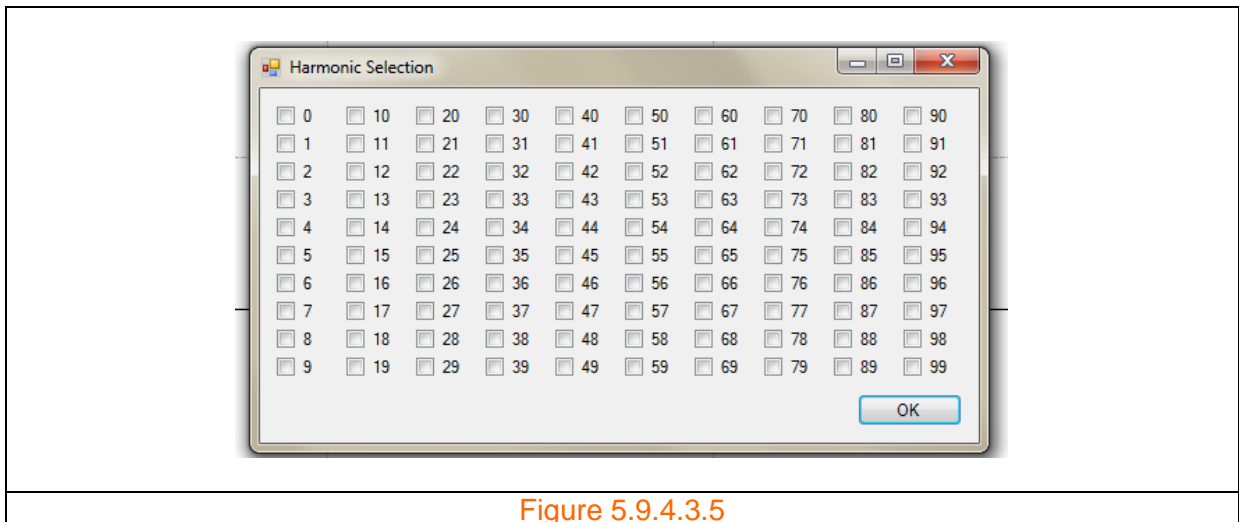
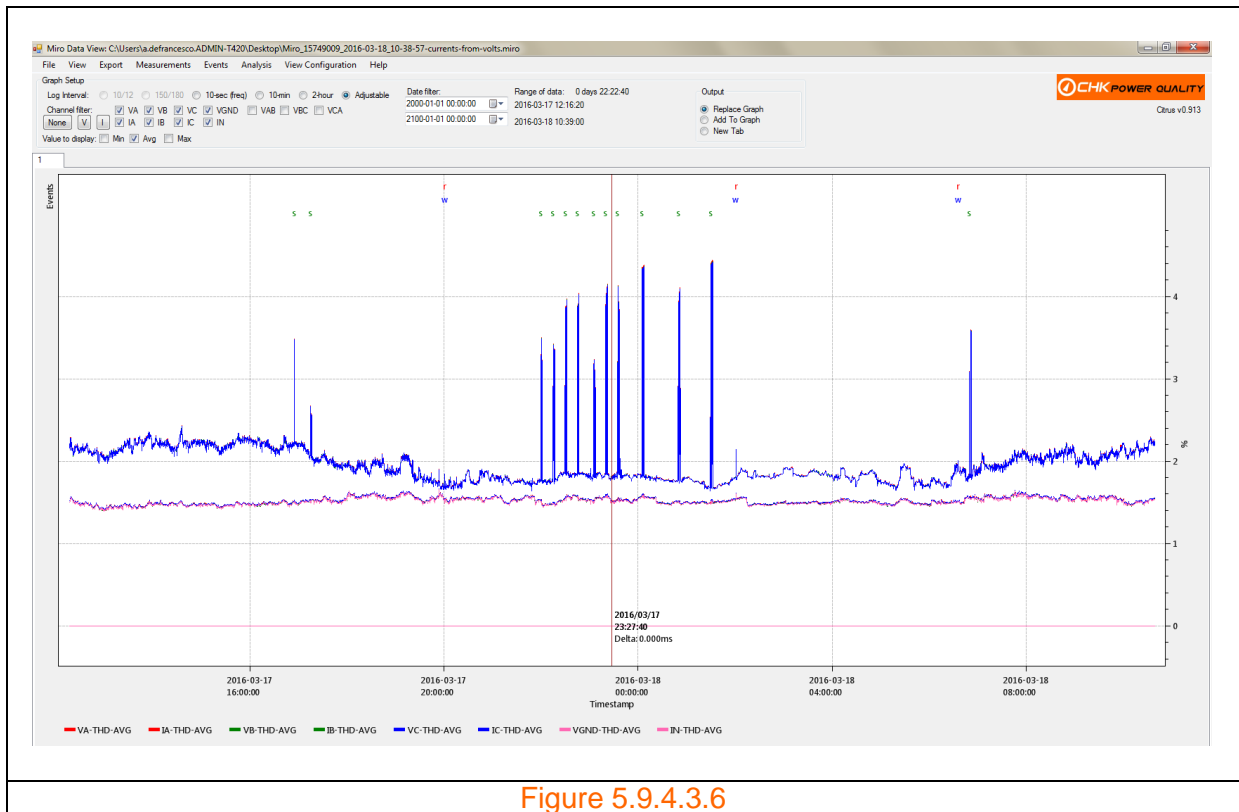

Figure 5.9.4.3.5

Clicking on 'THD' generates a graph as shown in figure 5.9.4.3.6.



5.9.4.4 Flicker

Clicking on 'Flicker' in the 'Measurements' menu generates a sub menu listing 'Short term (Pst)' and 'Long term (Plt)' flicker indices as shown in figure 5.9.4.4.1.

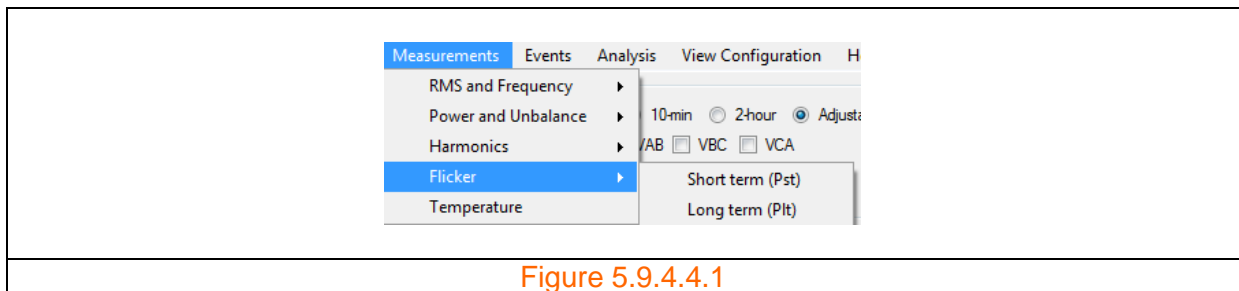

Clicking on 'Short term (Pst)' and 'Long term (Plt)' yields graphs as shown in figures 5.9.4.4.2 and 5.9.4.4.3 respectively.

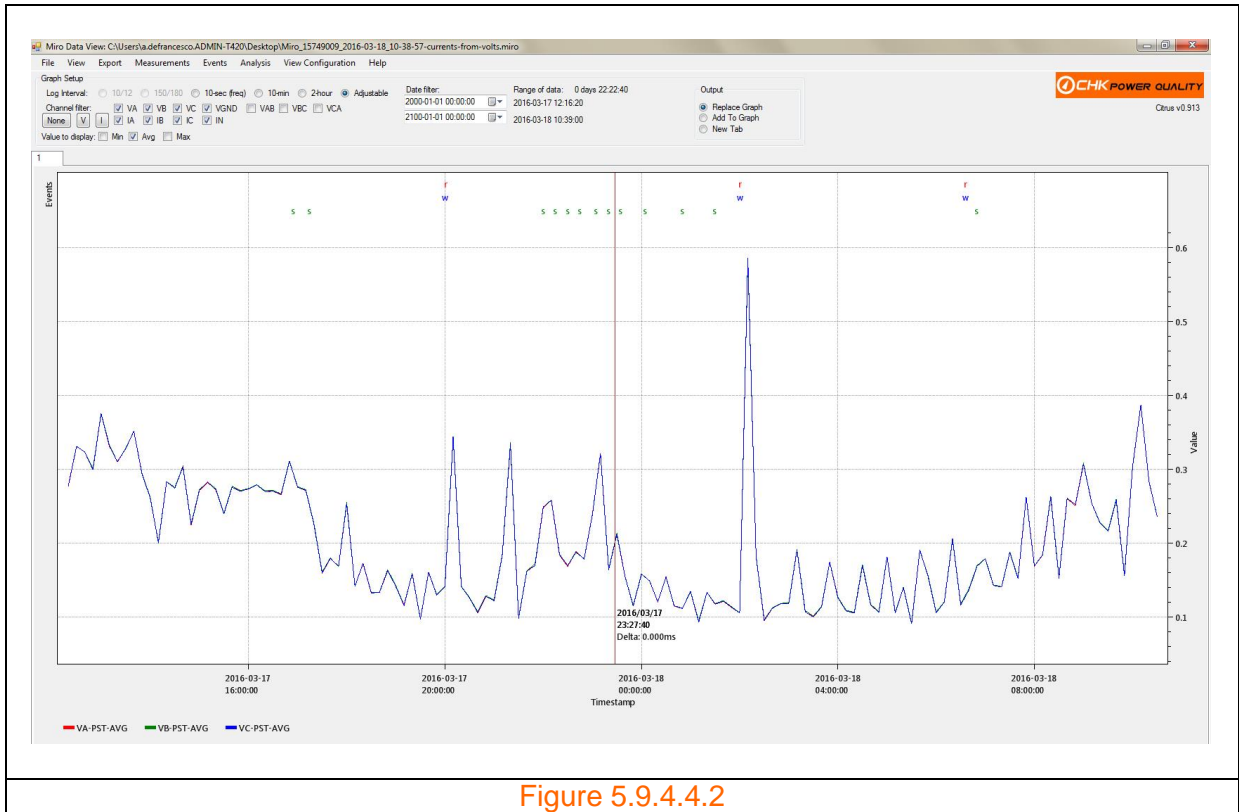

The index is a dimensionless number and displayed on the right hand side of the graph.

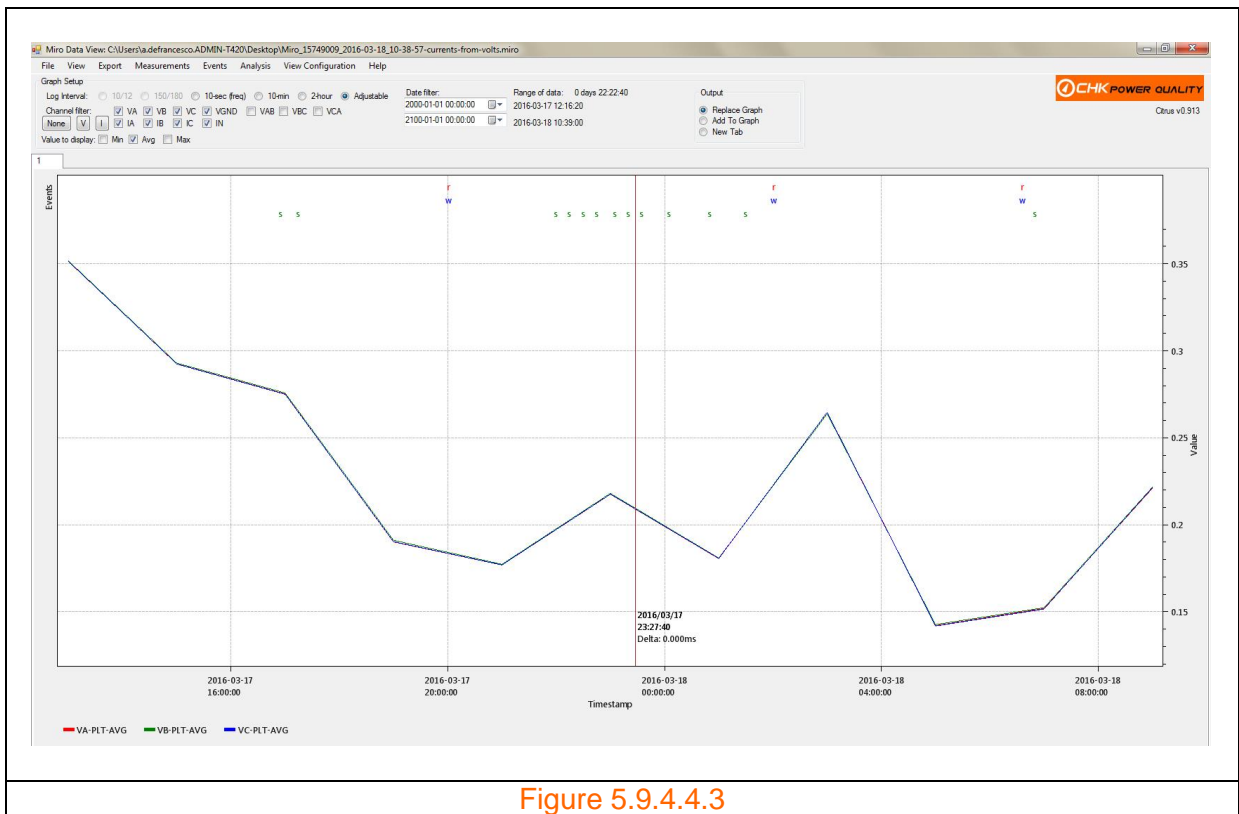

The index is a dimensionless number and displayed on the right hand side of the graph.

5.9.4.5 Temperature

Clicking on 'Temperature' in the 'Measurements' menu generates a graph as shown in figure 5.9.4.5.1.



The temperature values are in degrees Celsius and displayed on the right hand side of the graph.

If no temperature values are logged then a message box appears as shown in figure 5.9.4.5.2.

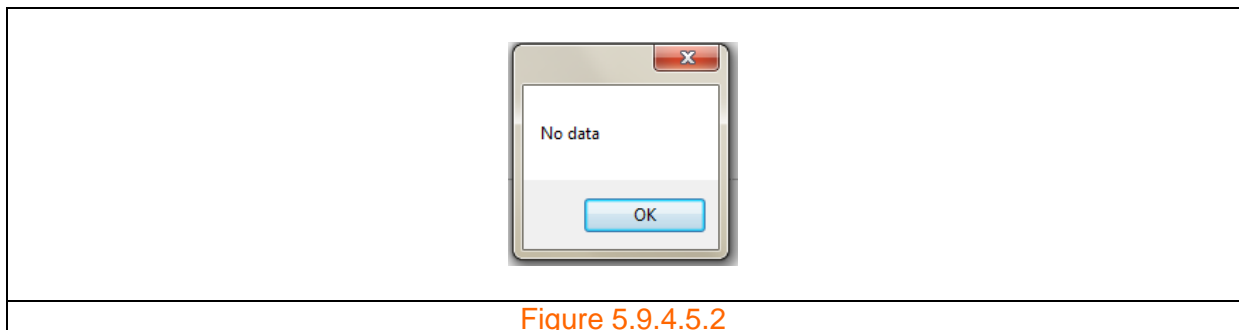

5.9.5 Events

Clicking on 'Events' opens the 'Event' form as shown in figure 5.9.5.1. The list box on the left hand side is populated with all the events.

Clicking an event in the list box will: (a) highlight the selected event; (b) automatically generate a chart on 'Event Graph'; and (c) display details about the event above the chart as shown in figure 5.9.5.2. Note that only waveform events will generate a graph.

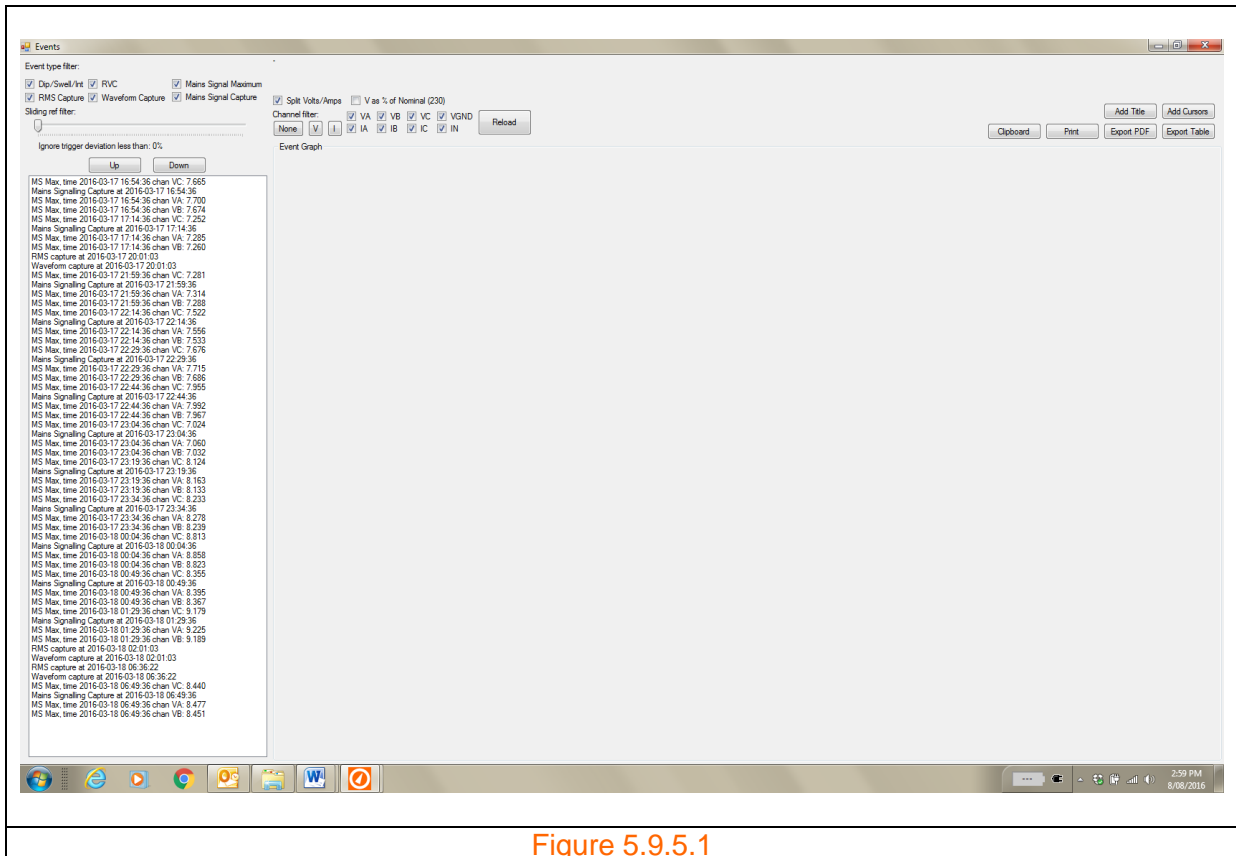

Figure 5.9.5.1

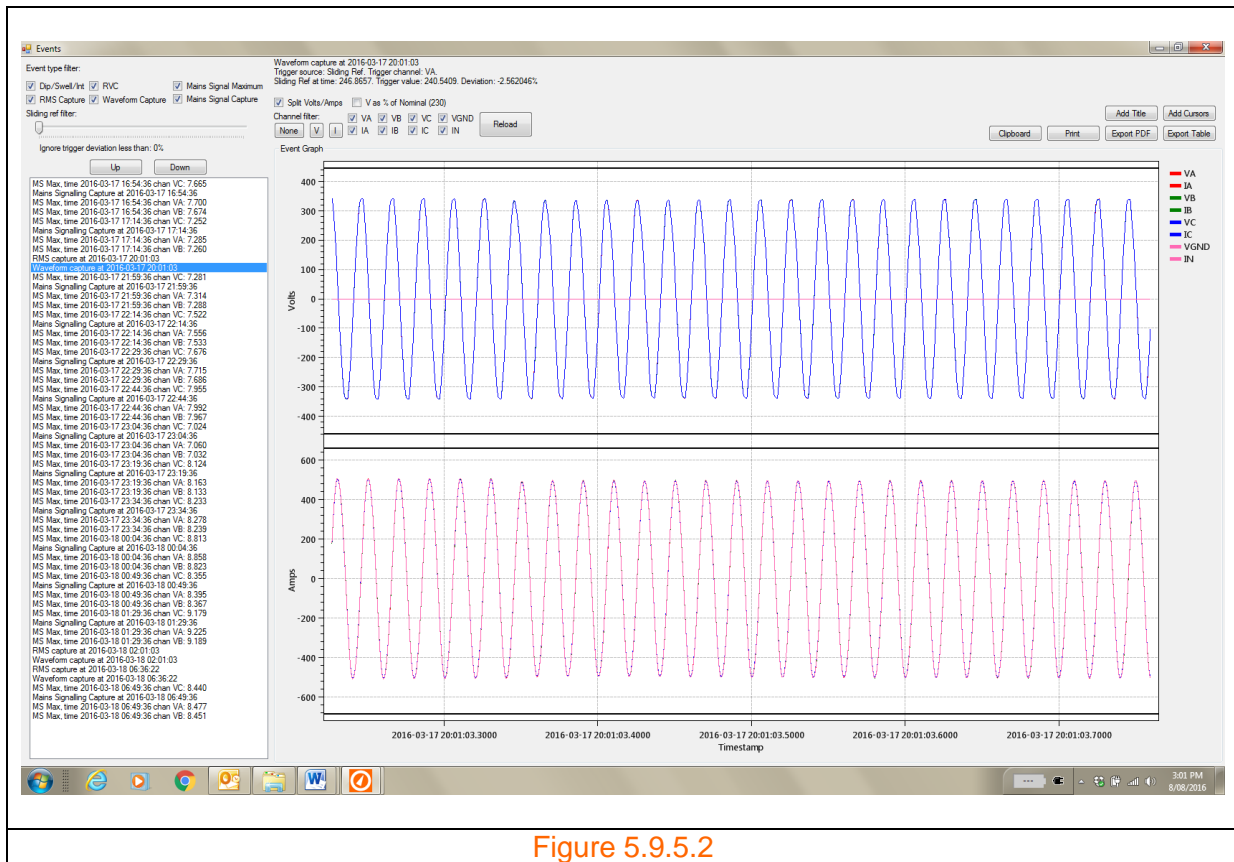

Figure 5.9.5.2

5.9.5.1 Event filters

Two event filters provided: (a) Check box event type filters; and (b) Sliding reference filter (minimum deviation control slider).

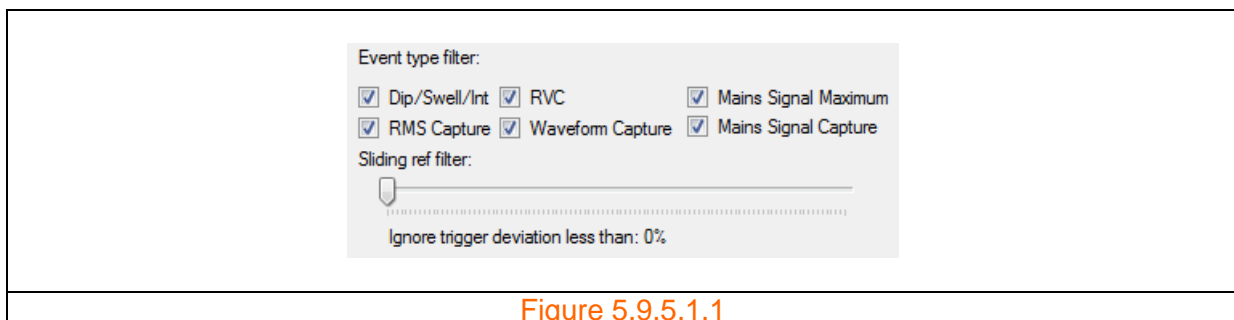

Figure 5.9.5.1.1

Check box event type filter

The checkbox type include: 'Dip/Swell/Int'; 'RMS Capture'; 'RVC'; 'Waveform Capture'; 'Mains Signal Maximum'; and 'Mains Signal Capture'.

The checkboxes allow the user to restrict the visibility of events and hence reduce the events populated in the list box as shown in figure 5.9.5.1.2.

Sliding reference filter

The sliding reference include: 'Dip/Swell/Int'; 'RMS Capture'; 'RVC'; 'Waveform Capture'; 'Mains Signal Maximum'; and 'Mains Signal Capture'.

The sliding reference minimum deviation control slider allows the user to filter out events below the minimum percent deviation from the reference value.

An example is shown in figure 5.9.5.1.3 where the slider is set to a sliding reference minimum deviation of 2.8%. The deviation of the event is 3.98106 % as shown in figure 5.9.5.1.4.

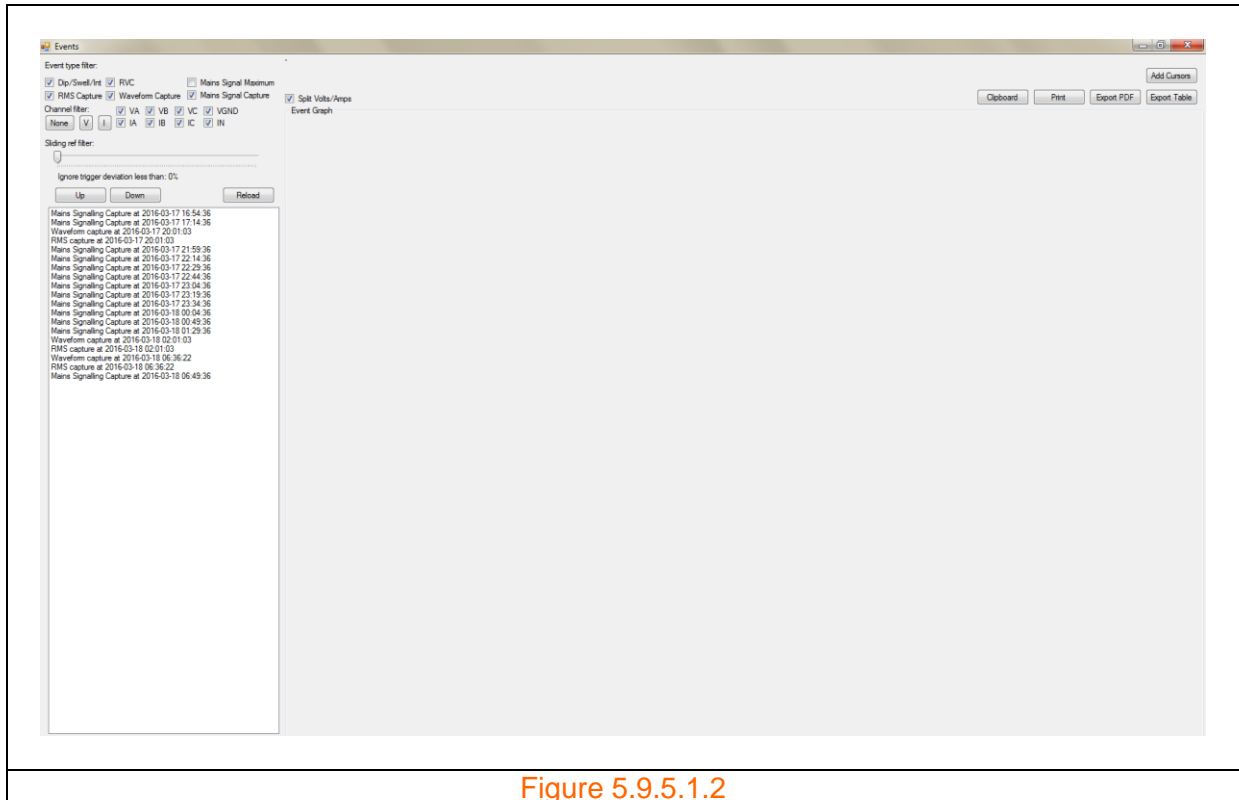

Figure 5.9.5.1.2

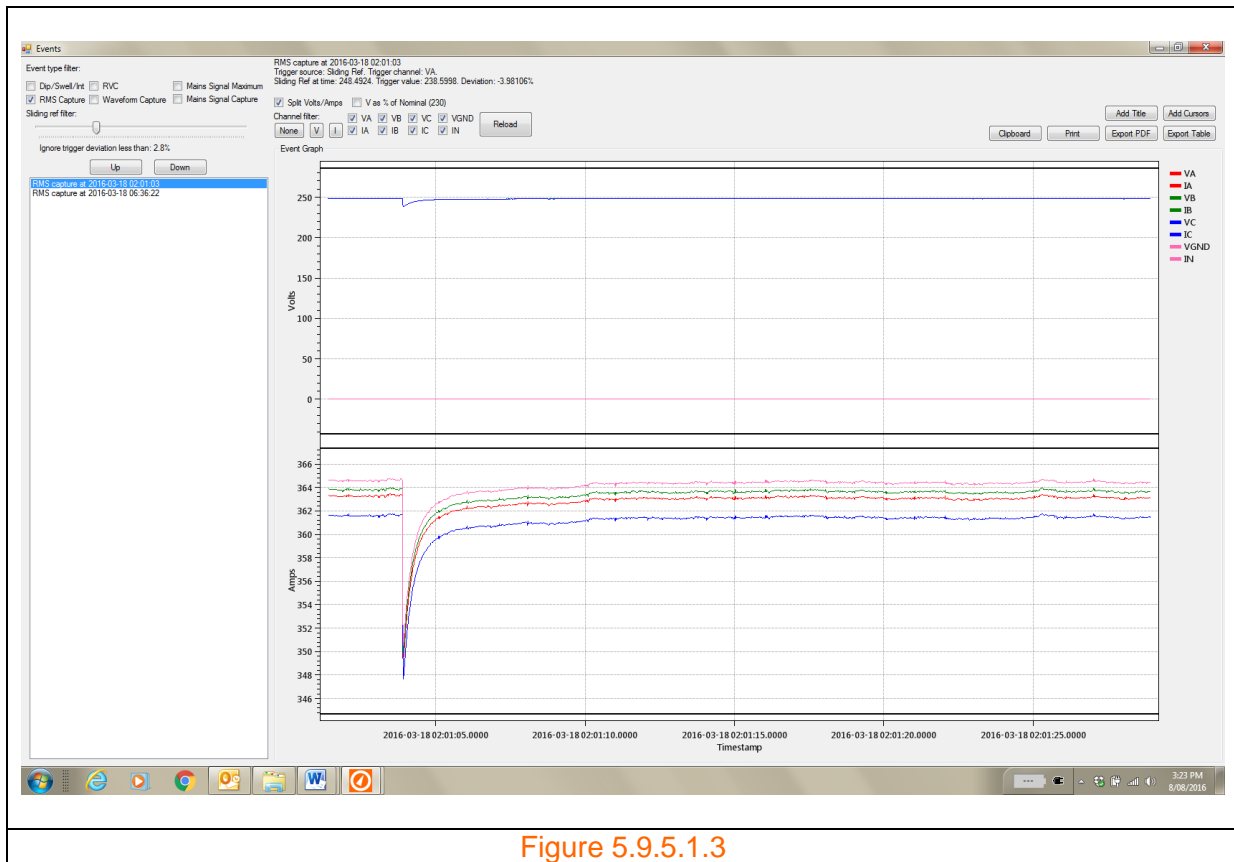

Figure 5.9.5.1.3

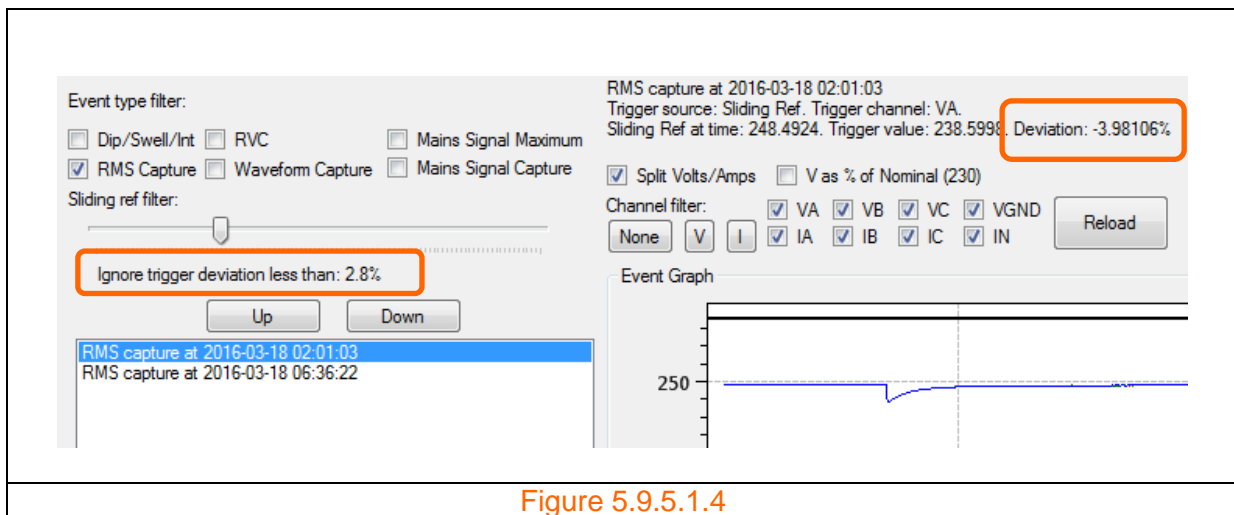

Figure 5.9.5.1.4

5.9.5.2 Event selection via up /down buttons

The 'Up' and 'Down' buttons shown in figures 5.9.5.2.1 and 5.9.5.2.2 allow the next event selection to be above or below the current selection.

5.9.5.4 Trace selection

The user is able to remove or add any trace from the graph by repeatedly clicking on the trace legend. The legend of deselected traces changes to a faint grey. Figure 5.9.5.4.1 shows only phase A voltage and current traces.

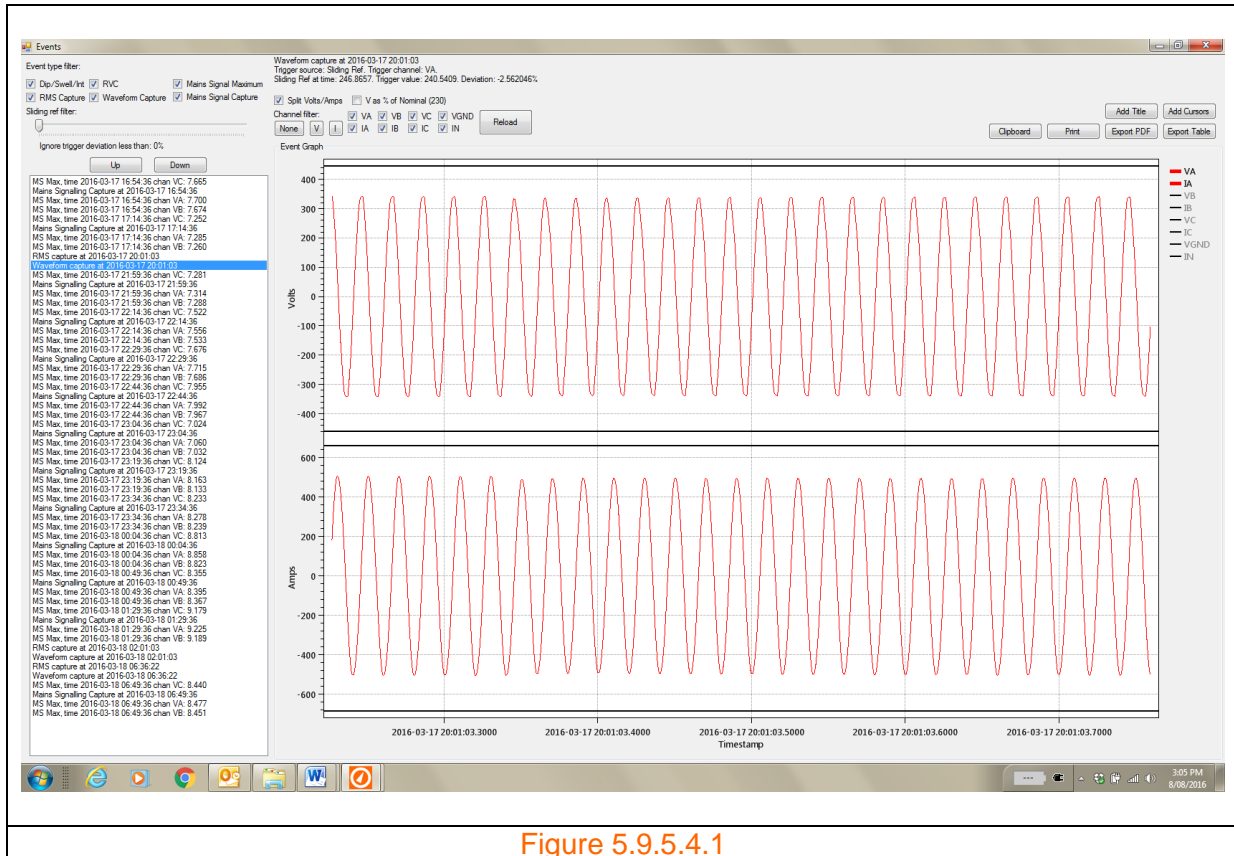

Figure 5.9.5.4.1

5.9.5.5 Reload button

The 'Reload' button updates the graph to the default selected event graph without having to reselect the event. This feature allows the user to quickly update the graph after visual configurational changes.

5.9.5.6 Voltage as % of nominal

The voltage axis can be scaled as voltage amplitude or as a percentage of the nominal voltage depending upon the setting of the 'V as % of Nominal (230)' checkbox as illustrated by figures 5.9.5.6.1 and 5.9.5.6.2. The number in the brackets reflects the setting for the nominal voltage. In this case it is 230V.

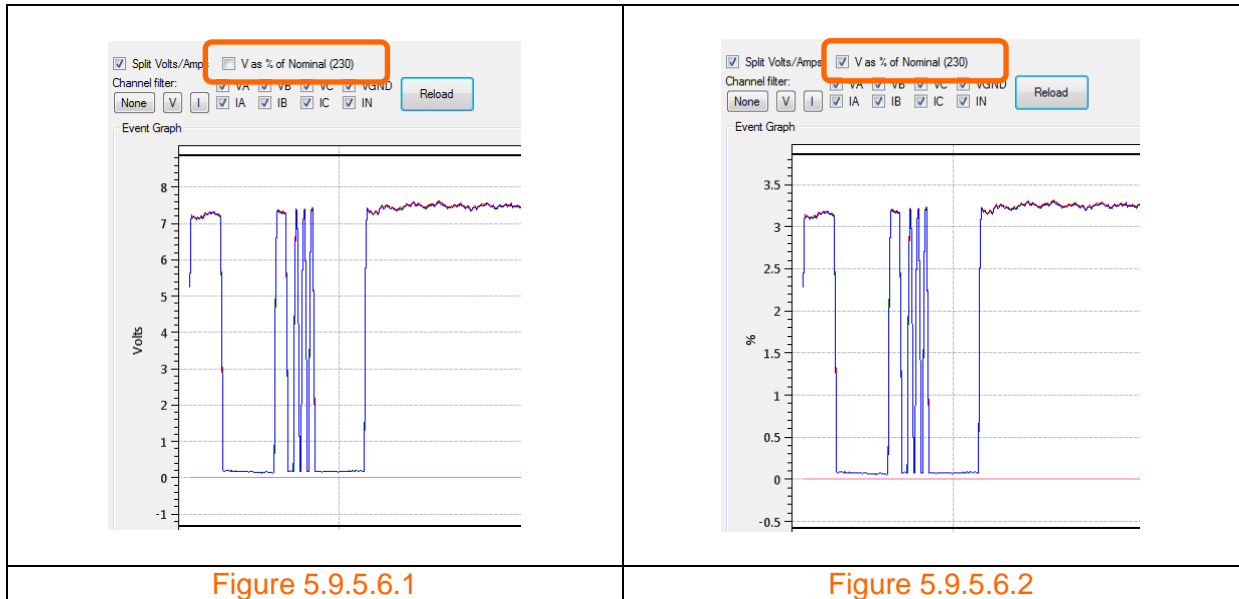

5.9.5.7 Add title

The user is able to insert a title on the event graph.

Step 1: Click the 'Add Title' button shown in figure 5.9.5.7.1.

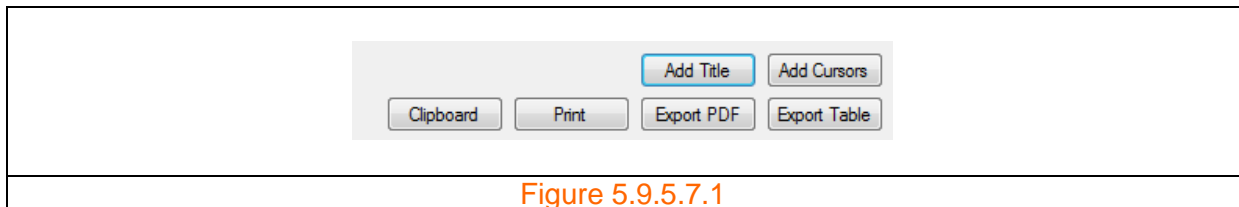

A drop down box appears as shown in figure 5.9.5.7.2. Enter text. As shown in figure 5.9.5.7.3. 'Mains signalling' is entered in this example.

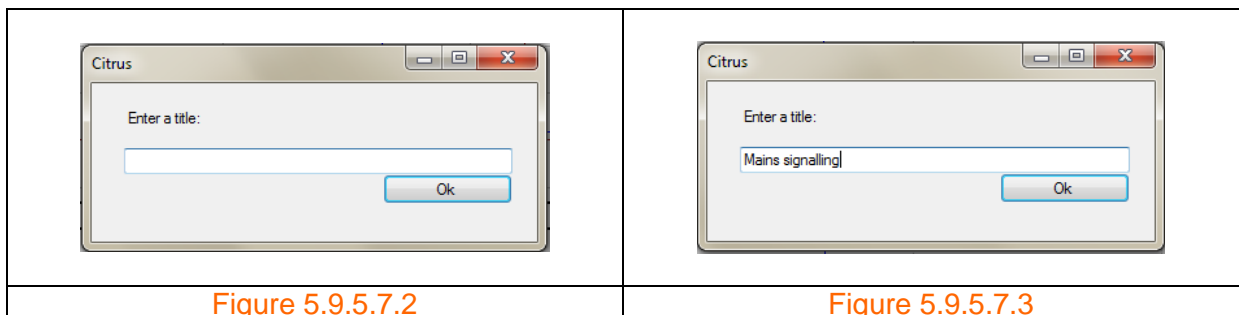

Step 2: Click on the 'OK' button. The entered text now appears as the title as shown in figure 5.9.5.7.4.

Removing a title

Clicking the 'Reload' button removes the title.

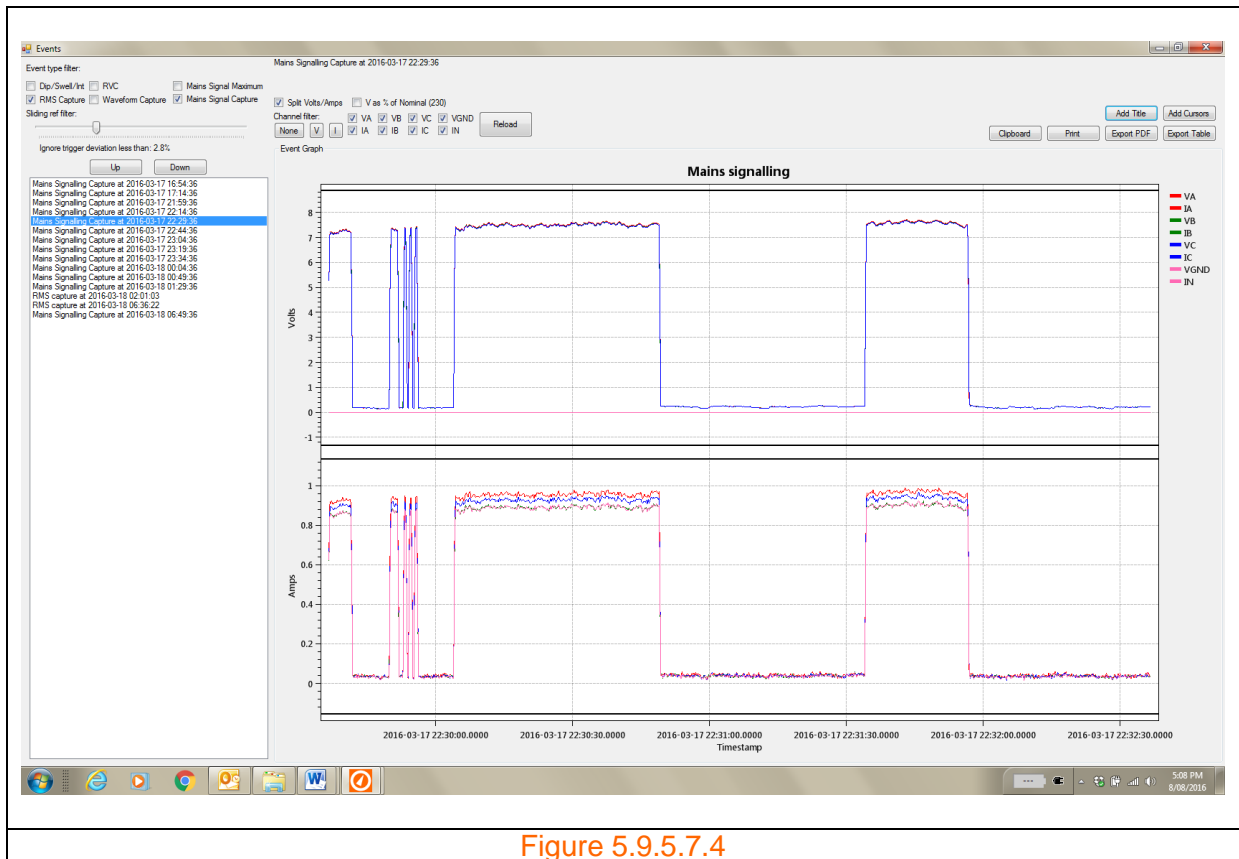

5.9.5.8 Add cursors

The 'Add Cursors' button generates a set of horizontal and vertical cursors on the graphs as shown in figure 5.9.5.8.1. Clicking the 'Reload' button removes the cursors.

The user is able to continuously add a new set of cursors on the graph by clicking the 'Add Cursors' button.

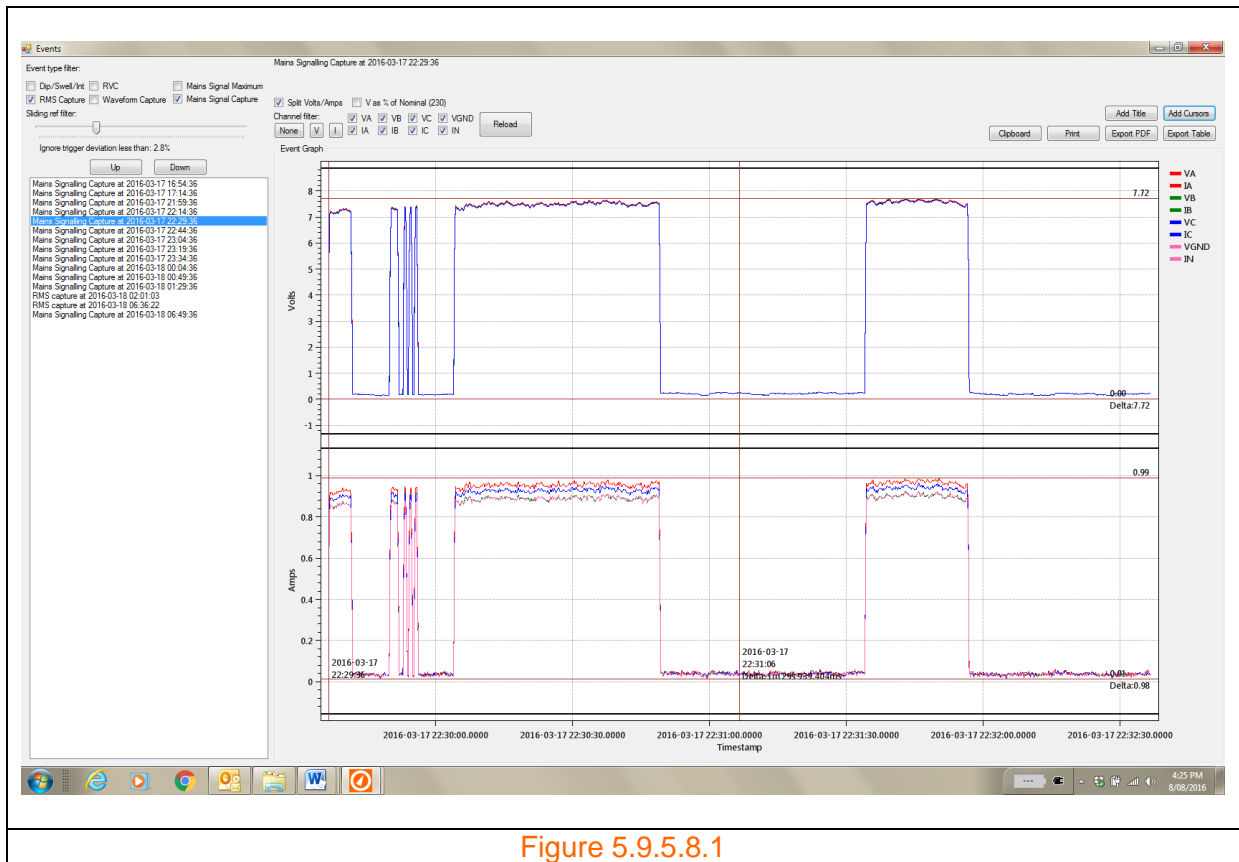

Figure 5.9.5.8.1

5.9.5.9 Clipboard

The 'Clipboard' button allows the user to save the event graph to the Clipboard.

Step 1: Click the 'Clipboard' button shown in figure 5.9.5.7.1. The graph is now saved to the clipboard.

5.9.5.10 Print

The user is able to print the event graph using the 'Print' function.

Step 1: Click the 'Print' button shown in figure 5.9.5.7.1. The printer setup form appears as shown in figure 5.9.5.10.1.

Step 2: Select the desired printer and preferences and then click on the 'Print' button.

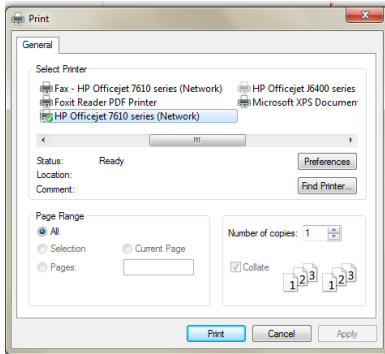

Figure 5.9.5.10.1

5.9.5.11 Export PDF

The user is able to convert the graph in to a PDF.

Step 1: Click the 'Export PDF' button shown in figure 5.9.5.7.1. A window opens as shown in figure 5.9.5.11.1 allowing the user to enter a file name and save to a particular folder. Enter a filename and click 'Save'.

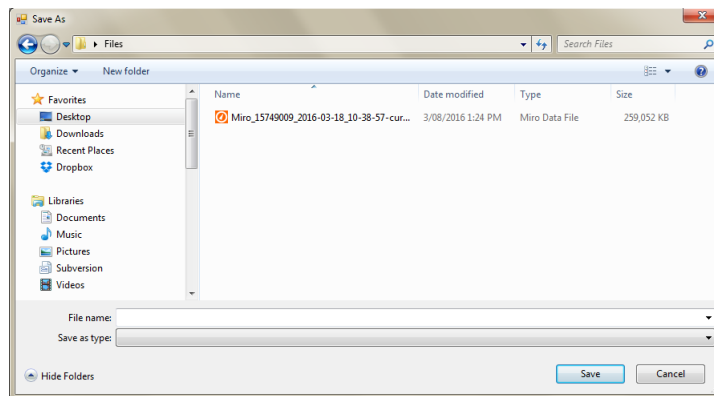

Figure 5.9.5.11.1

As shown in figure 5.9.5.11.2 the user can verify that the PDF file has been saved by viewing the files in the folder where the PDF was saved.

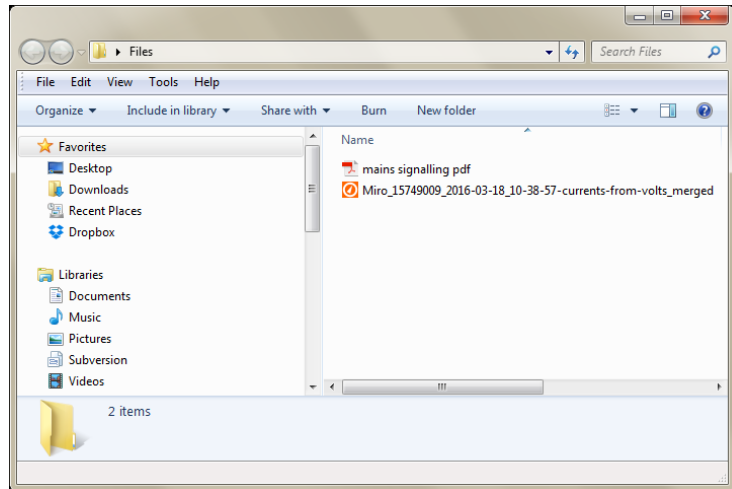

Figure 5.9.5.11.2

Step 2: Click on the saved .PDF. The example .PDF is shown in figure 5.9.5.11.3.

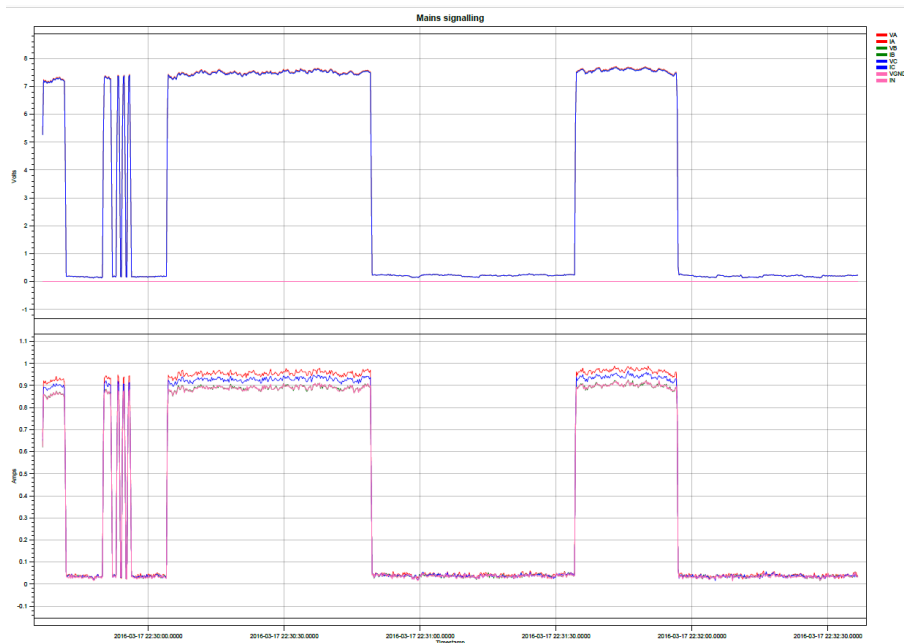

Figure 5.9.5.11.3

5.9.5.12 Export table

The 'Export Table' button generates a table of values for the graphical view.

For example in figure 5.9.5.12.1 a 'Mains Signalling Capture' event is highlighted and a graph generated. The user can then click on the 'Export Table' button to generate the table shown in figure 5.9.5.12.2.

If no event is selected and no view generated, then no table will be generated if the user clicks the 'Export Table' button.

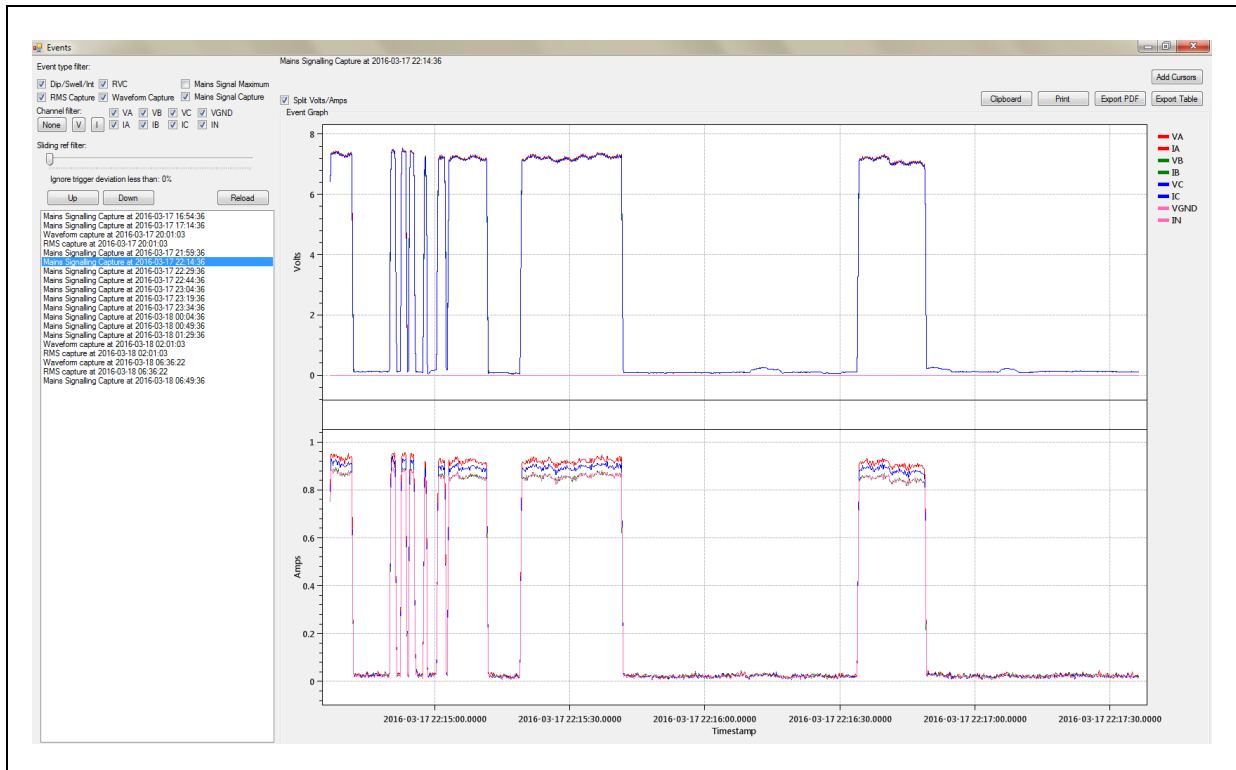

Figure 5.9.5.12.1

The screenshot shows the 'Data Table' window, which displays a table of power quality data. The table has the following columns: Timestamp, VA, IA, VB, IB, VC, IC, VGND, and IN. The data is organized into rows, with the first row highlighted in blue. The table contains 17 rows of data, showing various power quality parameters over time.

Timestamp	VA	IA	VB	IB	VC	IC	VGND	IN
2016-03-17 22:14:36.7741	6.436	0.814	6.415	0.752	6.407	0.793	0.000	0.754
2016-03-17 22:14:36.9739	7.378	0.951	7.346	0.882	7.343	0.929	0.000	0.881
2016-03-17 22:14:37.1736	7.374	0.942	7.346	0.880	7.339	0.916	0.000	0.884
2016-03-17 22:14:37.3734	7.362	0.935	7.337	0.867	7.328	0.903	0.000	0.867
2016-03-17 22:14:37.5732	7.434	0.952	7.408	0.888	7.400	0.921	0.000	0.886
2016-03-17 22:14:37.7730	7.369	0.938	7.343	0.877	7.332	0.918	0.000	0.881
2016-03-17 22:14:37.9727	7.439	0.947	7.408	0.893	7.400	0.929	0.000	0.885
2016-03-17 22:14:38.1725	7.434	0.945	7.407	0.884	7.394	0.919	0.000	0.881
2016-03-17 22:14:38.3723	7.384	0.934	7.358	0.869	7.348	0.904	0.000	0.871
2016-03-17 22:14:38.5721	7.442	0.942	7.411	0.889	7.404	0.922	0.000	0.880
2016-03-17 22:14:38.7718	7.349	0.937	7.323	0.867	7.310	0.911	0.000	0.870
2016-03-17 22:14:38.9716	7.330	0.916	7.303	0.860	7.292	0.893	0.000	0.857
2016-03-17 22:14:39.1714	7.366	0.939	7.338	0.871	7.327	0.909	0.000	0.875
2016-03-17 22:14:39.3712	7.292	0.922	7.264	0.859	7.258	0.902	0.000	0.862
2016-03-17 22:14:39.5710	7.345	0.934	7.320	0.867	7.307	0.910	0.000	0.871
2016-03-17 22:14:39.7707	7.306	0.926	7.281	0.865	7.272	0.902	0.000	0.869

Figure 5.9.5.12.2

5.9.6 Analysis

Clicking on the 'Analysis' menu button opens a submenu showing the current list of analyses that include: 'Harmonic Average'; 'Harmonic Compliance'; 'Voltage Compliance'; 'Energy'; 'Daily Min/Max'; and 'ITI (CBEMA) Curve' as shown in figure 5.9.6.1.

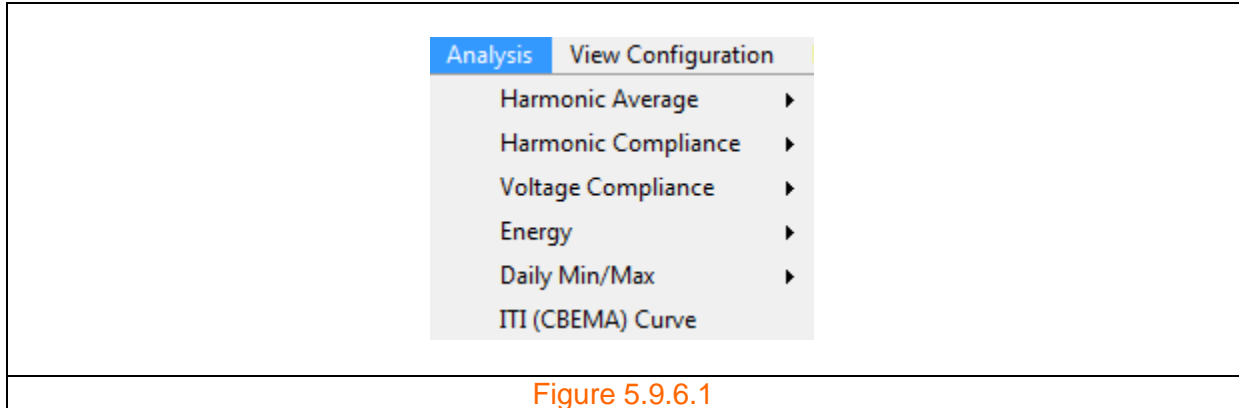

Figure 5.9.6.1

5.9.6.1 Harmonic average

Clicking on the 'Harmonic Average' button generates a sub menu, as shown in figures 5.9.6.1.1 and 5.9.6.1.2, with options to select graphs with amplitudes as percentage of fundamental or magnitude.

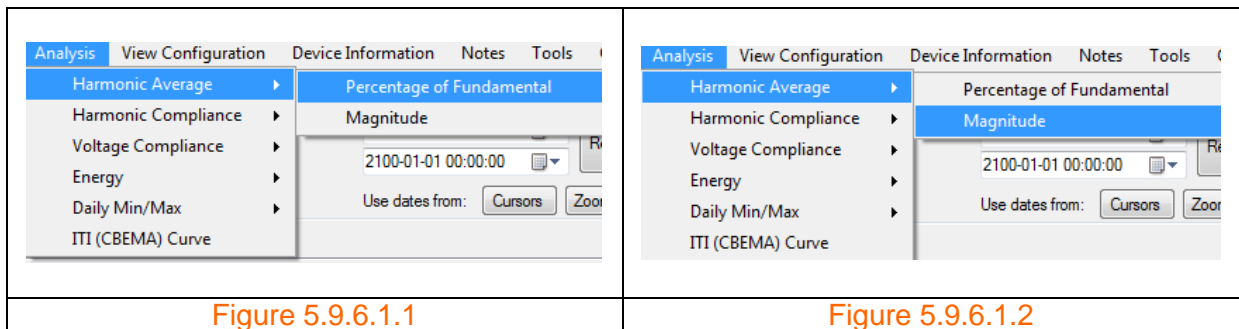

Figure 5.9.6.1.1

Figure 5.9.6.1.2

The respective graphs are shown in figures 5.9.6.1.3 and 5.9.6.1.4 which display voltage and current channels up to the 100th harmonic.

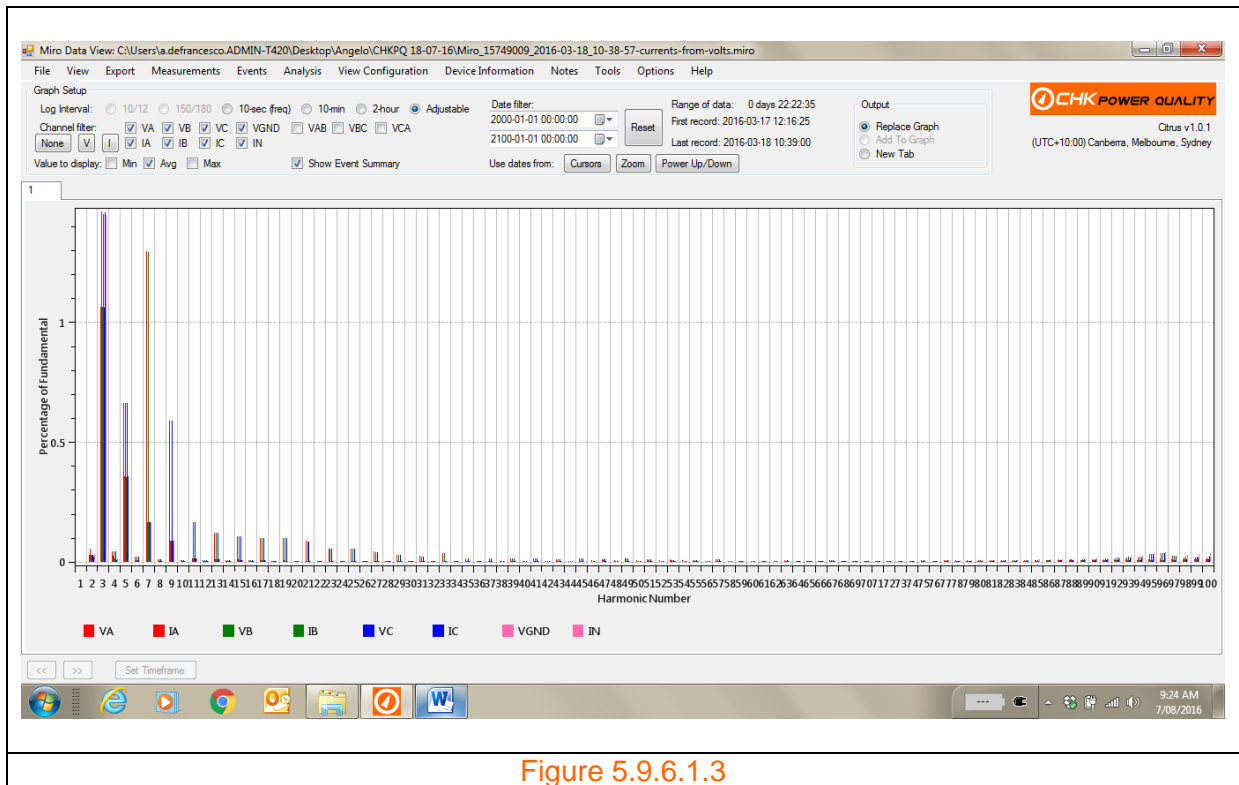

Figure 5.9.6.1.3

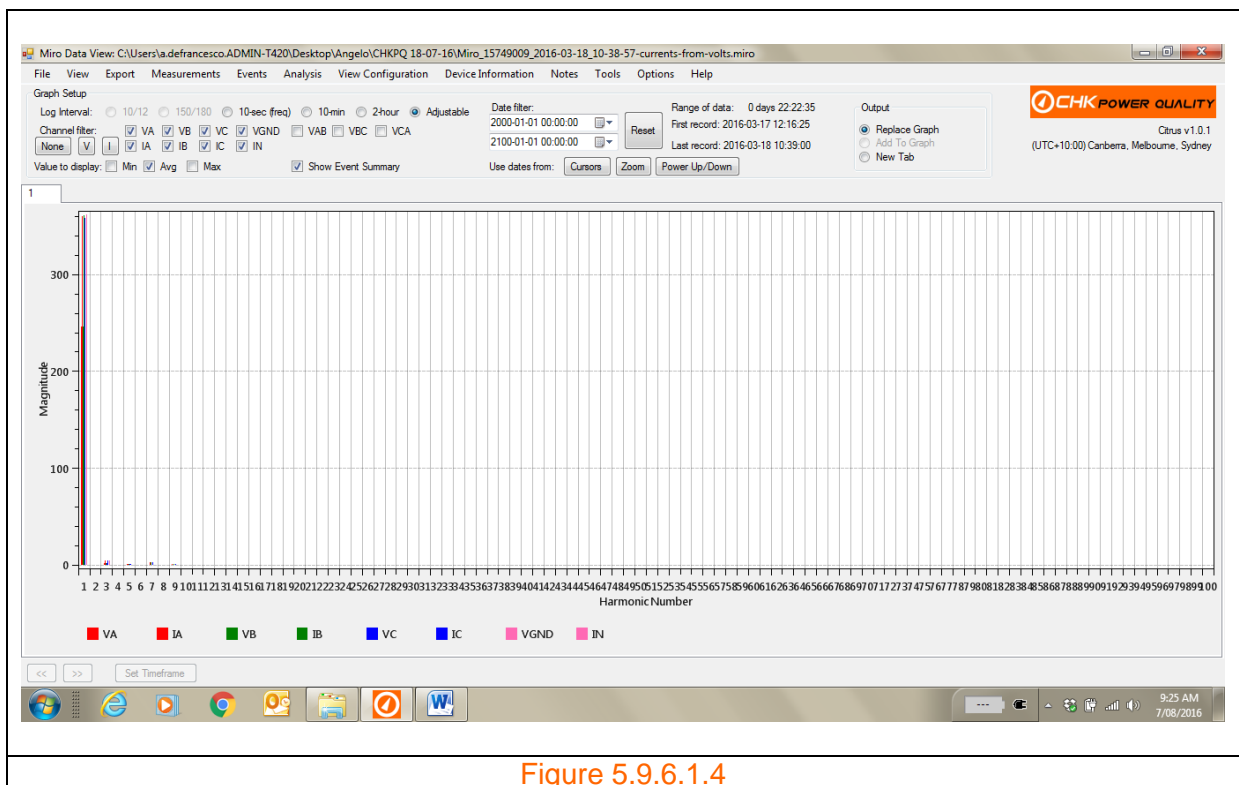

Figure 5.9.6.1.4

5.9.6.2 Harmonic compliance

Harmonic voltage

Clicking on the 'Harmonic Compliance' button generates a series of submenus, as shown in figures 5.9.6.2.1 and 5.9.6.2.2, with options to select voltage graphs with amplitudes as percentage of fundamental or proportion of compliance limits.

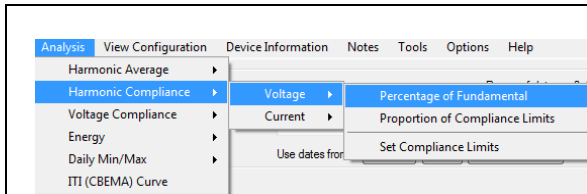

Figure 5.9.6.2.1

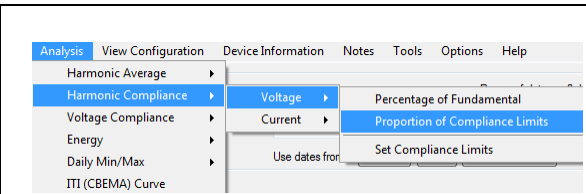

Figure 5.9.6.2.2

Clicking the 'OK' button in figure 5.9.6.2.2 generates the respective graphs shown in figures 5.9.6.2.3 and 5.9.6.2.4 which display the 95% percentile and 100% measurements of voltage harmonics for each channel up to the 50th harmonic.

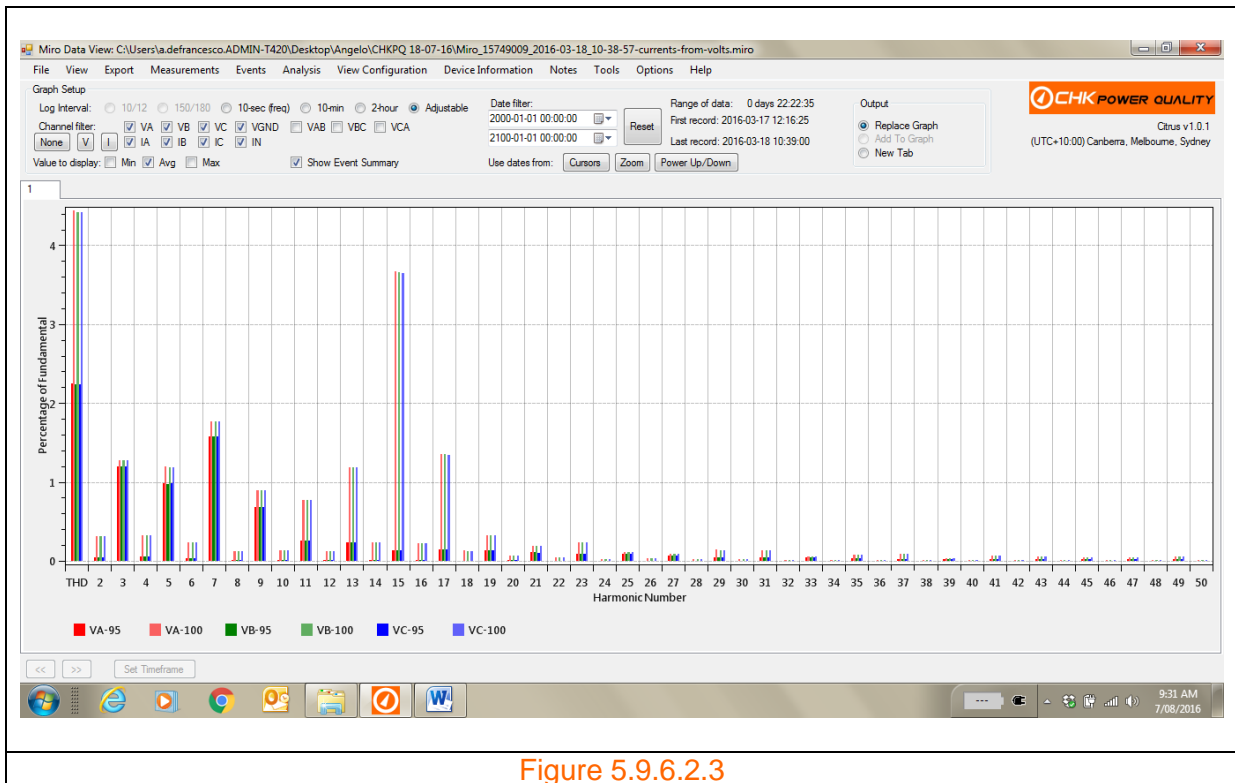
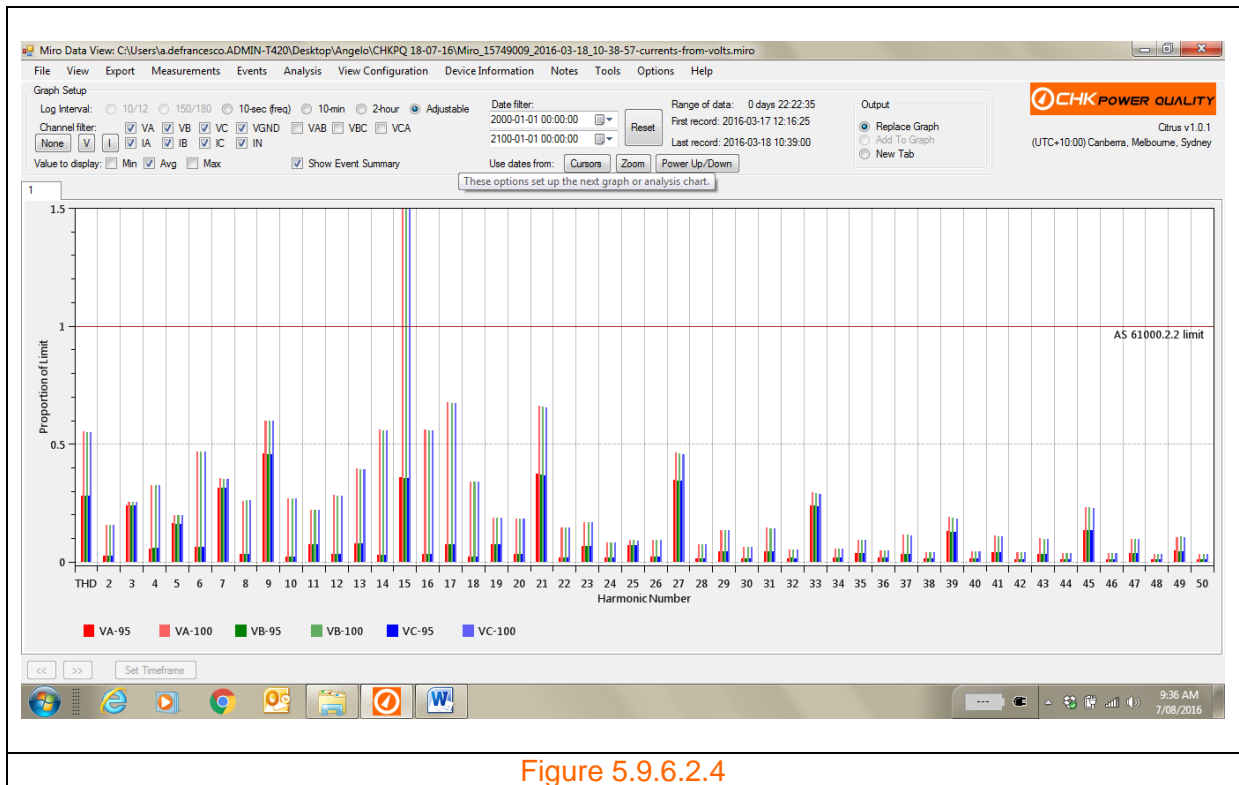

Figure 5.9.6.2.3



Harmonic voltage limits

Clicking on the 'Set Configuration Limits' as shown in figure 5.9.6.2.5 opens a form as shown in figure 5.9.6.2.6 that allows the user to alter the limits for each harmonic.

Figure 5.9.6.2.5

THD	H11	H12	H13	H14	H15	H16	H17	H18	H19	H20	H21	H22	H23	H24	H25	H26	H27	H28	H29	H30	H31	H32	H33	H34	H35	H36	H37	H38	H39	H40	H41	H42	H43	H44	H45	H46	H47	H48	H49	H50
8.000	3.500	2.000	5.000	1.000	6.000	0.500	5.000	0.500	1.500	0.500	0.300	0.364	1.408	0.354	1.274	0.346	0.200	0.339	1.061	0.333	0.975	0.328	0.200	0.324	0.833	0.319	0.773	0.316	0.200	0.313	0.671	0.310	0.627	0.307	0.200	0.304	0.551	0.302	0.518	0.300

Figure 5.9.6.2.6

Limits can also be loaded from two predefined standards that include AS61000.2.2 and IEEE519 table 10-3, or from a saved file.

Harmonic current

Clicking on the 'Harmonic Compliance' button generates a series of submenus, as shown in figures 5.9.6.2.7 and 5.9.6.2.8, with options to select current graphs with amplitudes as percentage of maximum demand or proportion of compliance limits.

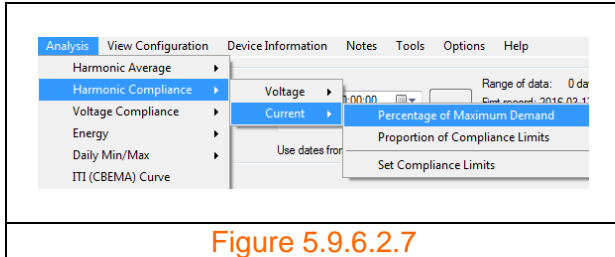

Figure 5.9.6.2.7

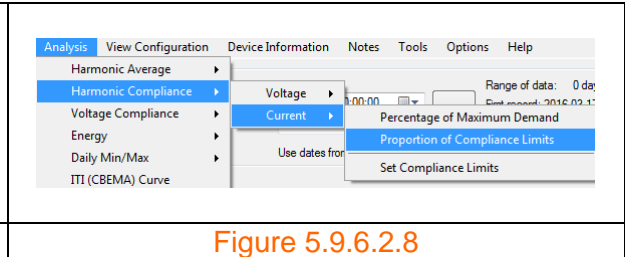

Figure 5.9.6.2.8

Clicking on the 'Percentage of Maximum Demand' button or the 'Proportion of Compliance Limit' button opens the input box shown in figure 5.9.6.2.9 prompting the user to enter a value for the maximum demand. For this example the value of 500A is entered as shown in figure 5.9.6.2.10.

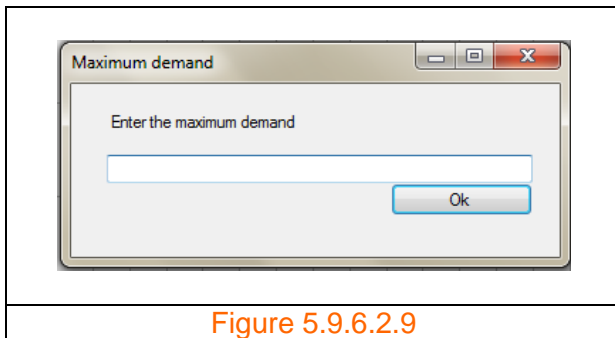

Figure 5.9.6.2.9

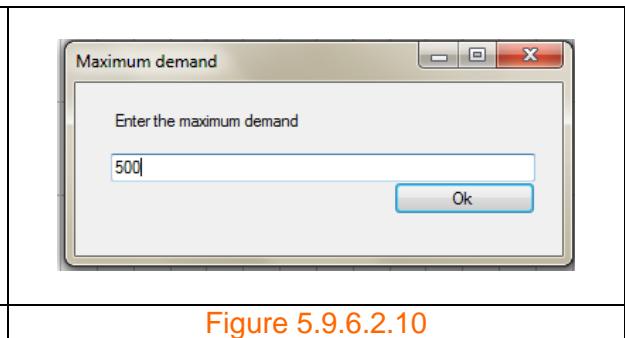
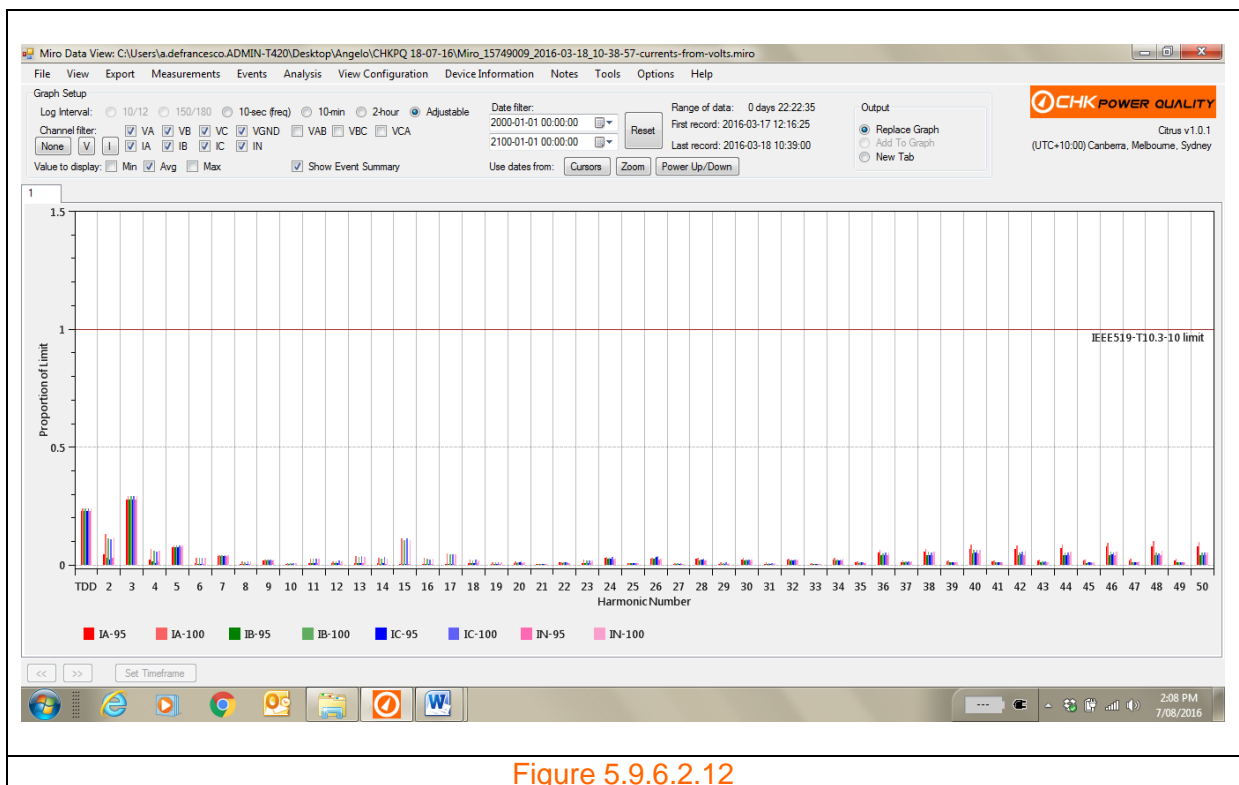
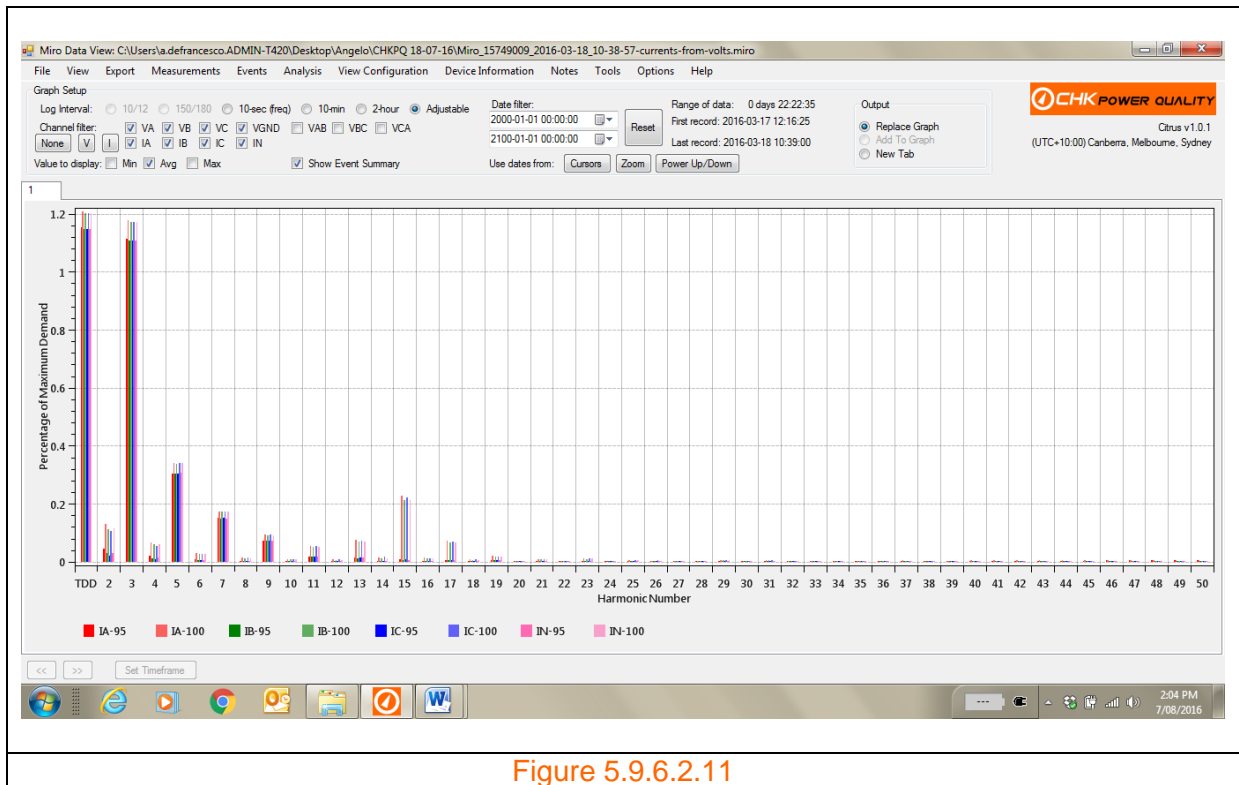

Figure 5.9.6.2.10

Clicking the 'OK' button in figure 5.9.6.2.10 generates the respective graphs shown in figures 5.9.6.2.11 and 5.9.6.2.12 which display the 95% percentile and 100% measurements of current harmonics for each channel up to the 50th harmonic.



Harmonic current limits

Clicking on the 'Set Configuration Limits' as shown in figure 5.9.6.2.13 opens a form as shown in figure 5.9.6.2.14 that allows the user to alter the limits for each harmonic.

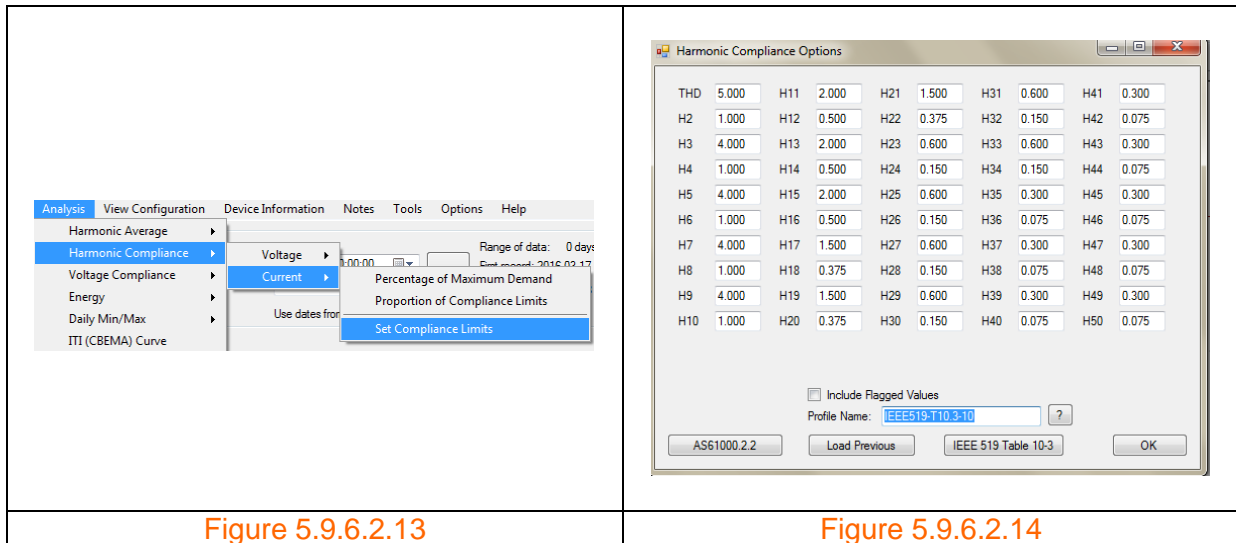

Figure 5.9.6.2.13

Figure 5.9.6.2.14

Limits can also be loaded from two predefined standards that include AS61000.2.2 and IEEE519 table 10-3, or from a saved file.

5.9.6.3 Voltage compliance

Clicking on the 'Voltage Compliance' button opens another submenu providing options to select either 'Setup', 'Percentile Table' or 'Histogram' as shown in figure 5.9.6.3.1.

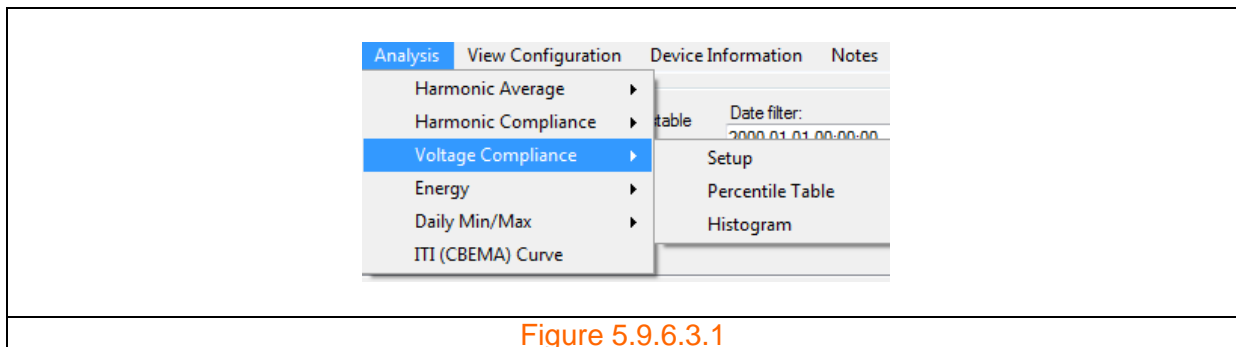

Figure 5.9.6.3.1

Clicking on the 'Setup' opens a form as shown in figure 5.9.6.3.2 that allows the user to alter the compliance parameters that affect the histogram and percentile tables.

The 'Lower bound' and the 'Upper bound' phase to neutral and phase to phase voltages sets the bin range on the x axis.

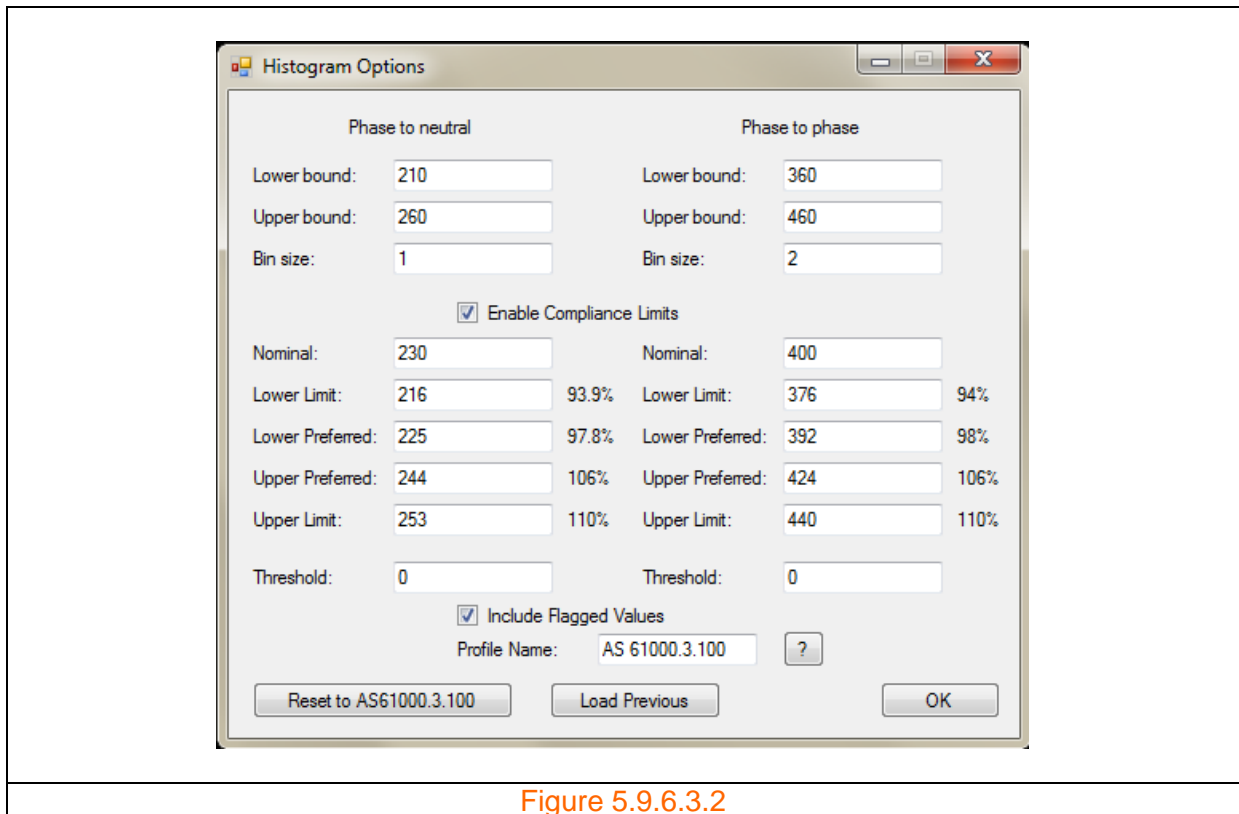

Figure 5.9.6.3.2

The voltage values for the 'Lower Limit', 'Upper Limit', 'Lower Preferred' and 'Upper Preferred' set the two regions on the graph.

The percentiles are calculated for voltages that exceed the 'Threshold' voltage and therefore useful in discarding from the analysis voltages below the threshold.

Clicking on the 'OK' button automatically saves the profile with the current 'Profile Name'. The user is able to load a profile by clicking on the 'Load Previous' button. A list box appears allowing the user to select a profile. The name of the selected profile appears to the right of the 'Profile Name' label.

As shown in figure 5.9.6.3.3 the 'Percentile Table' summaries key statistical metrics and indicate if the metrics are in or out of compliance (above or below the upper and lower limits).

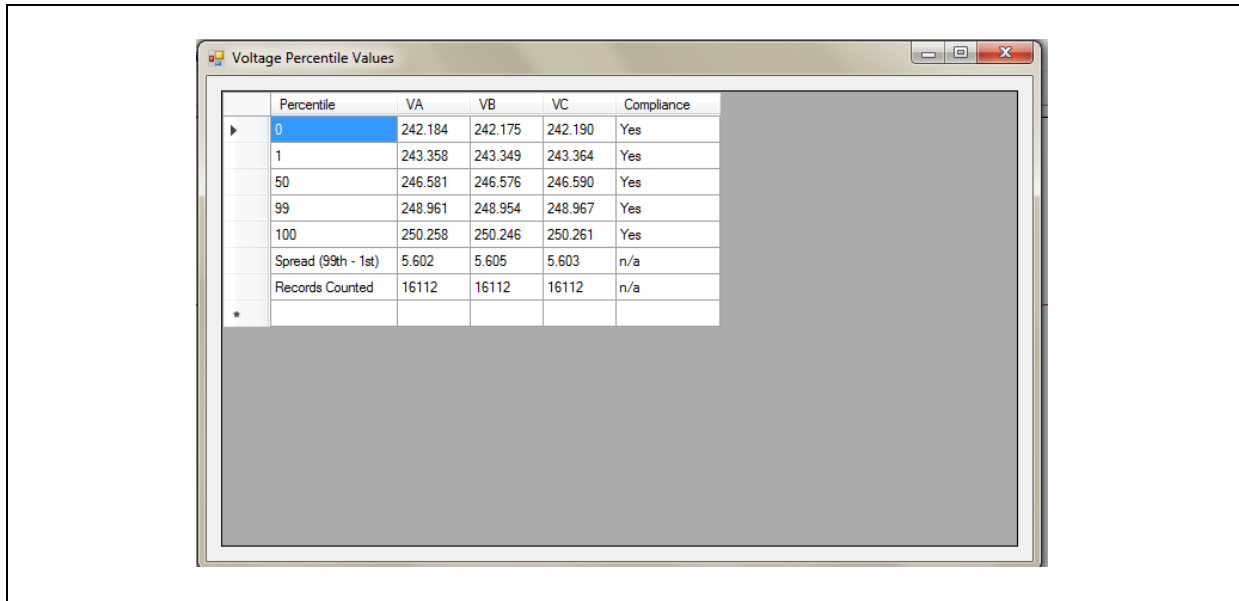

Figure 5.9.6.3.3

Figure 5.9.6.3.3 shows that all channel metrics are in compliance. The corresponding histogram can be generated by clicking on 'Histogram' button and is shown in figure 5.9.6.3.4.

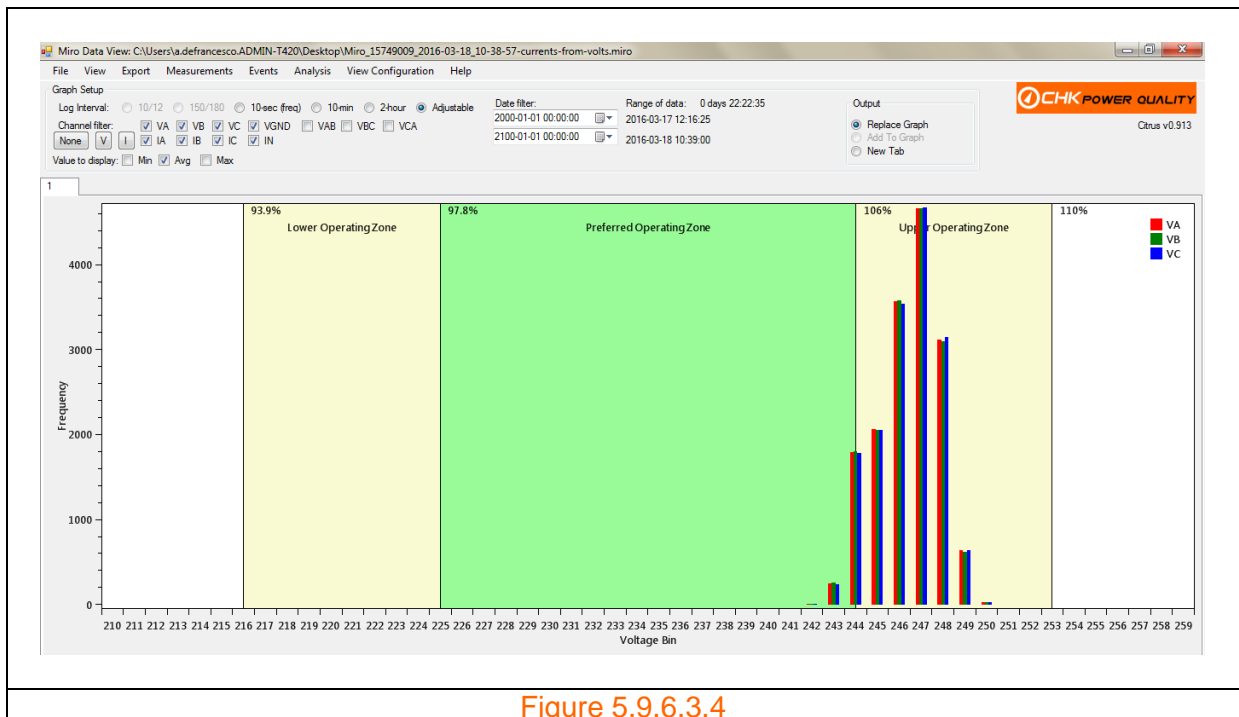

Figure 5.9.6.3.4

The user can restrict the voltage compliance analysis to any combination of VA, VB and VC by selecting the desired channels in 'Graph Setup' as shown in figure 5.9.6.3.5.

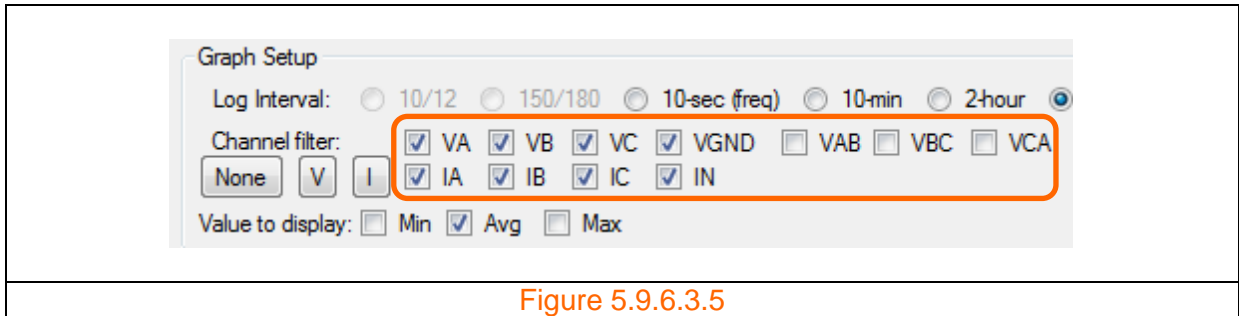

Figure 5.9.6.3.5

For example, as shown in figure 5.9.6.3.6, if only channel A is selected then the percentile table will only show VA and indicate the corresponding compliance status.

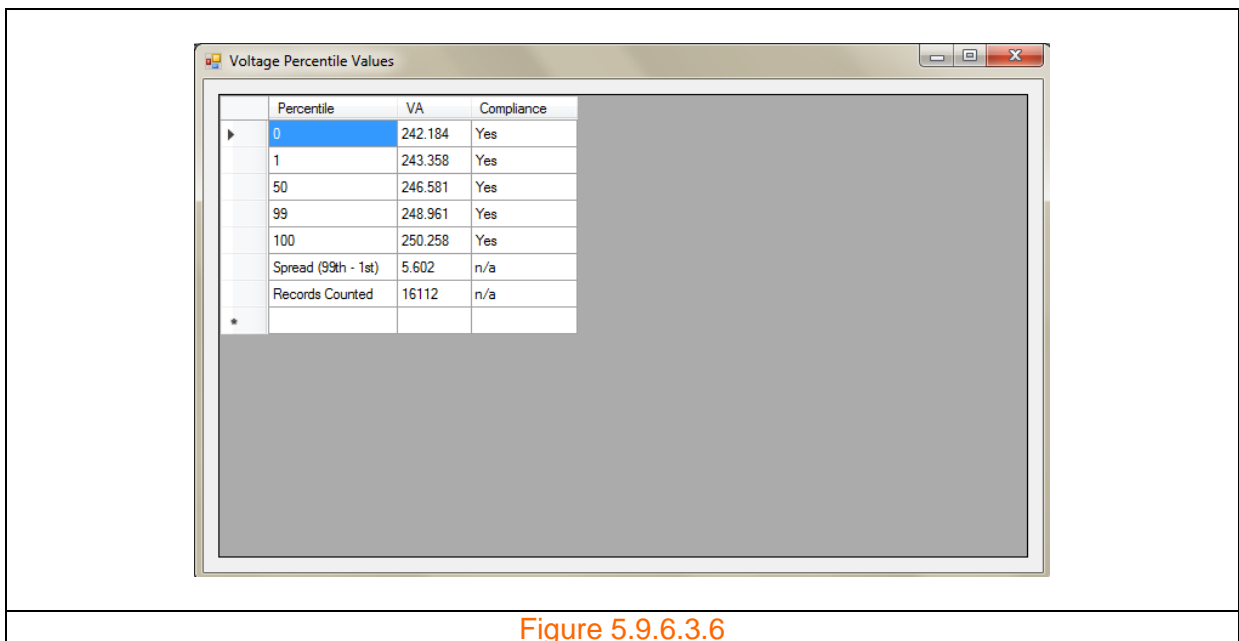

Figure 5.9.6.3.6

The corresponding histogram is shown in figure 5.9.6.3.7.

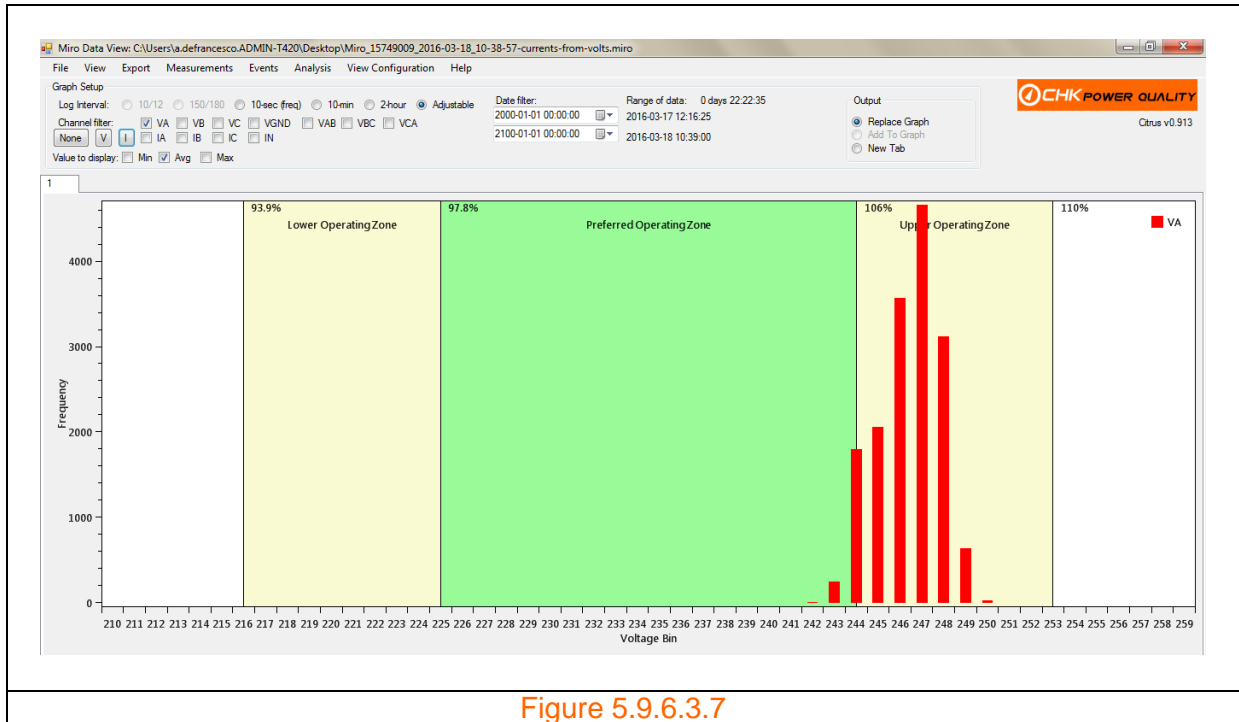

Figure 5.9.6.3.7

The voltage compliance analysis normally discards flagged measurements which are only triggered by dips, swells, and interruptions.

The 'Setup' form allows the user to 'Include Flagged Values'. Figures 5.9.6.3.8 and 5.9.6.3.9 shows histograms with and without flagged values.

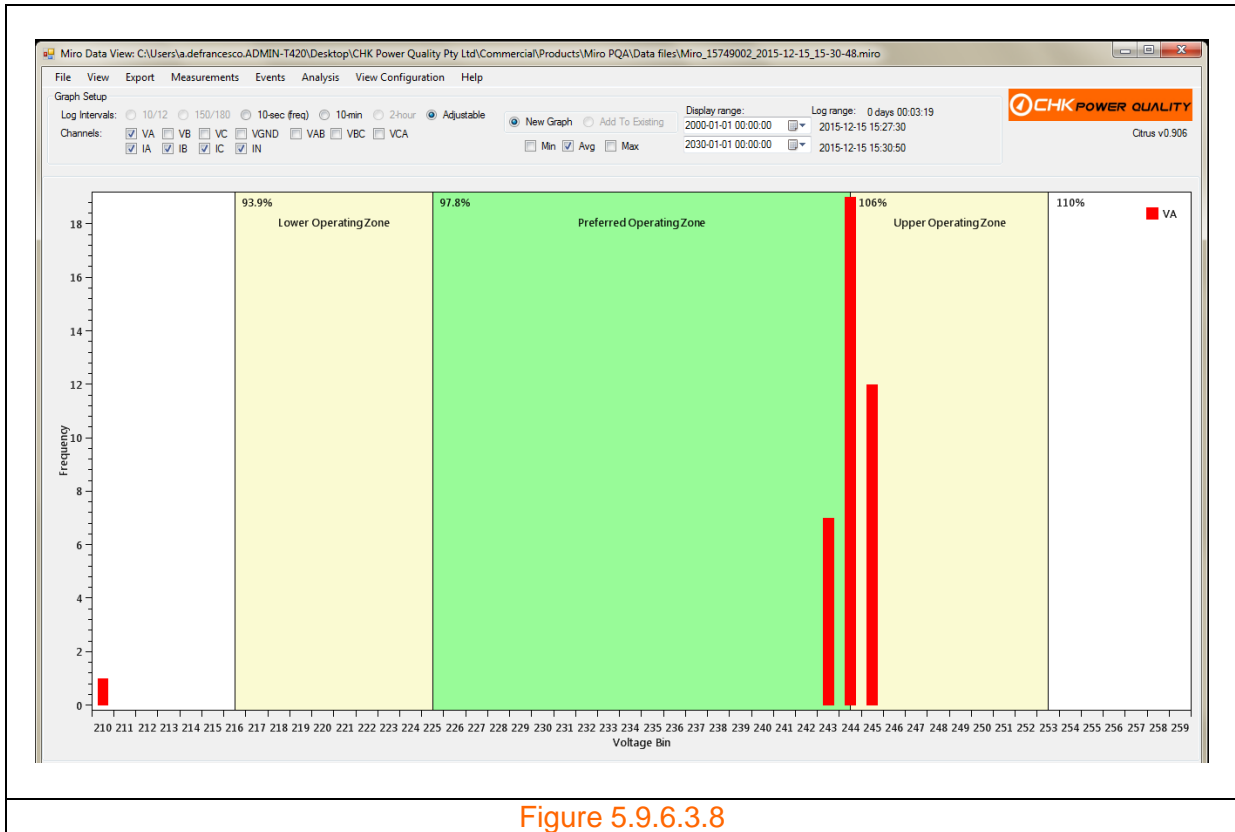

Figure 5.9.6.3.8

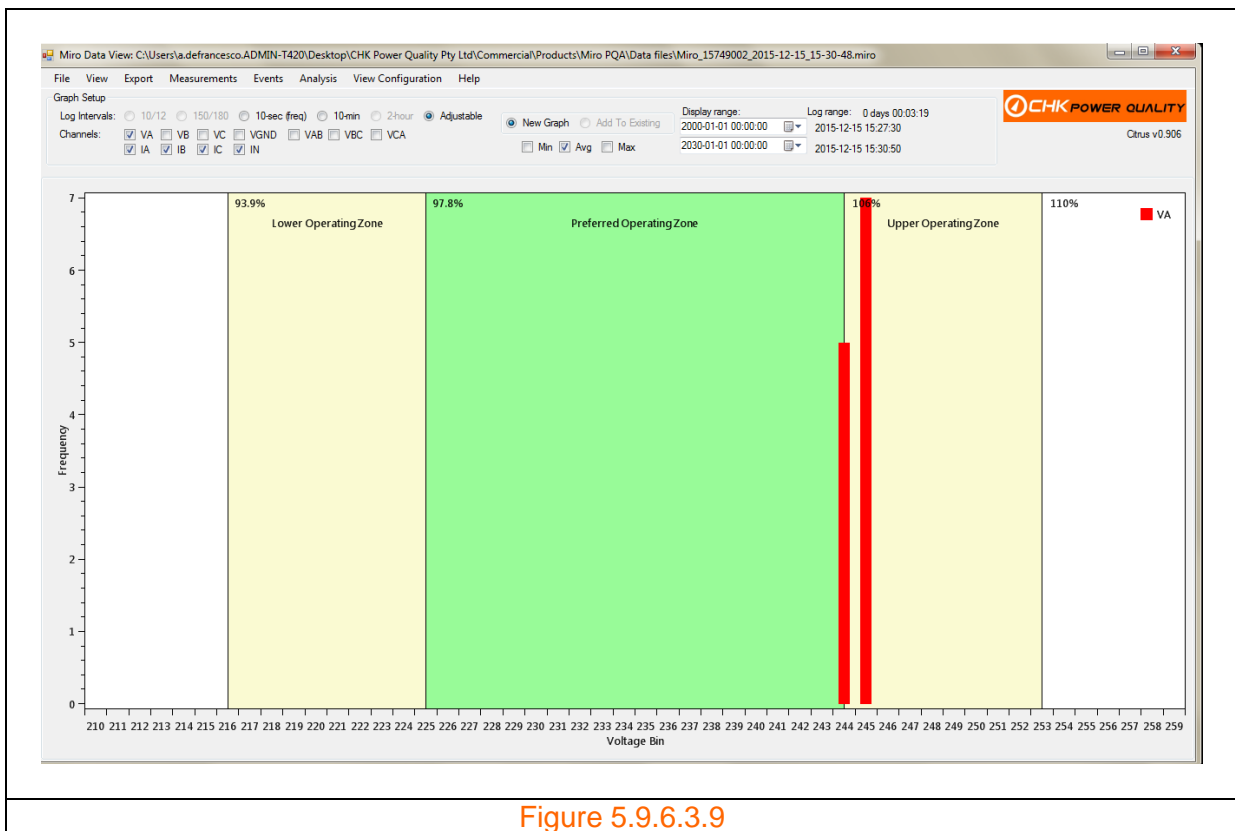
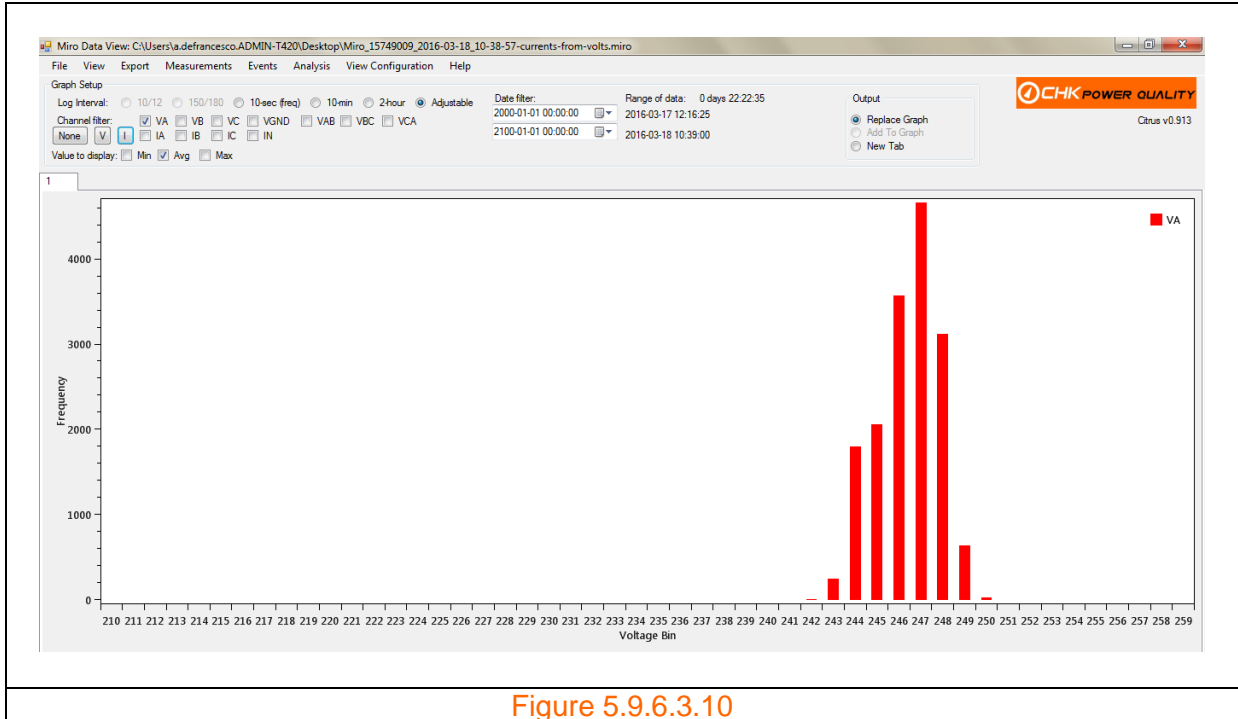

Figure 5.9.6.3.9

The histogram can be graphed without the compliance limits by unchecking 'Enable Compliance Limits' checkbox. The corresponding histogram is shown in figure 5.9.6.3.10.



5.9.6.4 Energy

Clicking on the 'Energy' button opens another submenu providing options to select either 'kWh', 'kvarh', 'kVAh', 'kWh hourly profile' or 'kWh hourly import/export' as shown in figure 5.9.6.4.1.

Click on the 'kWh' button and a table appears as shown in figure 5.9.6.4.2 displaying the total energy in kWh for each phase and includes the 'Net', 'Import (+ve)' and 'Export (-ve)' energies.

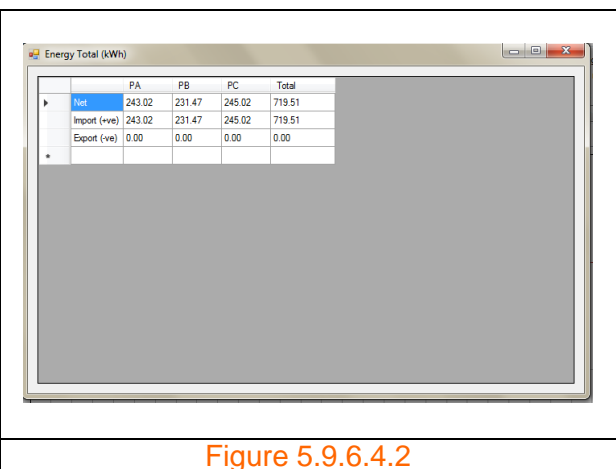
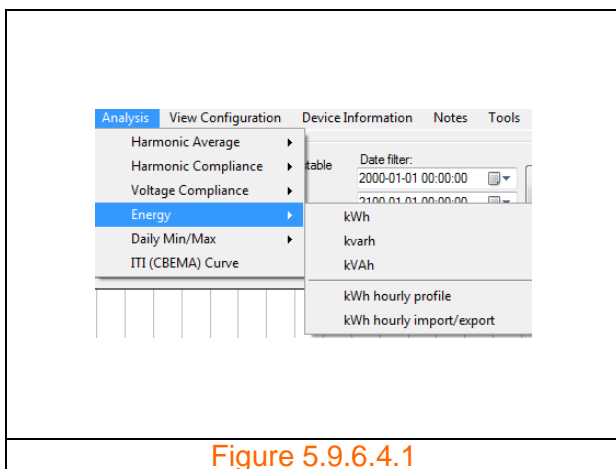

Click on the 'kvarh' band 'kVAh' buttons and tables appear as shown in figures 5.9.6.4.3 and 5.9.6.4.4 displaying the 'Net' energy in kvarh and kVAh for each phase.

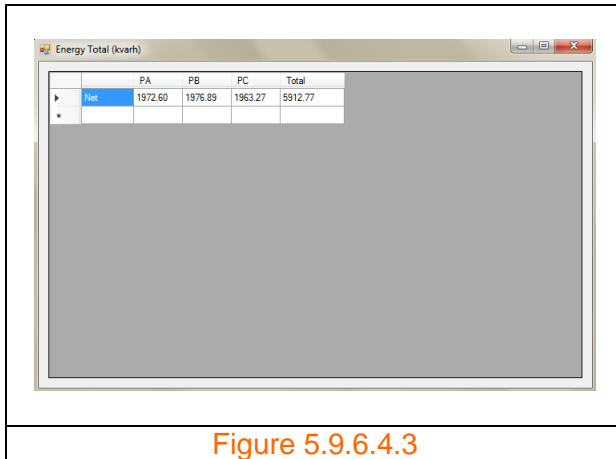

Figure 5.9.6.4.3

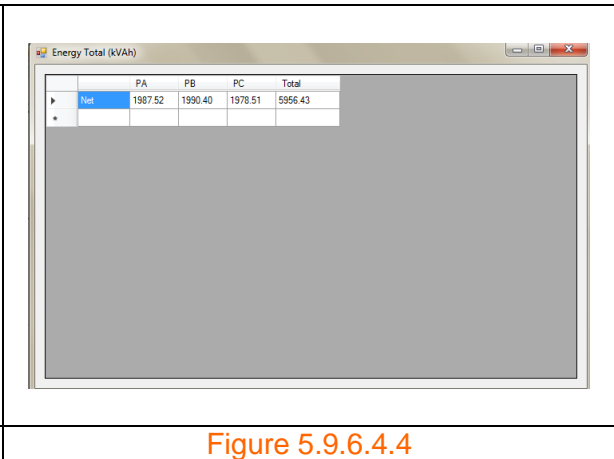

Figure 5.9.6.4.4

Click on 'kWh hourly profile' or 'kWh hourly import/export' buttons and graphs shown in figures 5.9.6.4.5 and 5.9.6.4.6 appear.

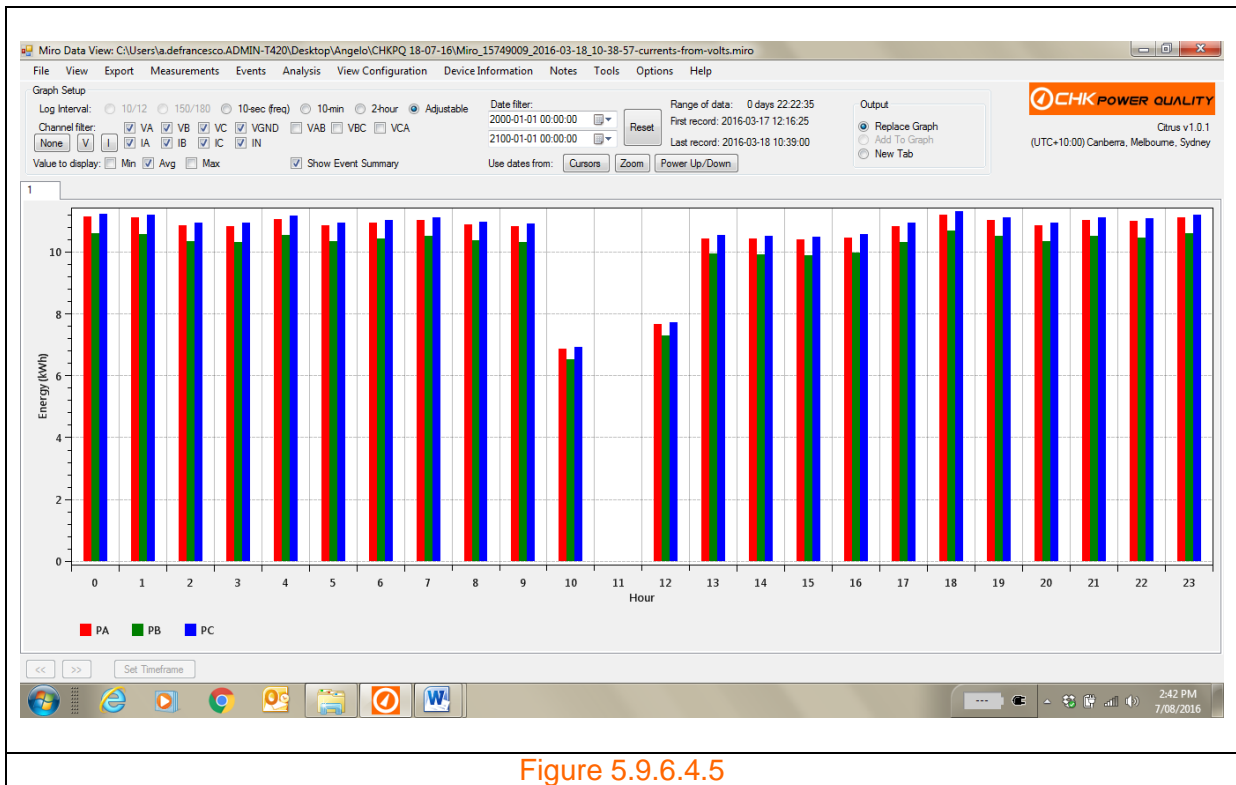
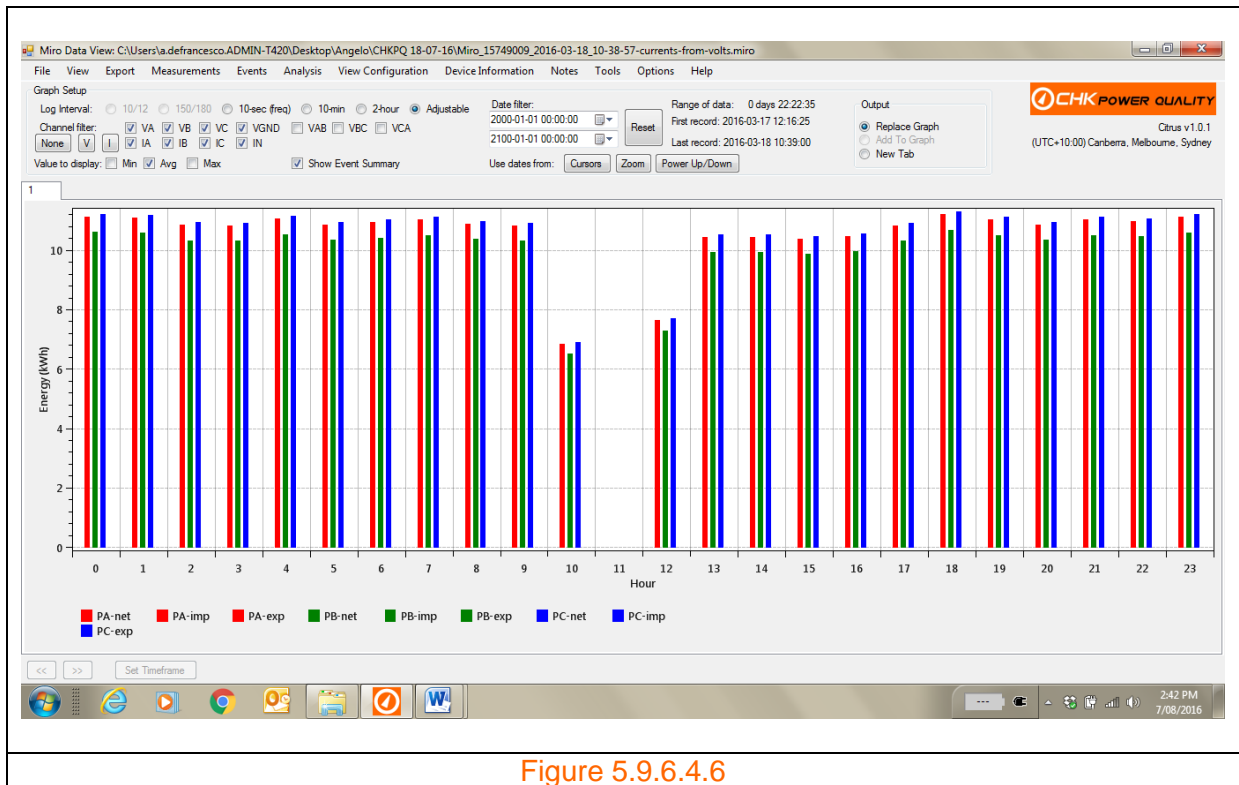
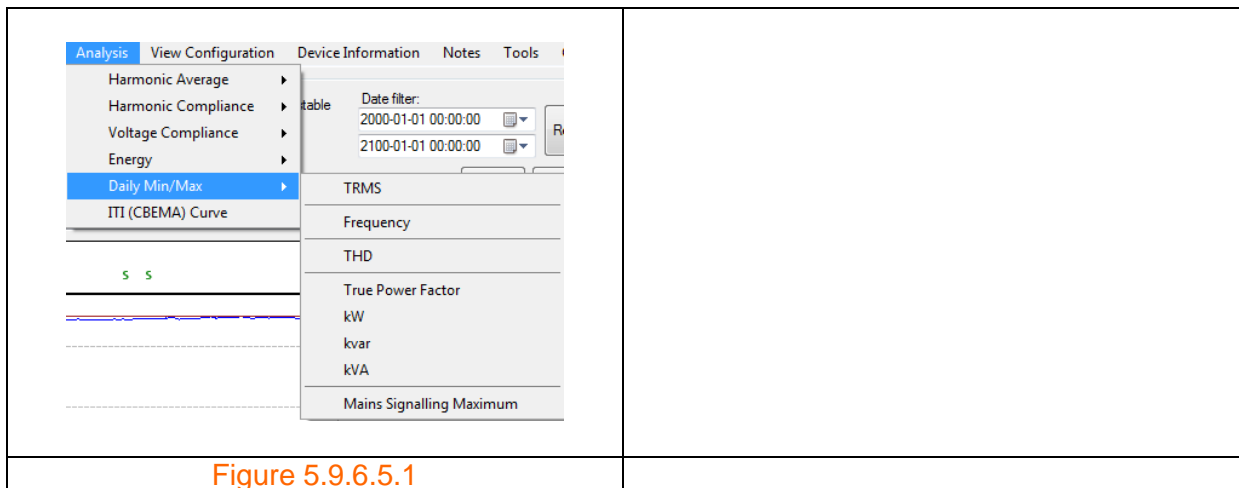

Figure 5.9.6.4.5



5.9.6.5 Daily min / max

Clicking on the 'Daily Min/Max' button opens a submenu providing options to select either 'TRMS', 'Frequency', 'THD', 'True Power Factor', 'kW', 'kvar', 'kVA' or 'Mains Signalling Maximum' as shown in figure 5.9.6.5.1.



Clicking any of the submenu buttons listed above generates a table which displays the daily minimum and maximum of the relevant metric for each channel and also the total minimum and maximum of the metric during the log period. Figure 5.9.6.5.2 shows the table format.

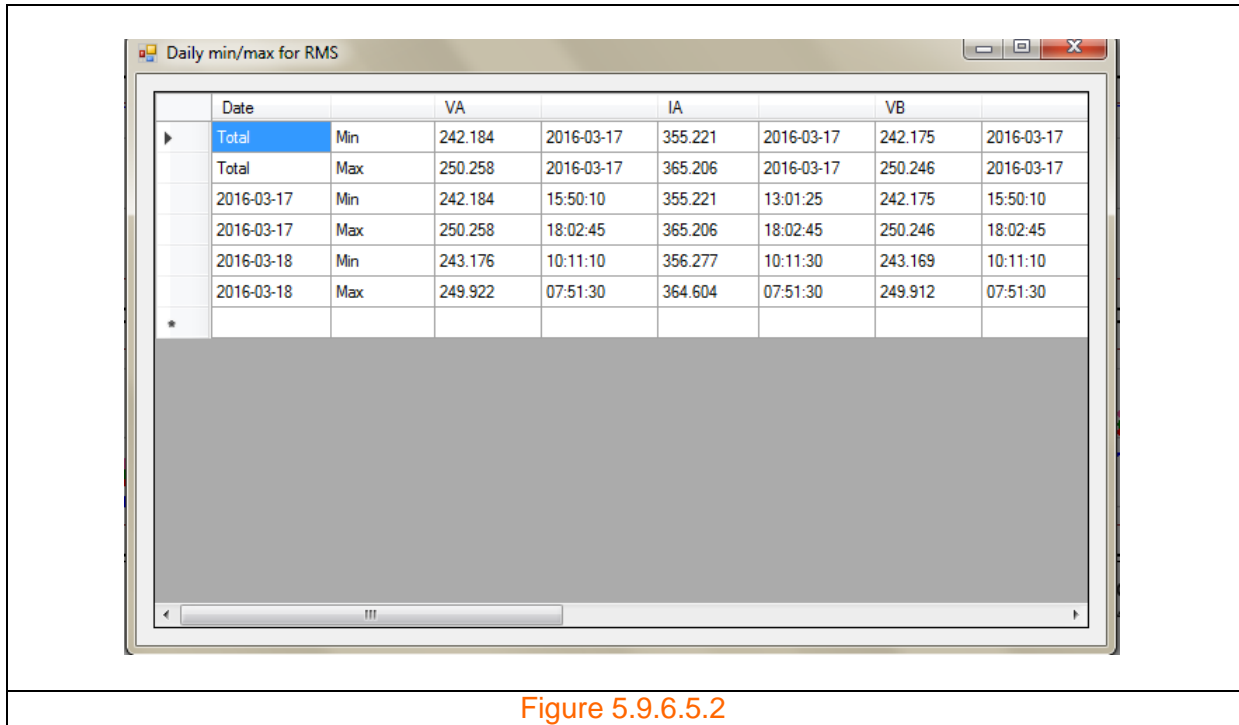

Figure 5.9.6.5.2

5.9.6.6 ITI (CBEMA) curve

Clicking on the 'ITI (CBEMA) Curve' button shown in figure 5.9.6.6.1 generates a graph as shown in figure 5.9.6.6.2. The graph plots dips and swells. In this case nothing is plotted as no dips or swells are recorded. Figure 5.9.6.6.3 shows a graph with dip and swell events.

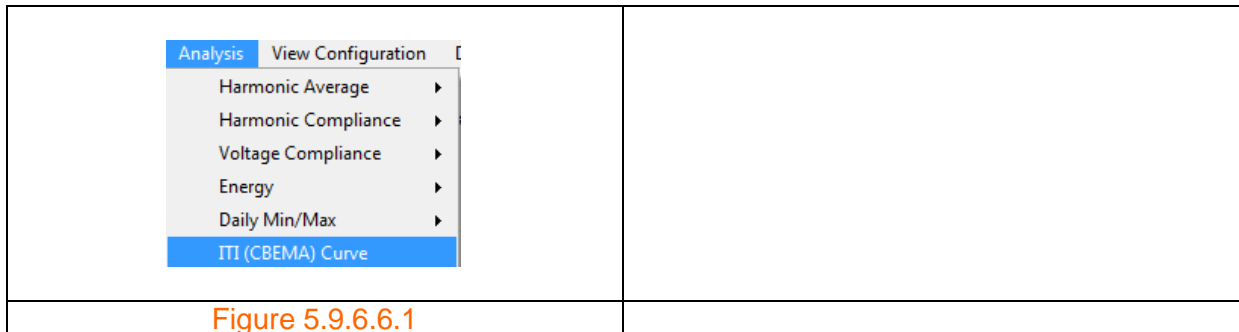
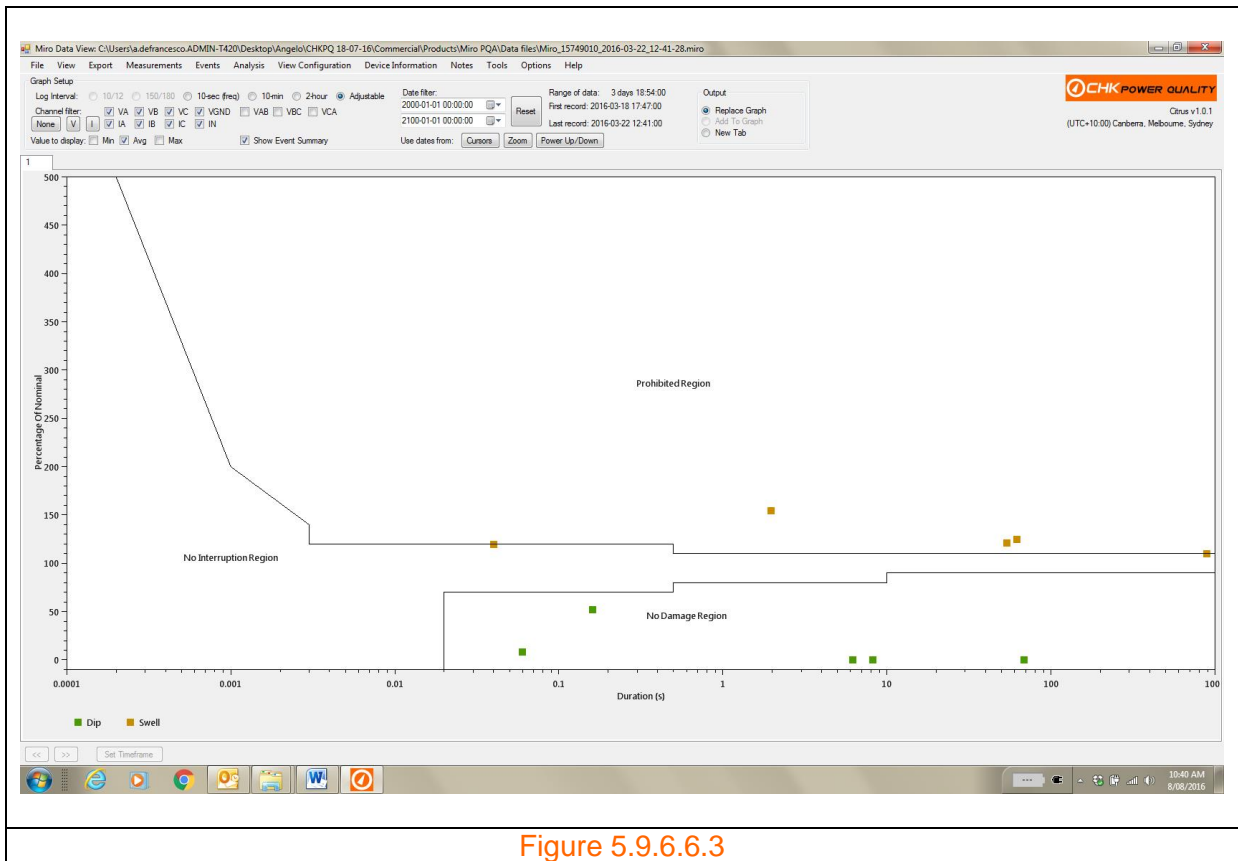
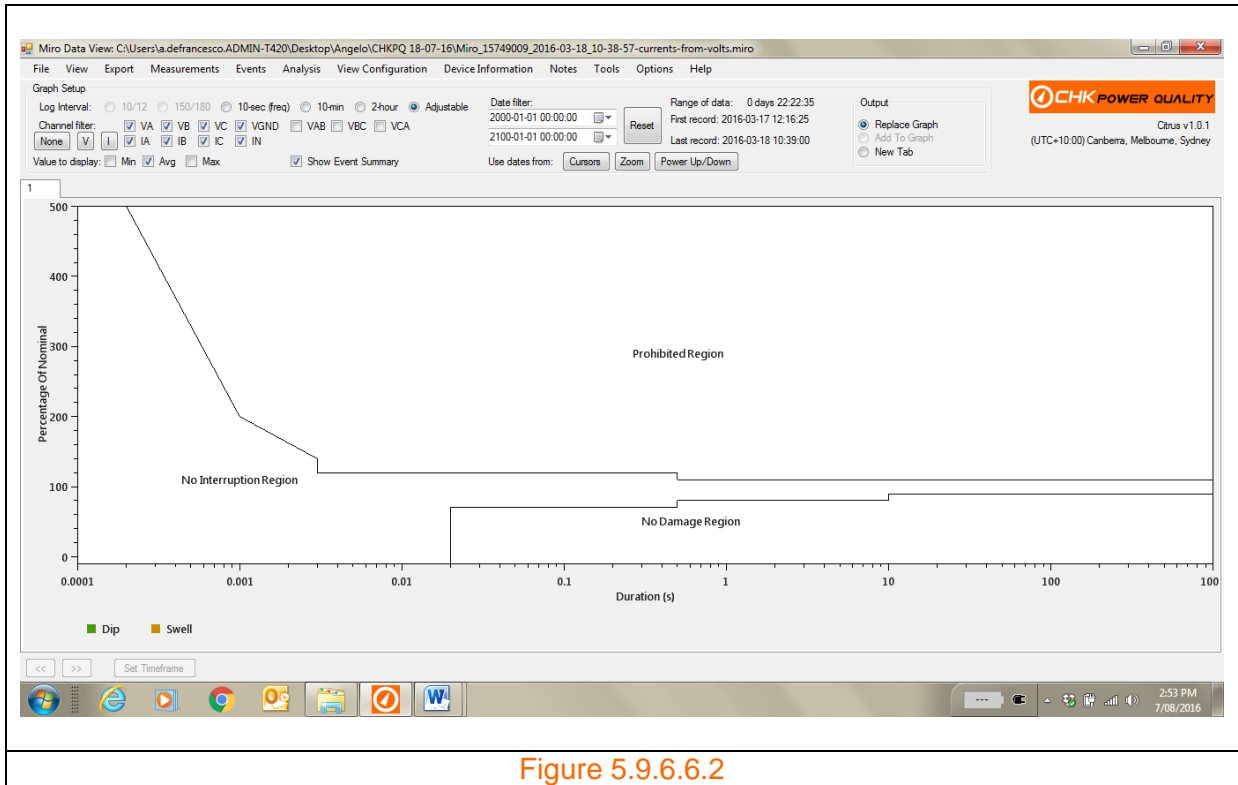
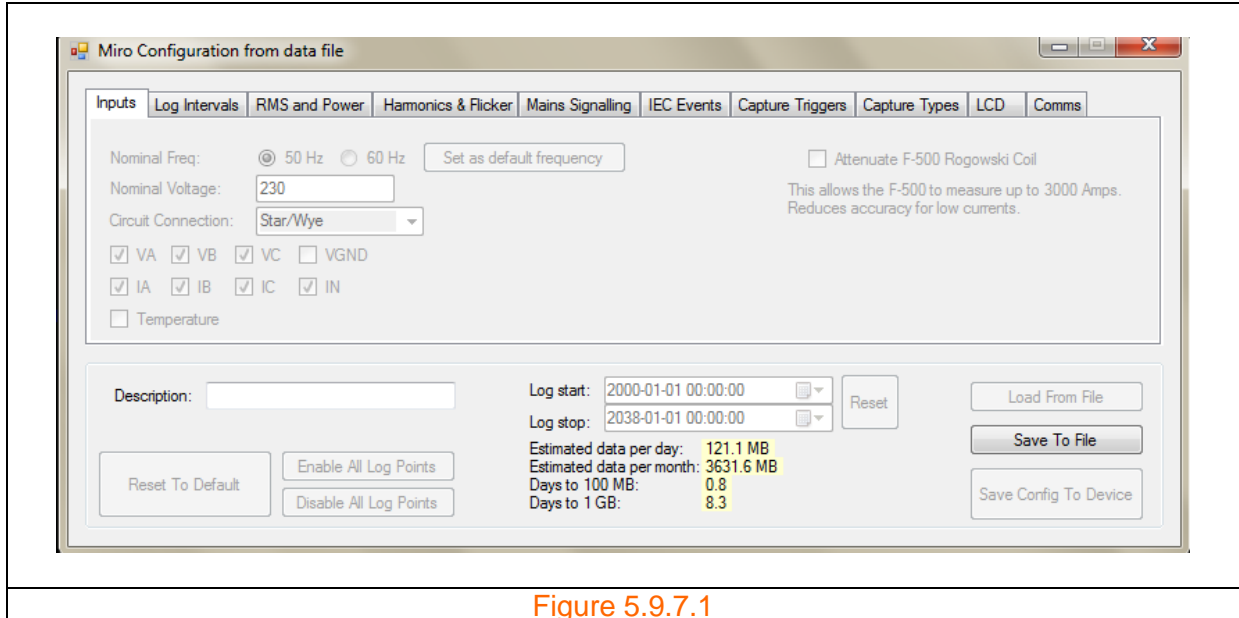

Figure 5.9.6.6.1



5.9.7 View Configuration

Clicking on the 'View Configuration' menu button provides the user with the configuration attached to the data file as shown in figure 5.9.7.1. The user is unable to change the configuration from this view.



5.9.7.1 Multiple configurations

If the user has more than one data file opened then when clicking on the 'View Configuration' menu button a selection form appears as shown in figure 5.9.7.1.1 which allows the user to choose the desired configuration.

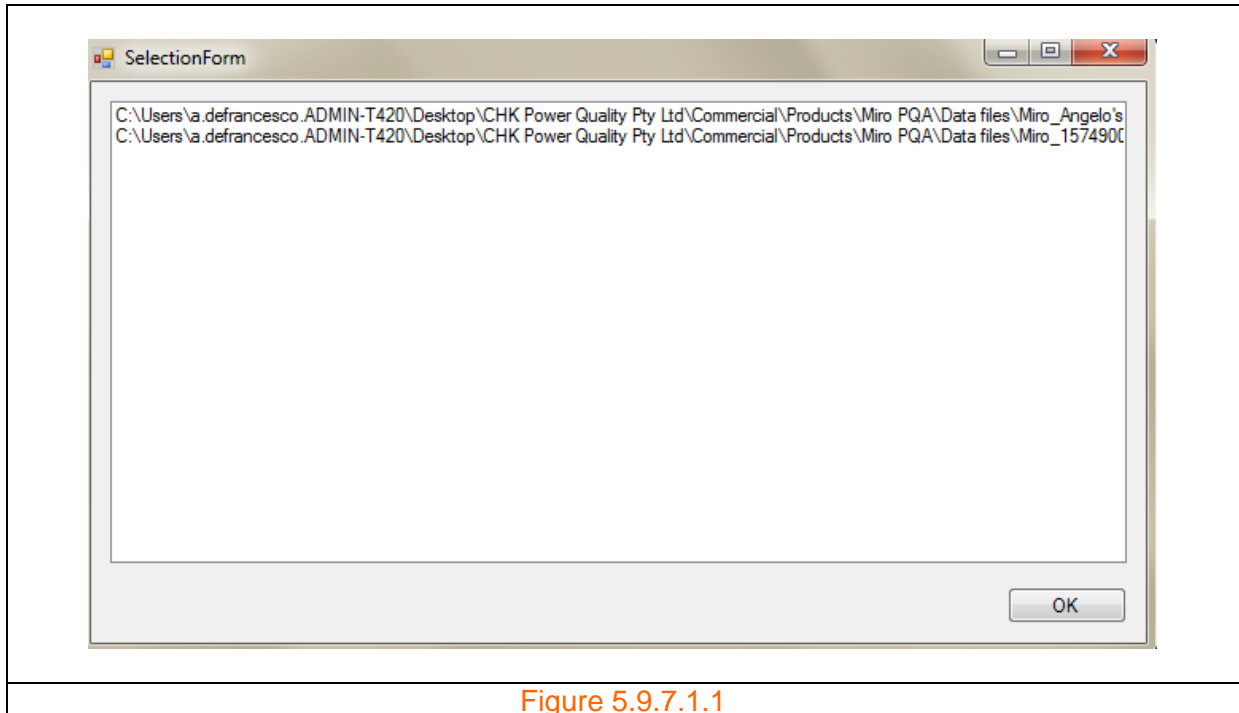

Figure 5.9.7.1.1

5.9.8 Device information

Clicking on the 'Device Information' menu button provides the user with Miro specific information as shown in figure 5.9.8.1.

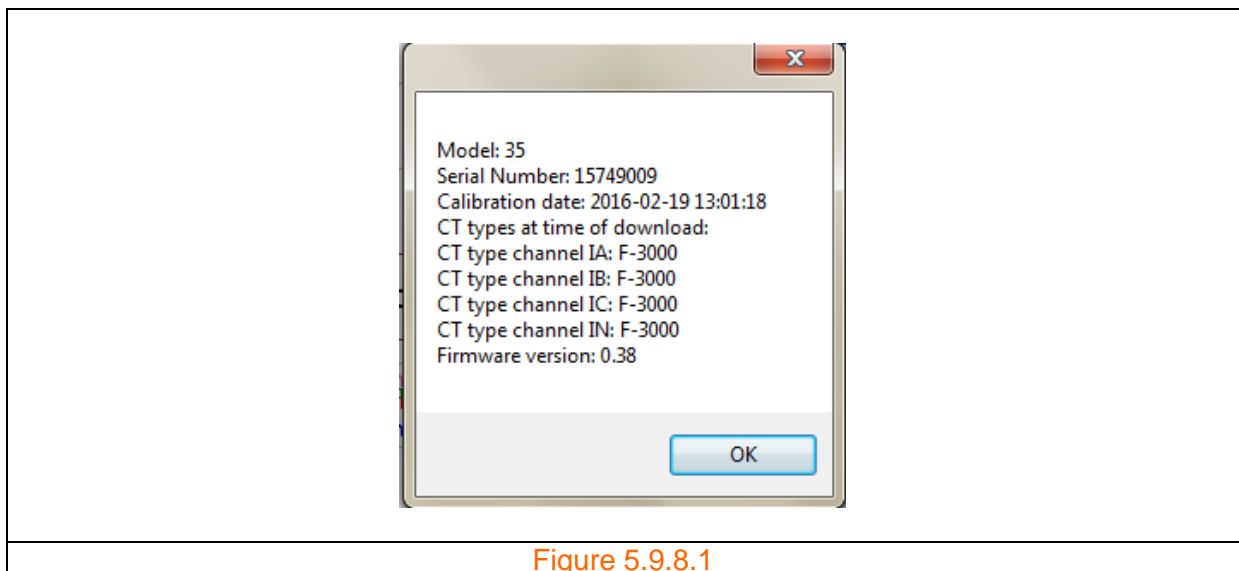
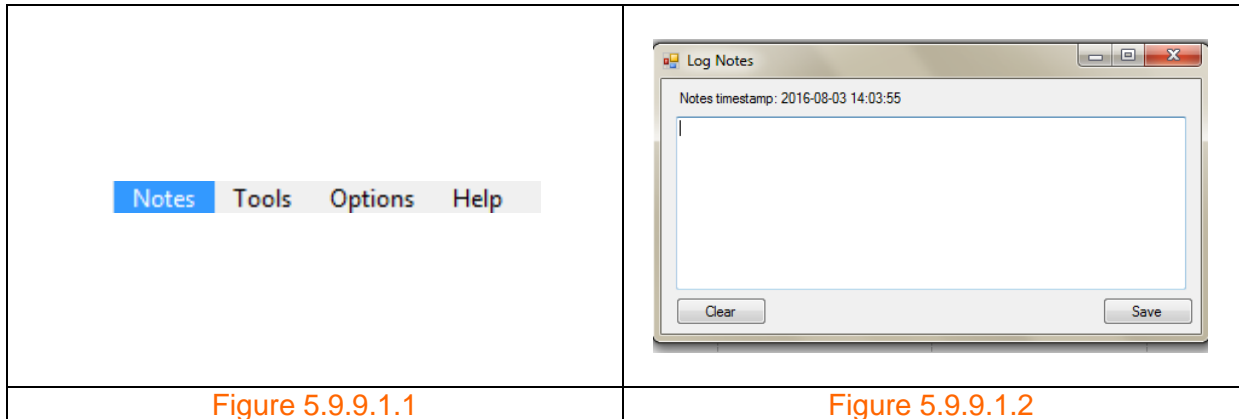

Figure 5.9.8.1

5.9.9 Notes

Step 1: Click the 'Notes' menu shown in figure 5.9.9.1.1 An input box appears as shown in figure 5.9.9.1.2 allowing the user to type in text.



Step 2: Type in desired text. Figure 5.9.9.1.3 shows example text. Click 'Save'.

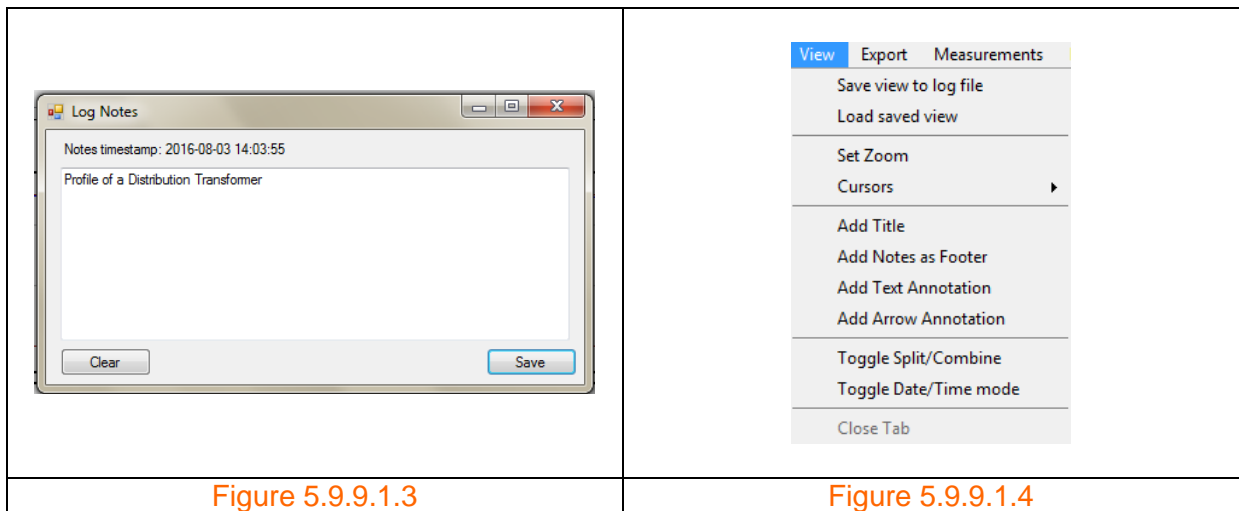

Step 3: Click the 'View' menu as shown in figure 5.9.9.1.4 and then on 'Add Notes as Footer'. The text is now appended to the graph as shown in figure 5.9.9.1.5. Clicking the 'Add Notes as Footer' item again will remove the text from the graph.

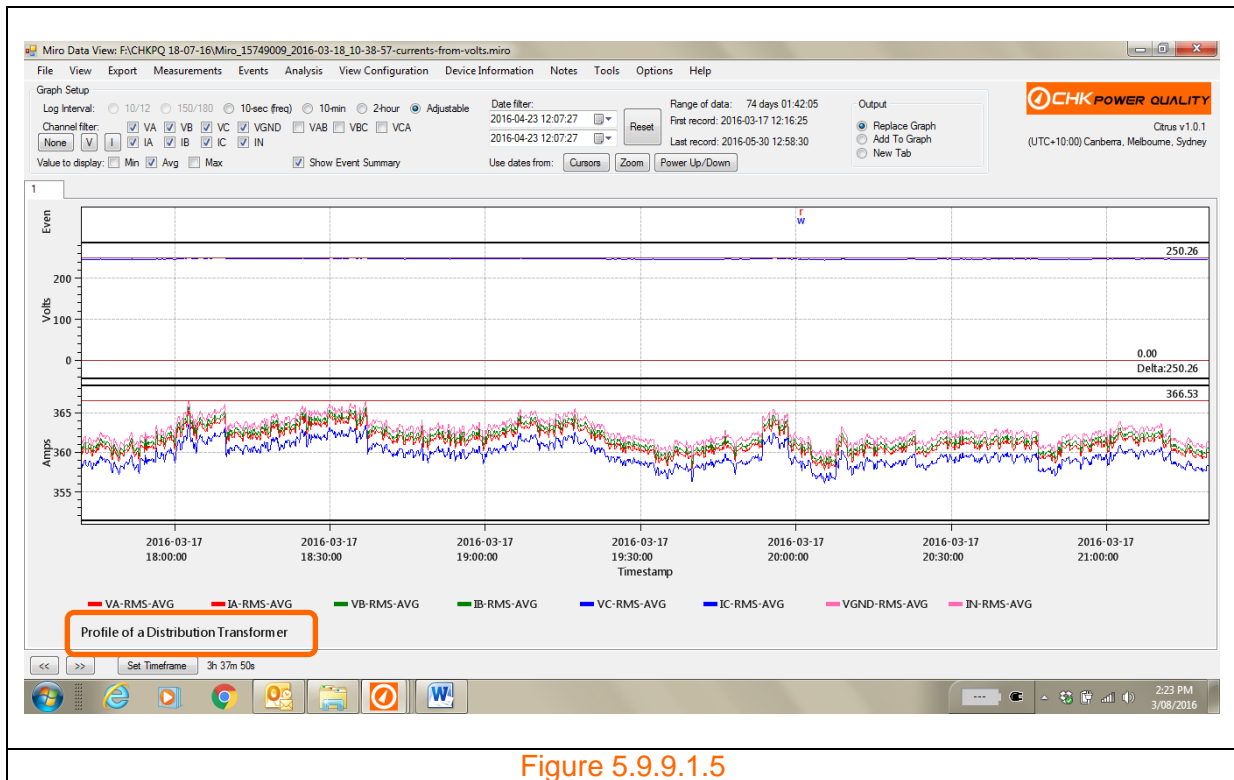

Figure 5.9.9.1.5

5.9.10 Tools

5.9.10.1 Merge open files

Note: This feature requires that at least two files are added to the active window.

Step 1: Click the 'Tools' menu shown in figure 5.9.10.1.1. A drop down box appears as shown in figure 5.9.10.1.2.

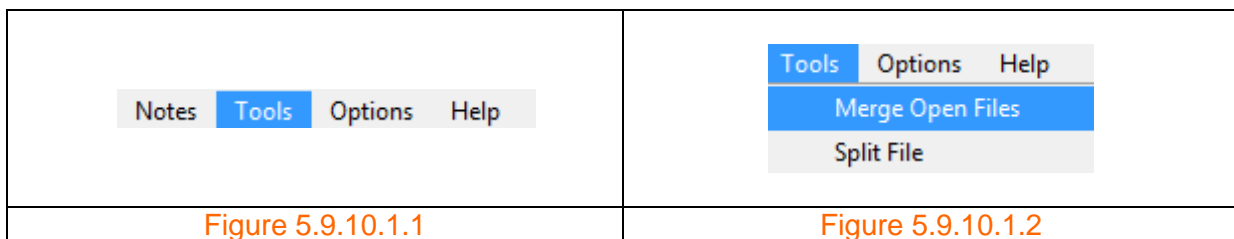

Step 2: Hover and click on 'Merge Open Files'. A window appears as shown in figure 5.9.10.1.3 allowing the user to save the merged file. Click on 'Save'.

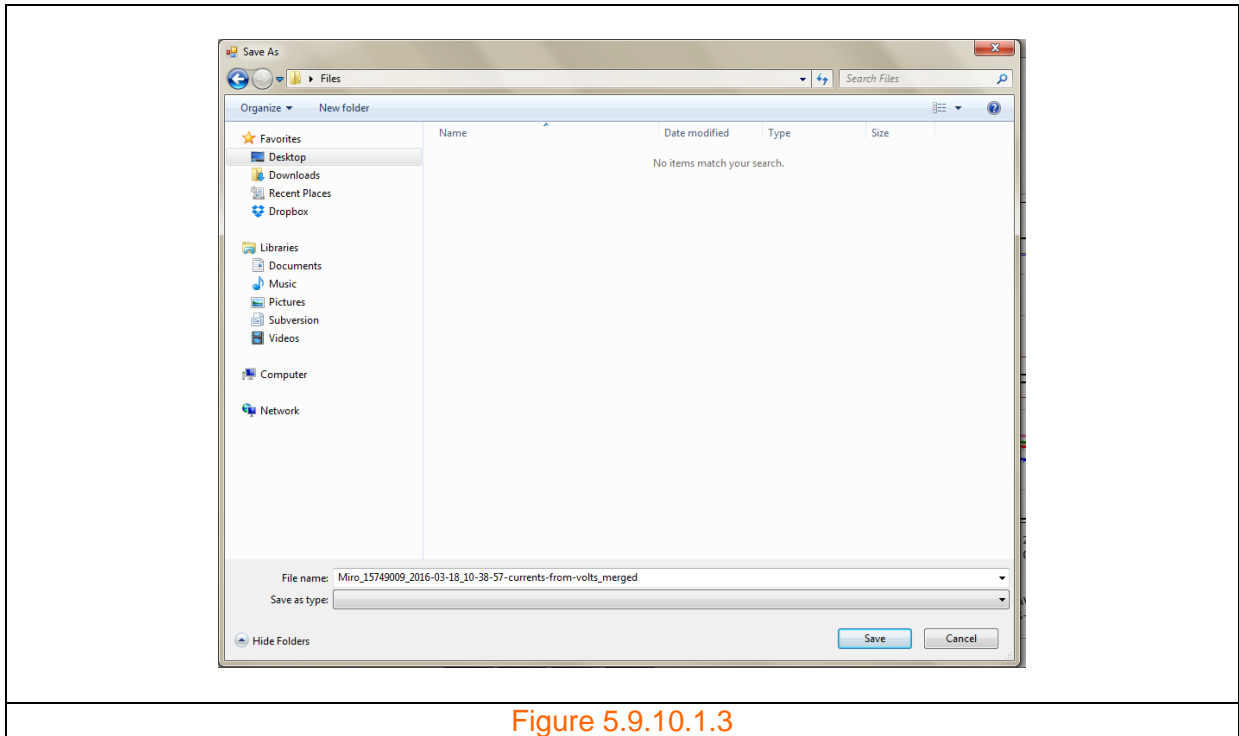

Figure 5.9.10.1.3

A message box appears as shown in figure 5.9.10.1.4 confirming the file merge.

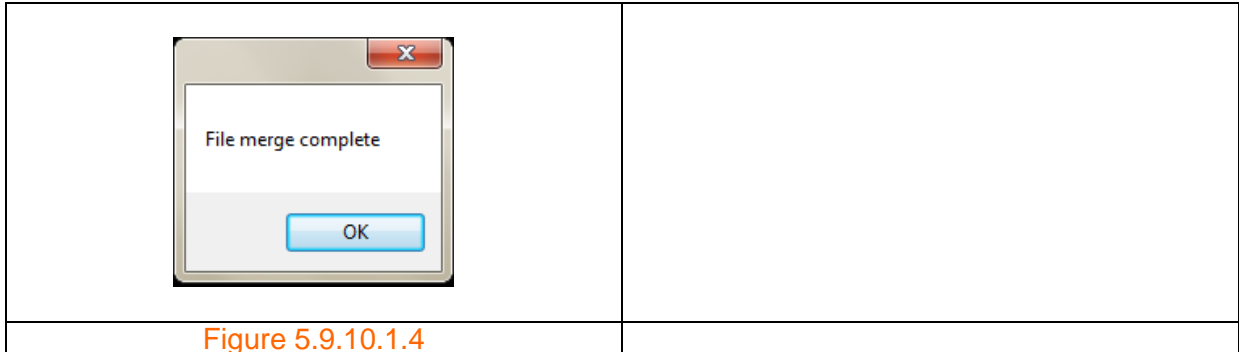

Figure 5.9.10.1.4

5.9.10.2 Split file

Note: This feature requires that a date range be set.

Step 1: Click the 'Tools' menu shown in figure 5.9.10.2.1. A drop down box appears as shown in figure 5.9.10.2.2.

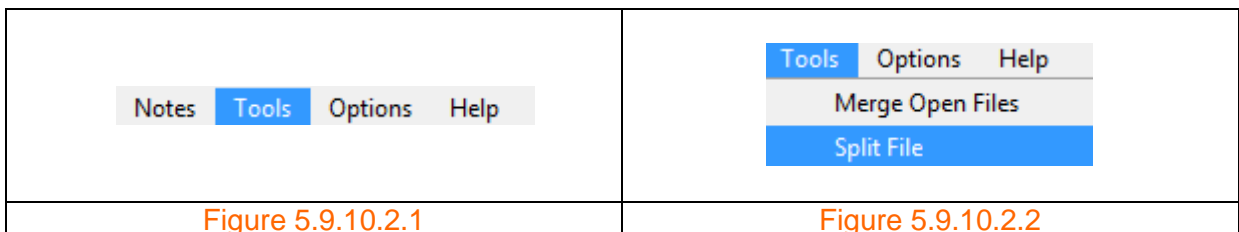
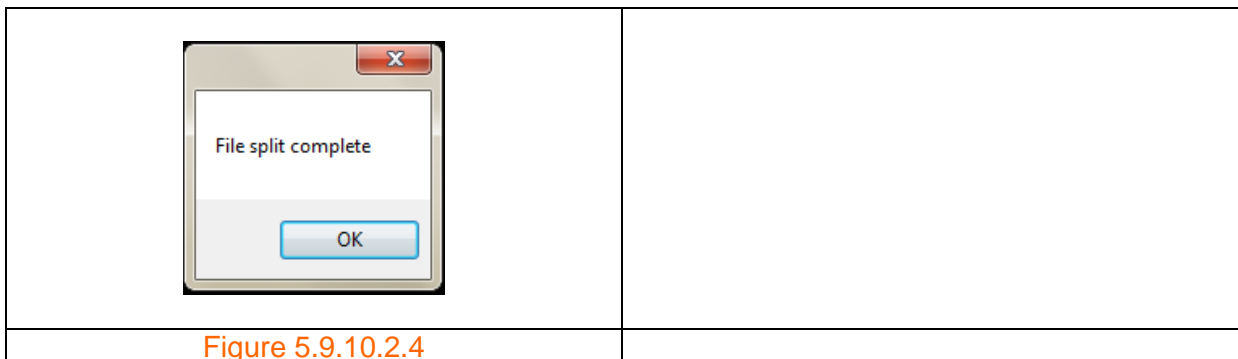
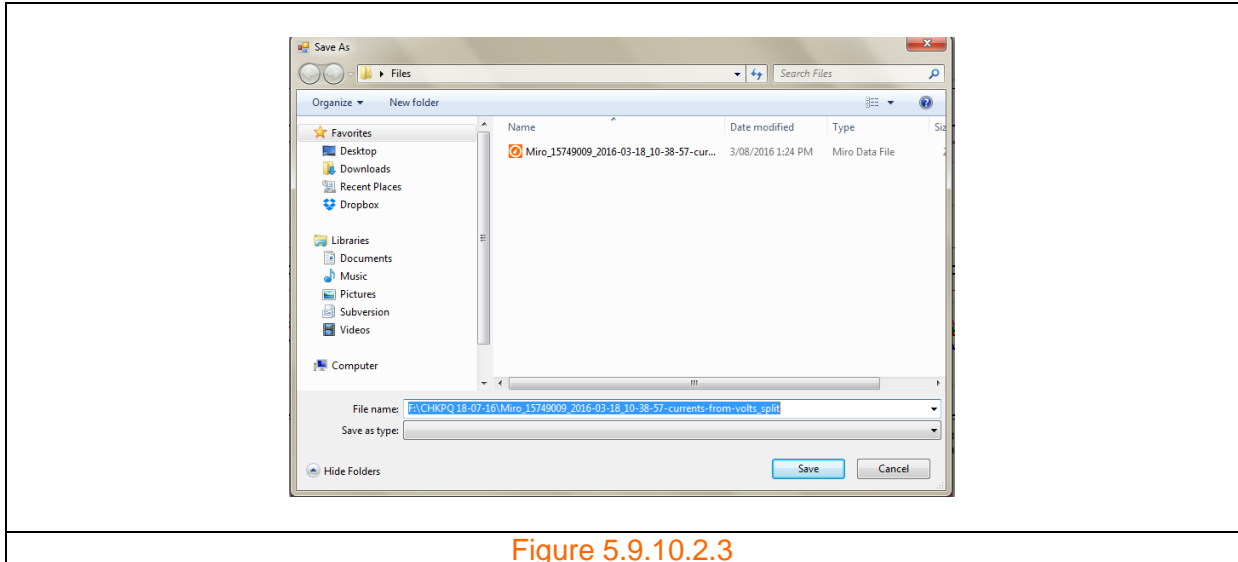

Figure 5.9.10.2.1

Figure 5.9.10.2.2

Step 2: Hover and click on 'Split File'. A window appears as shown in figure 5.9.10.2.3 allowing the user to save the split file. Click on 'Save'. A message box appears as shown in figure 5.9.10.2.4 confirming the file split.



If a date range is not selected then a message box appears as shown in figure 5.9.10.2.5.

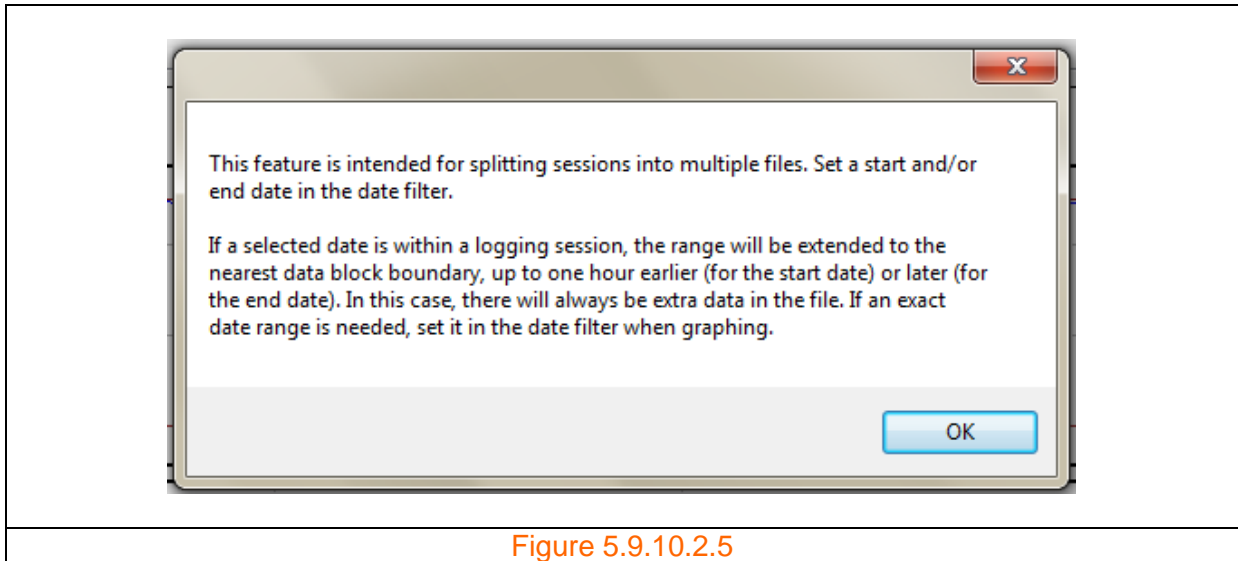

Figure 5.9.10.2.5

5.9.11 Options

5.9.11.1 Time zones

Miro data is logged in UTC time. The user is able to select a time zone for displaying data.

Step 1: Click the 'Options' menu shown in figure 5.9.11.1.1 A drop down box appears as shown in figure 5.9.11.1.2.

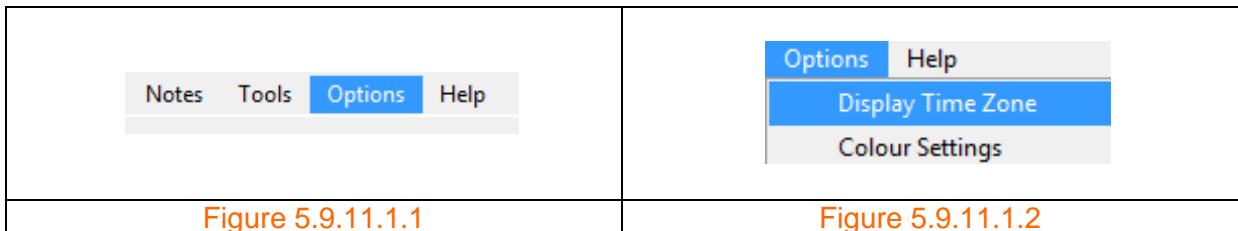

Step 2: Hover and click on 'Display Time Zone'. A form showing a list of time zones appears as shown in figure 5.9.11.1.3. The user can select a time zone from the list or use the PC time zone by clicking on the 'Use PC time zone' button.

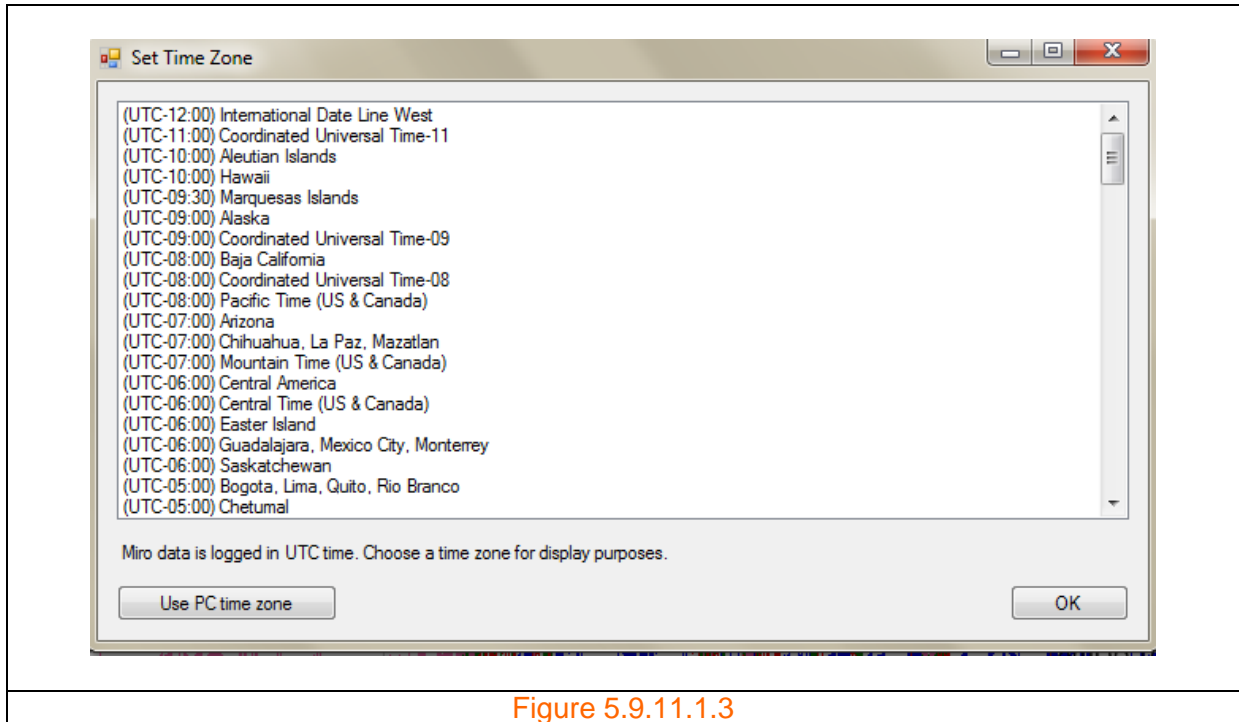
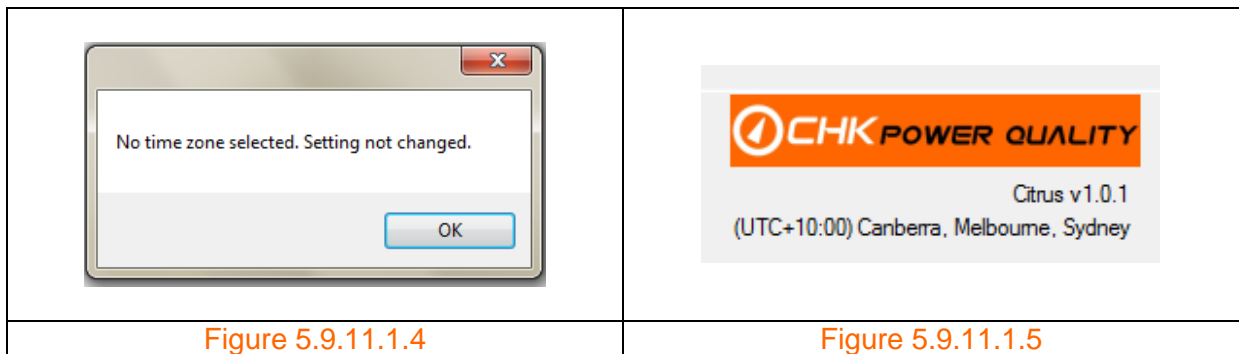

Figure 5.9.11.1.3

Step 3: Click the 'OK' button. If no time zone has been selected then a message box appears as shown in figure 5.9.11.1.4. The updated time zone appears just under the Citrus software version number as shown in figure 5.9.11.1.5.



5.9.11.2 Colour settings

The user is able to alter the colour settings.

Step 1: Click the 'Options' menu shown in figure 5.9.11.2.1 A drop down box appears as shown in figure 5.9.11.2.2.

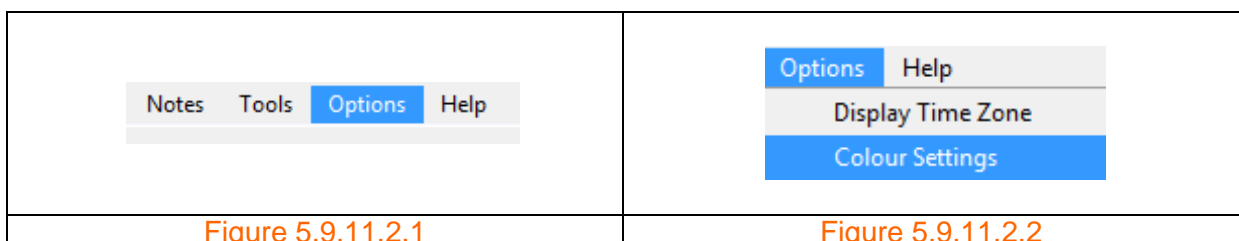

Step 2: Hover and click on 'Colour Settings'. A form showing the colour settings appears as shown in figure 5.9.11.2.3. The user can change the settings by moving the scroll bars or click on the 'Default Colours' button for factory settings.

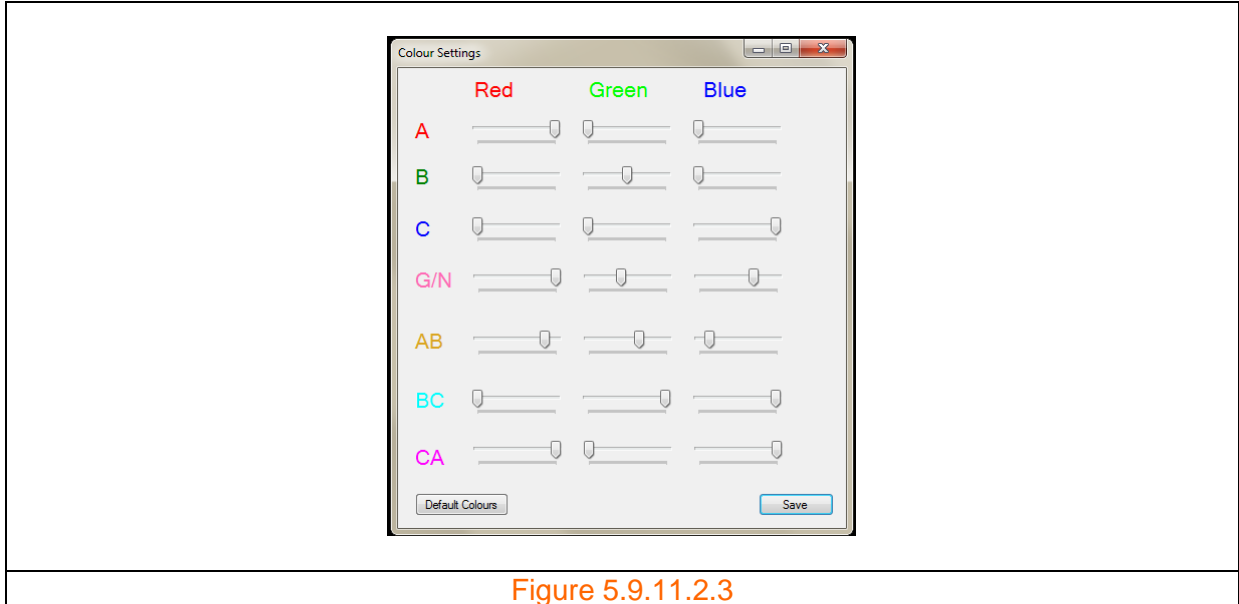

5.9.12 Help

Clicking on the 'Help' menu button provides the user with information on graphical features as shown in figure 5.9.12.1.

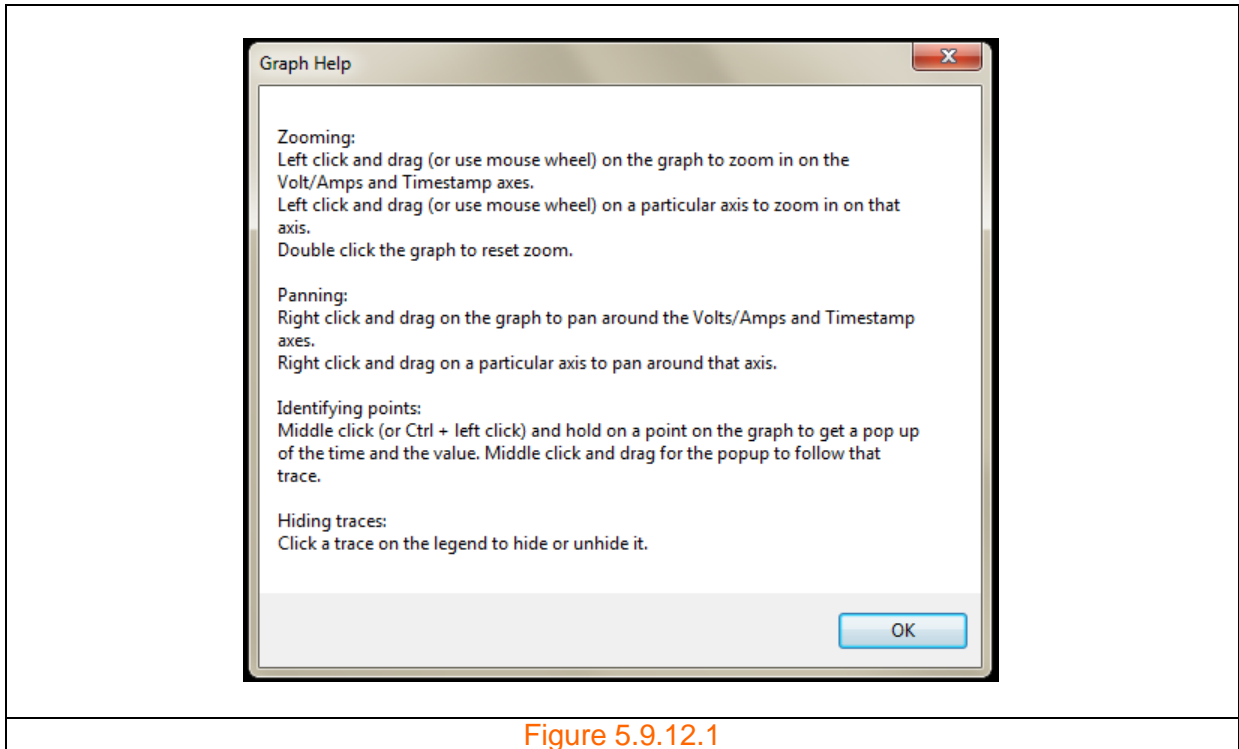

5.9.13 Graph setup

The 'Graph Setup' menu bar shown in figure 5.9.13.1 allows the user to view a restricted data set.

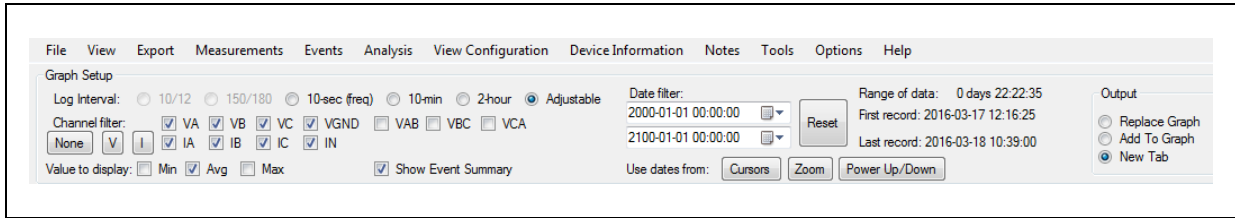

Figure 5.9.13.1

5.9.13.1 Log intervals

The user can display data at any of the six log intervals, provided it has been logged at the desired log intervals; if not then the log interval will be disabled. The example below in figure 5.9.13.1.1 shows that '10/12', '150/180' as disabled.

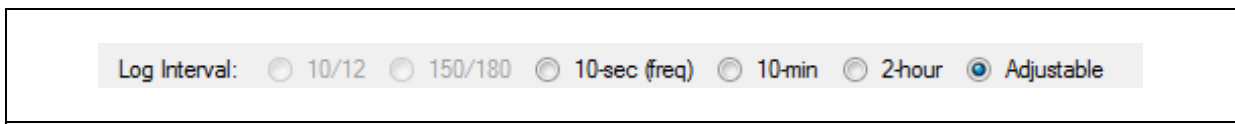

Figure 5.9.13.1.1

5.9.13.2 Channel filter

The user can view any combination of voltage and current channels as shown in figure 5.9.13.2.1.

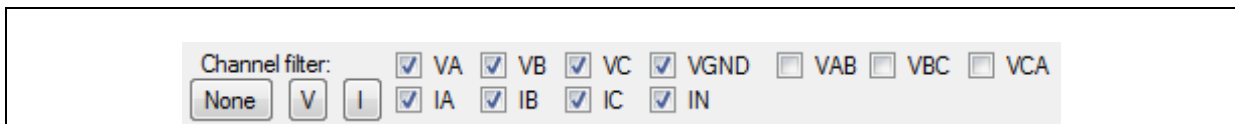

Figure 5.9.13.2.1

The user can quickly disable all channels by clicking the 'None' button. The user can quickly enable and disable all voltage and current channels by repeatedly clicking on the 'V' and 'I' buttons.

5.9.13.3 Display values

Graphs can display any values (minimum, average and maximum) shown in figure 5.9.9.3.1.

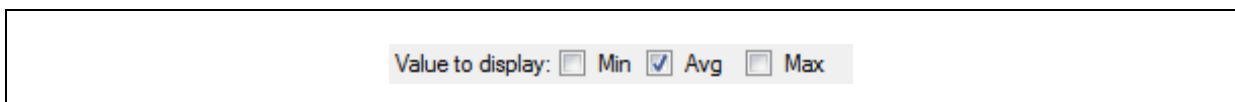

Figure 5.9.13.3.1

5.9.13.4 Date filter

As shown in figure 5.9.13.4.1 the user can use the date filter to select a data display range. The start date and time is at the top.

The actual data start and finish dates and times are displayed to the right of the date filter.

The data range is also displayed. In this case it is 22 hours, 22 minutes and 35 seconds.

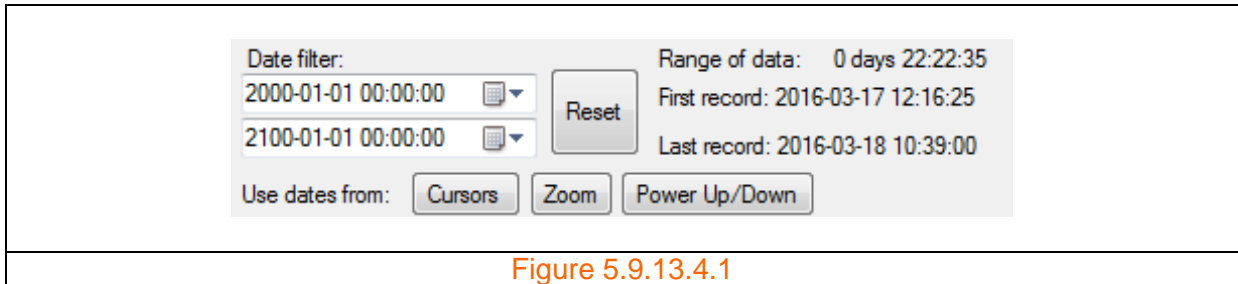

The date filter can be changed in various ways and include:

1. Directly;
2. Cursors;
3. Zoom;
4. Power up / down; and
5. Reset.

If the start and finish date-times are the same, example shown in figure 5.9.13.4.2, then attempting to analyse and or display data will result in the message box shown in figure 5.9.13.4.3.

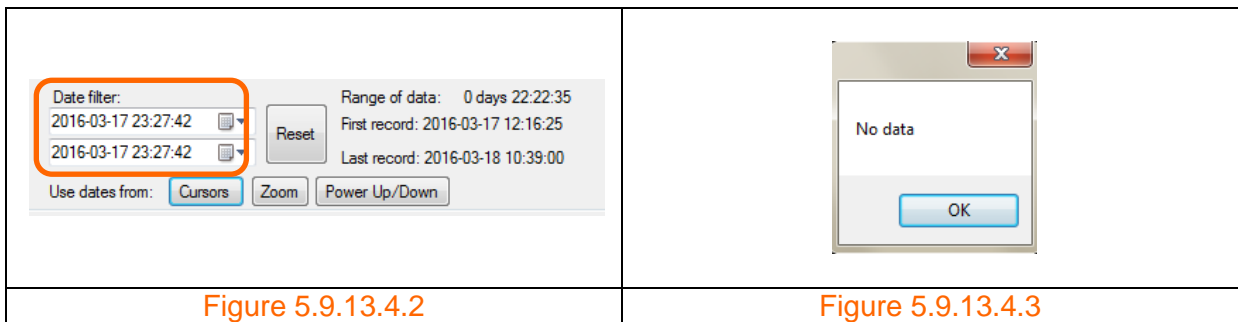

Directly

The user can type the desired start and finish dates and times into the date-time input boxes or use the calendar form as shown in figures 5.9.13.4.4 and 5.9.13.4.5.

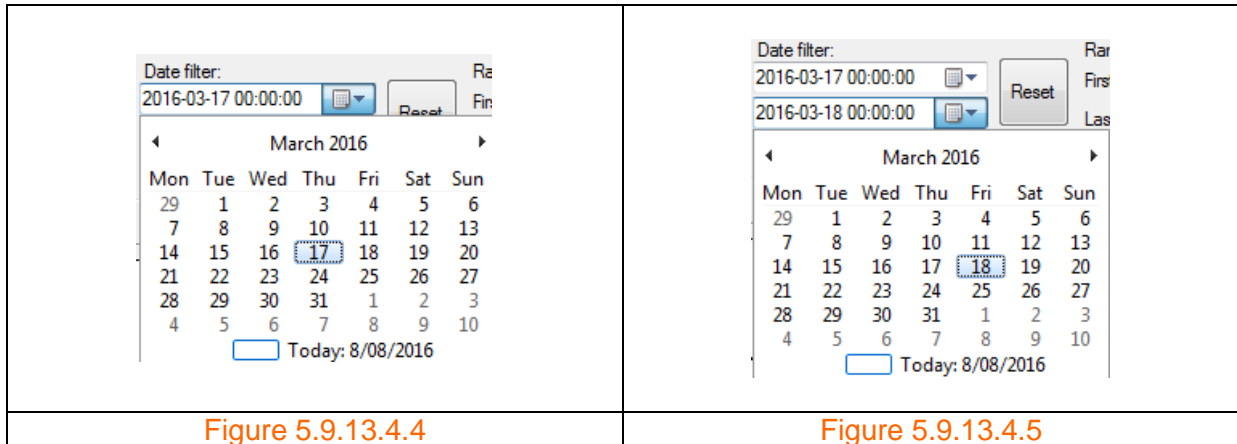

Cursors

The user can move the vertical cursors (time cursors) and then click on the 'Cursors' button. The start and finish date-times will now reflect the positions of the cursors as shown in figure 5.9.13.4.6.

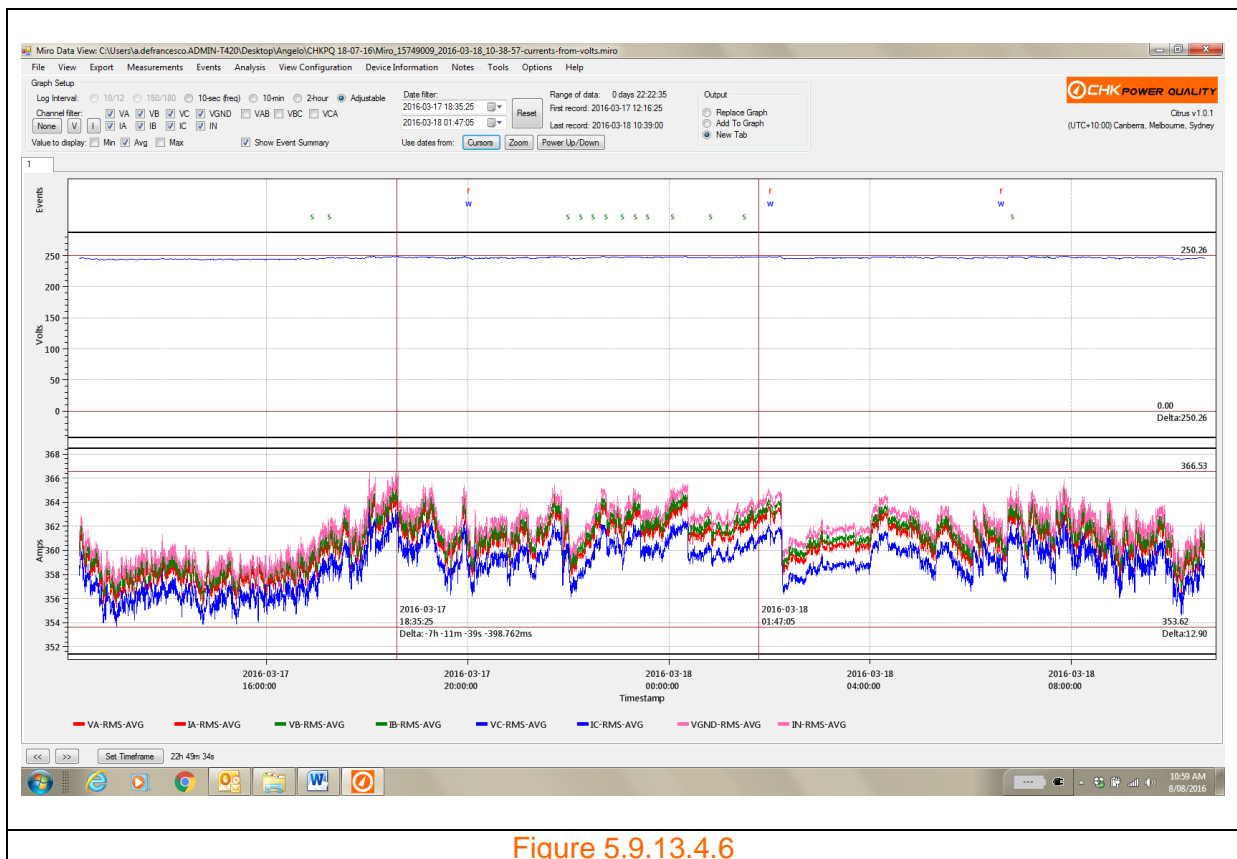

If the user now refreshes the existing graph with an updated measurement, for example TRMS, the graph now displays only that portion as specified by the start and finish date-times and is shown in figure 5.9.13.4.7.

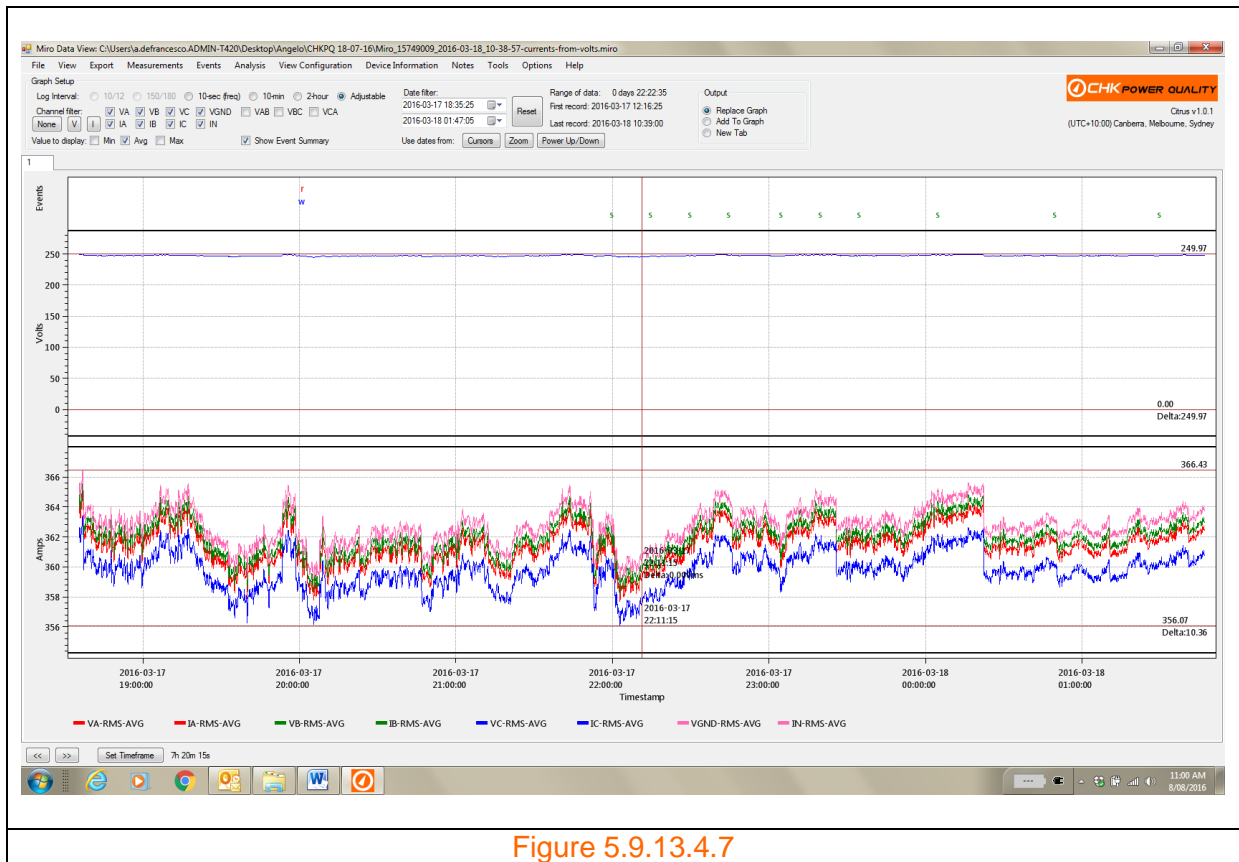

Zoom

The user can update start and finish the date-times by selecting a portion of the graph using the mouse, as shown in figure 5.9.13.4.8, and then clicking on the 'Zoom' button. The start and finish date-times will now reflect the portion of the display selected by the zoom as shown in figure 5.9.13.4.9.

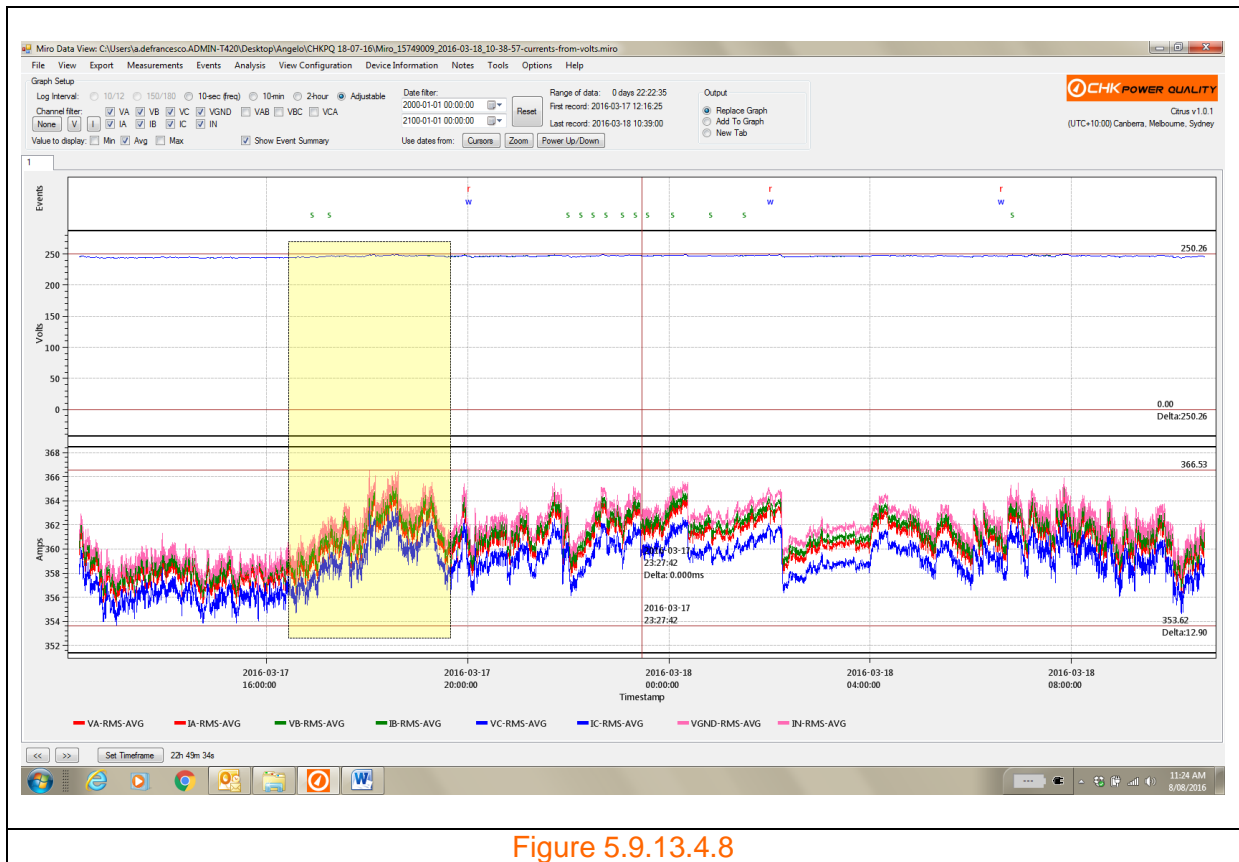

Figure 5.9.13.4.8

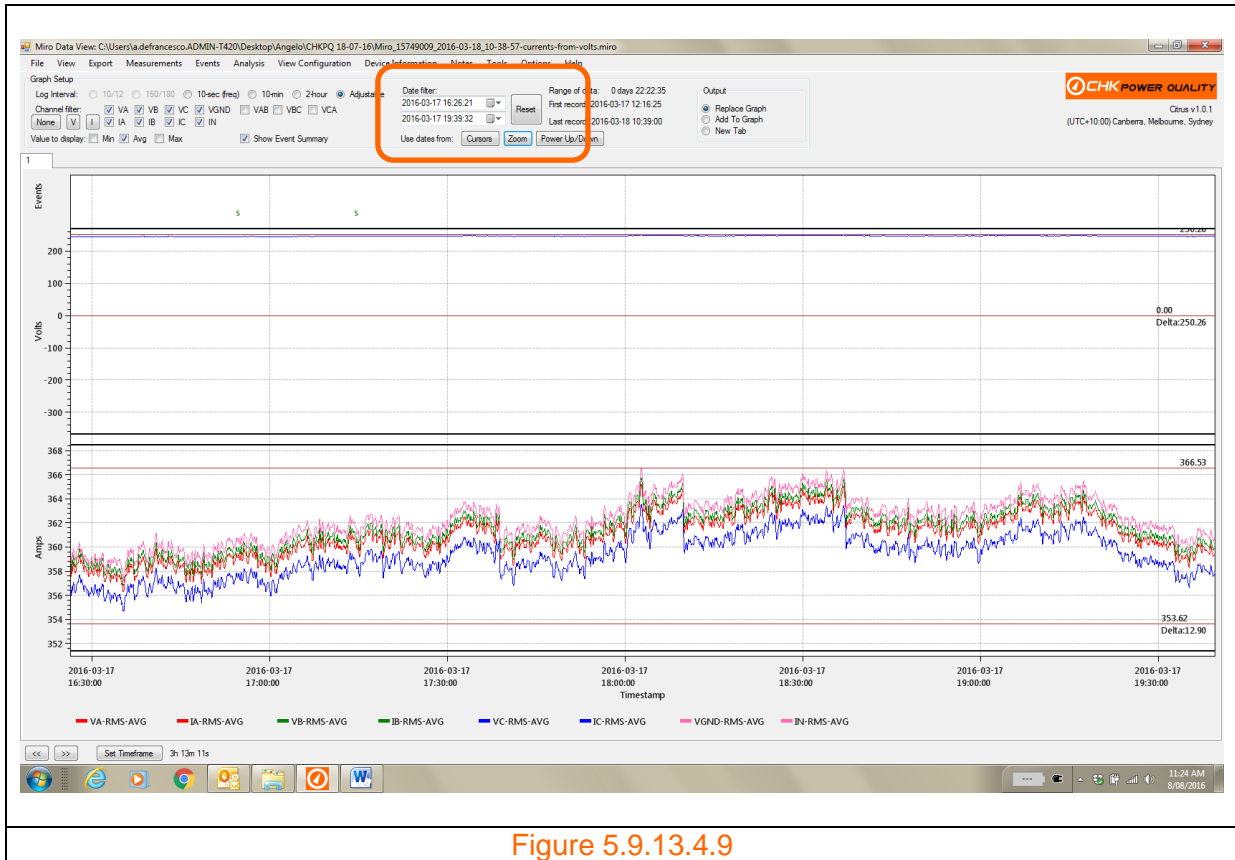

Figure 5.9.13.4.9

Power up / down

This feature is only active if there exists a power up or power down event logged. If the user attempts to use this feature by clicking on 'Power Up/Down' button, the message box as shown in figure 5.9.13.4.10 appears.

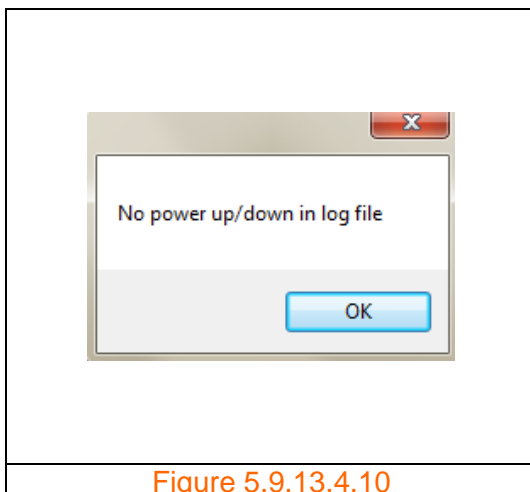

Figure 5.9.13.4.10

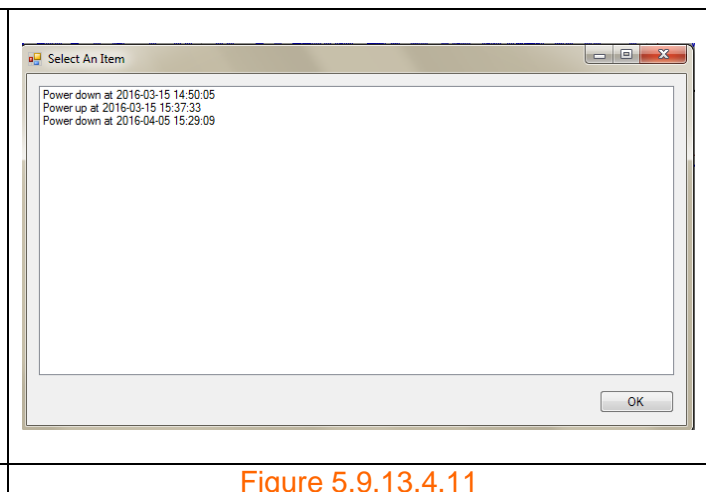
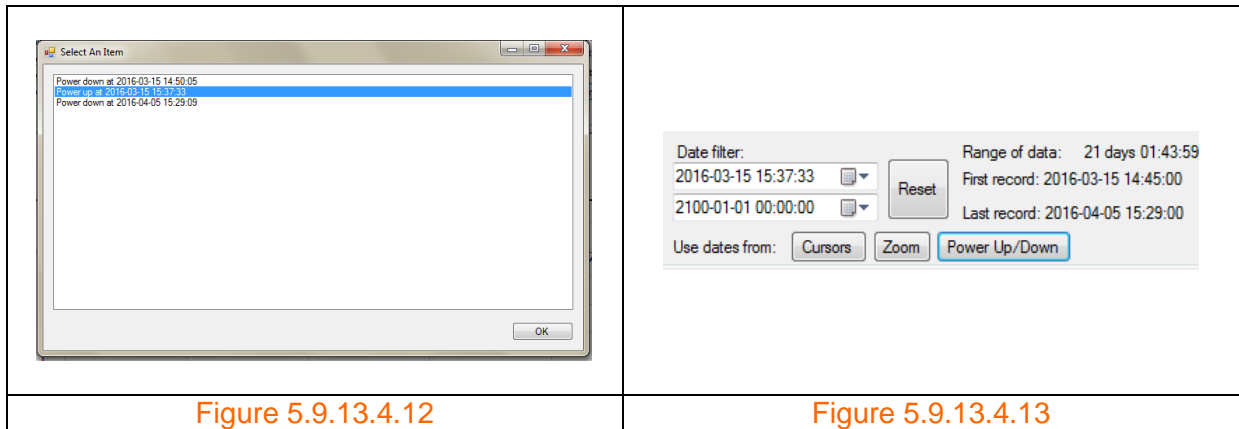

Figure 5.9.13.4.11

In a file where power up or power down events are logged, then clicking on 'Power Up/Down' button will generate a list box showing all the power up and power down events as shown in figure 5.9.13.4.11.

Select the desired power up event as shown in figure 5.9.13.4.12. The start date-time is now updated as shown in figure 5.9.13.4.13.



Again, click on the 'Power Up/Down' button to generate a list box showing all the power up and power down events. Select the desired power down event as shown in figure 5.9.13.4.14. The finish date-time is now updated as shown in figure 5.9.13.4.15.

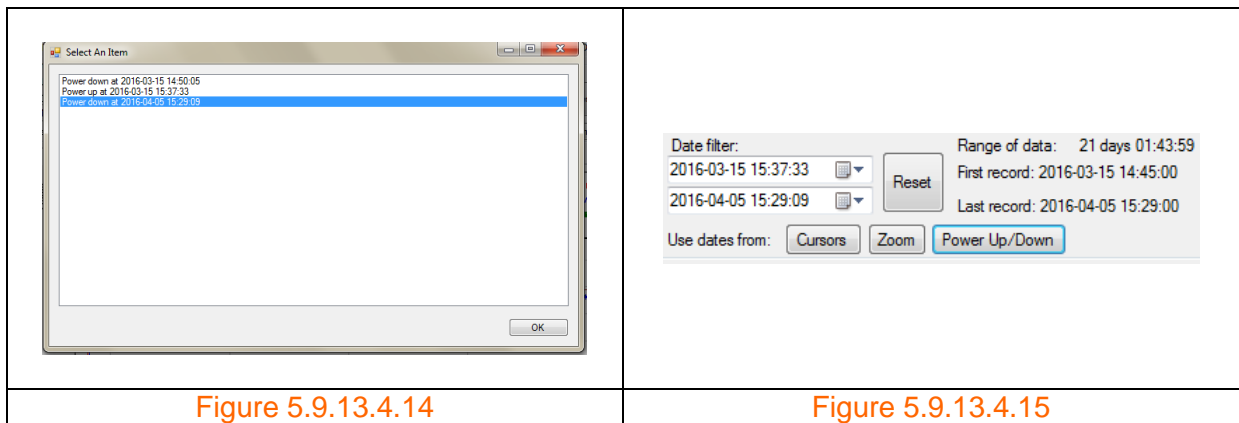

Reset

The user can set the date-times back to the default settings by clicking on the 'Reset' button.

5.9.13.5 Graphical output

The user has various options, shown in figure 5.9.13.5.1, as to how to update measurement views.

'Replace Graph': updates the current graph with new measurement data;

'Add To graph': appends new measurement data on existing graph with previous measurement data; and

'New Tab': New measurement data on a new graph on a new tab.

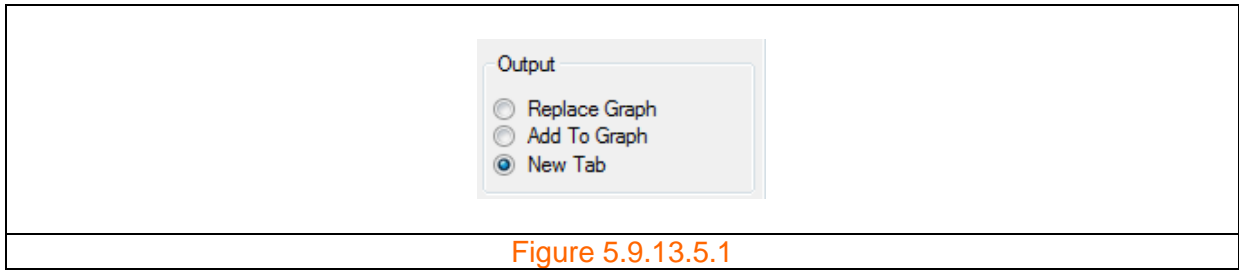

Figure 5.9.13.5.1

5.9.13.6 Timeframes

The timeframe of the display can be adjusted using the tools shown in figure 5.9.13.6.1 at the bottom left hand corner beneath the display. These tools which include a left arrow, right arrow and 'Set Timeframe' buttons are highlighted in figure 5.9.13.6.2.

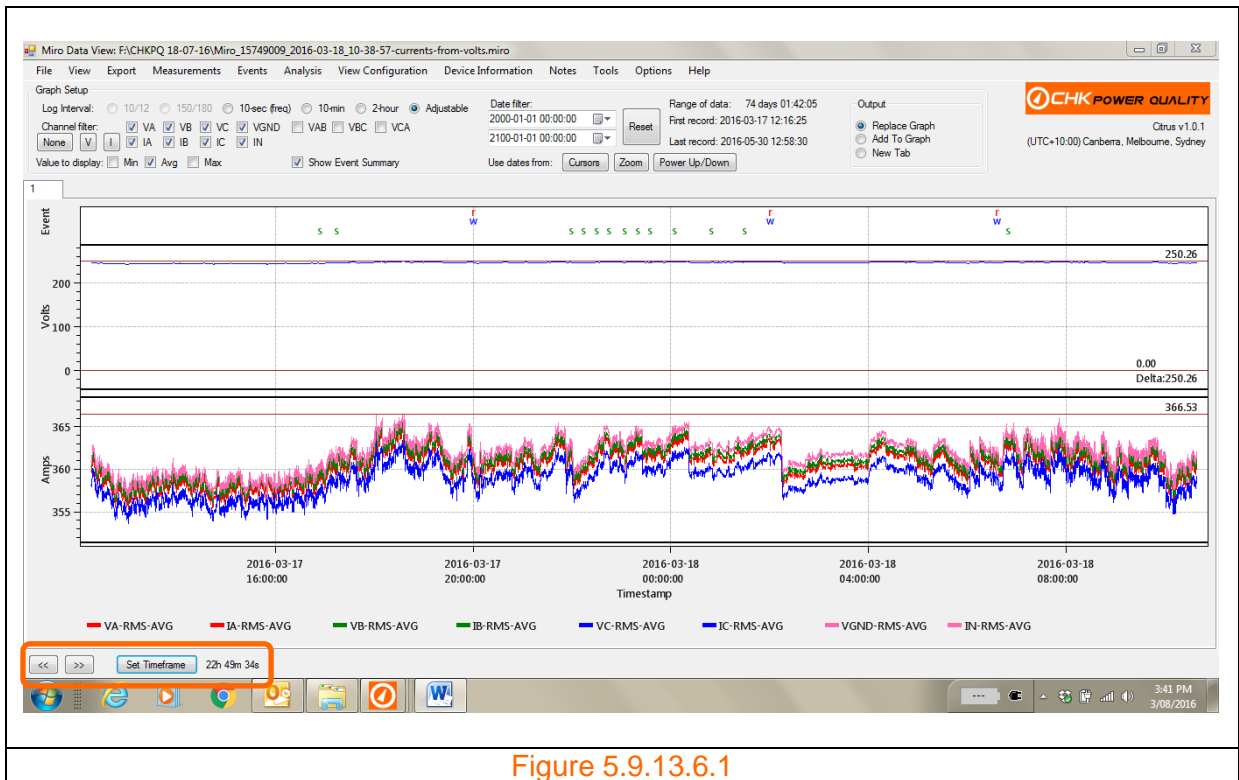

Figure 5.9.13.6.1

The user can set the display to view particular timeframes and include: Hour; Day; Week; and Month and which can be selected from a list, shown in figure 5.9.13.6.3, which appears upon clicking the 'Set Timeframe' button shown in figure 5.9.13.6.2.

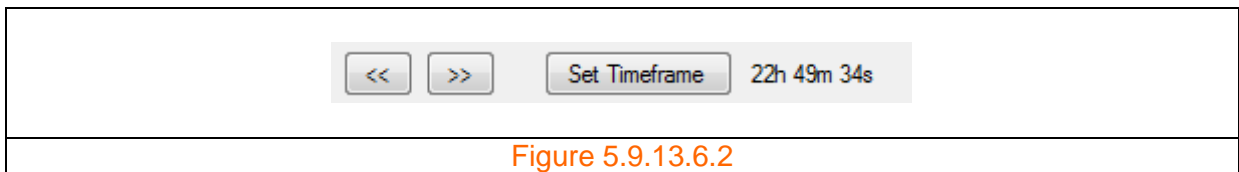

Figure 5.9.13.6.2

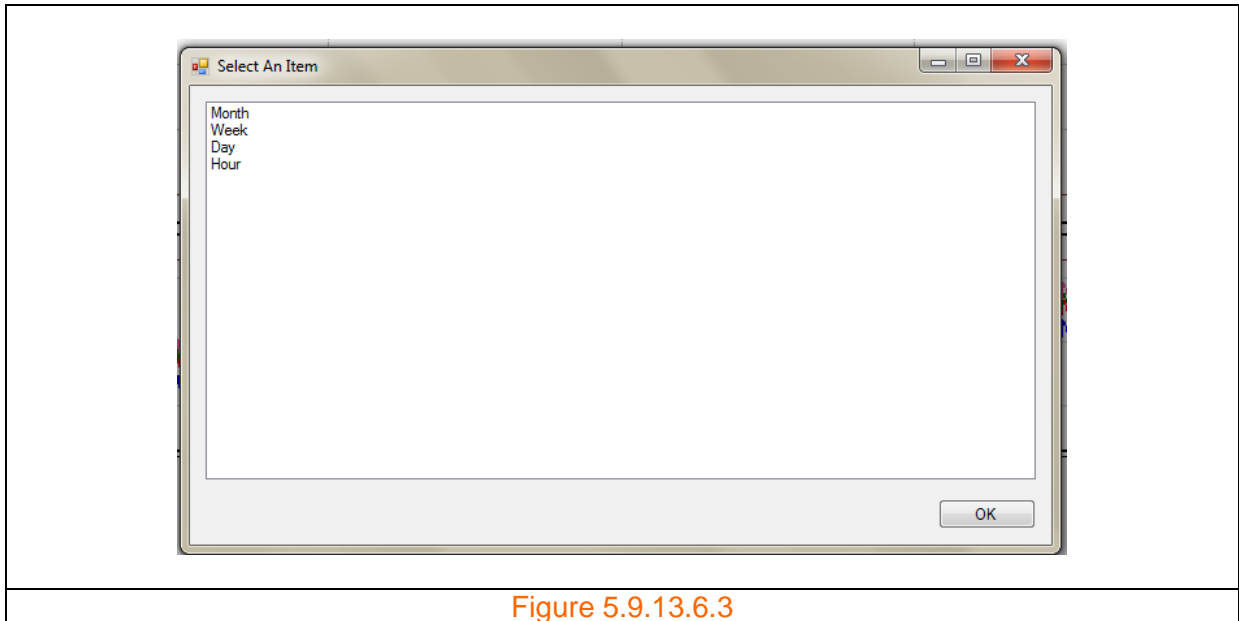

Figure 5.9.13.6.3

For example, selecting 'Hour' from the list will set the time frame to hourly as shown in figure 5.9.13.6.4.

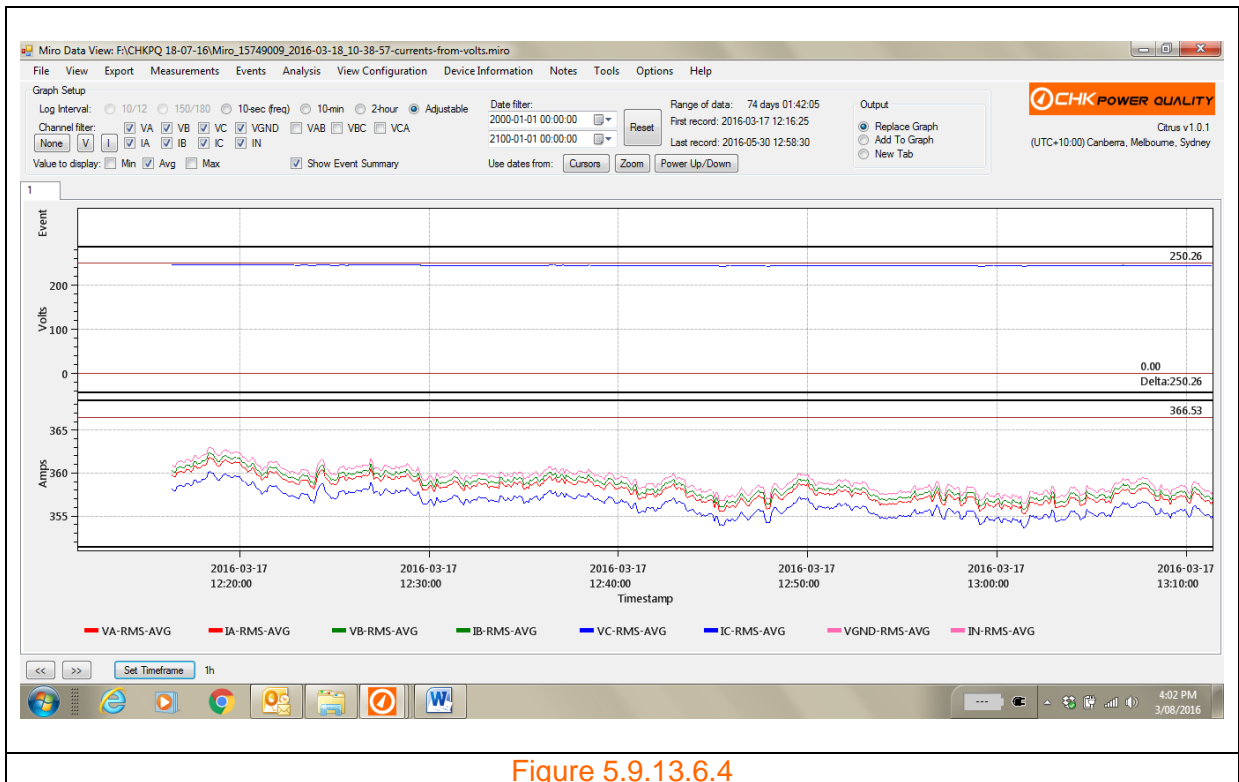

Figure 5.9.13.6.4

Clicking on the left arrow or right arrow buttons will shift the displayed timeframe to the left or right by the set timeframe interval; in this case, hourly intervals.

5.9.13.7 Event summary

As shown in figure 5.9.13.7.1, the top of each graph has an **event summary** which quickly summaries the types of events and when they occurred in time.

Event types

- f RMS event
- w Waveform event
- s Mains signalling event
- ▲ Power up event
- ▼ Power down event

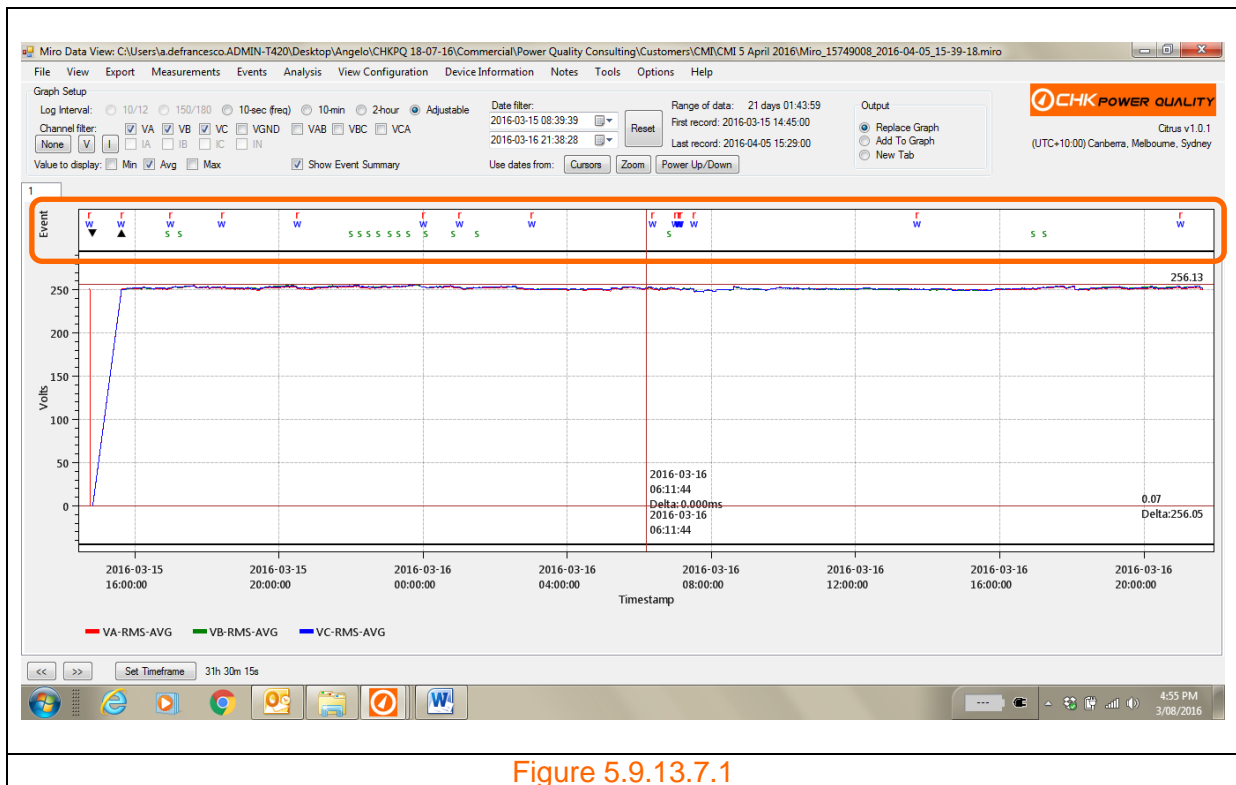

Figure 5.9.13.7.1

The user is able to hide the event summary by unchecking the **'Show Event Summary'** box as shown in figure 5.9.13.7.2.



5.9.14 Version number

The Citrus software version number is located underneath the logo as shown in figure 5.9.14.1.

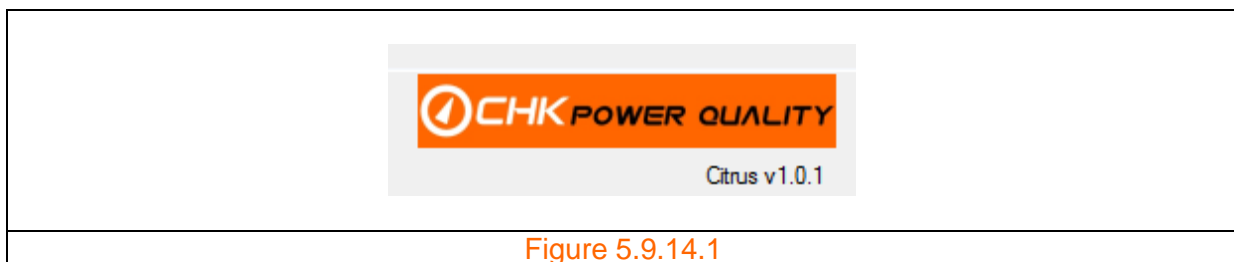

5.10 Offline configuration

The user is able to setup a configuration file without first connecting to the Miro.

Step 1: Click on the Citrus icon, shown in figure 5.10.1, in the start menu or double click on the Citrus icon on the desktop to launch the application. The application form 'Citrus v1.01' shown in figure 5.10.2 will appear. Note that the '1.01' is the software version number and will change over time.

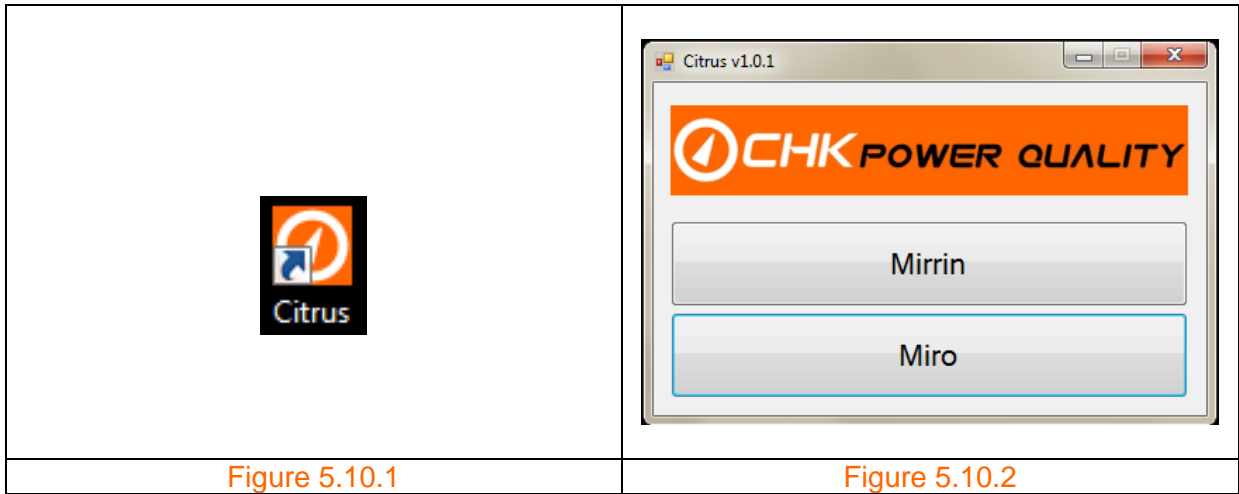

Step 2: Click on the 'Miro' button. The application form shown in figure 5.10.3 will appear.

Step 3: Click on the 'Offline Configuration' button. The configuration form shown in figure 5.10.4 appears.

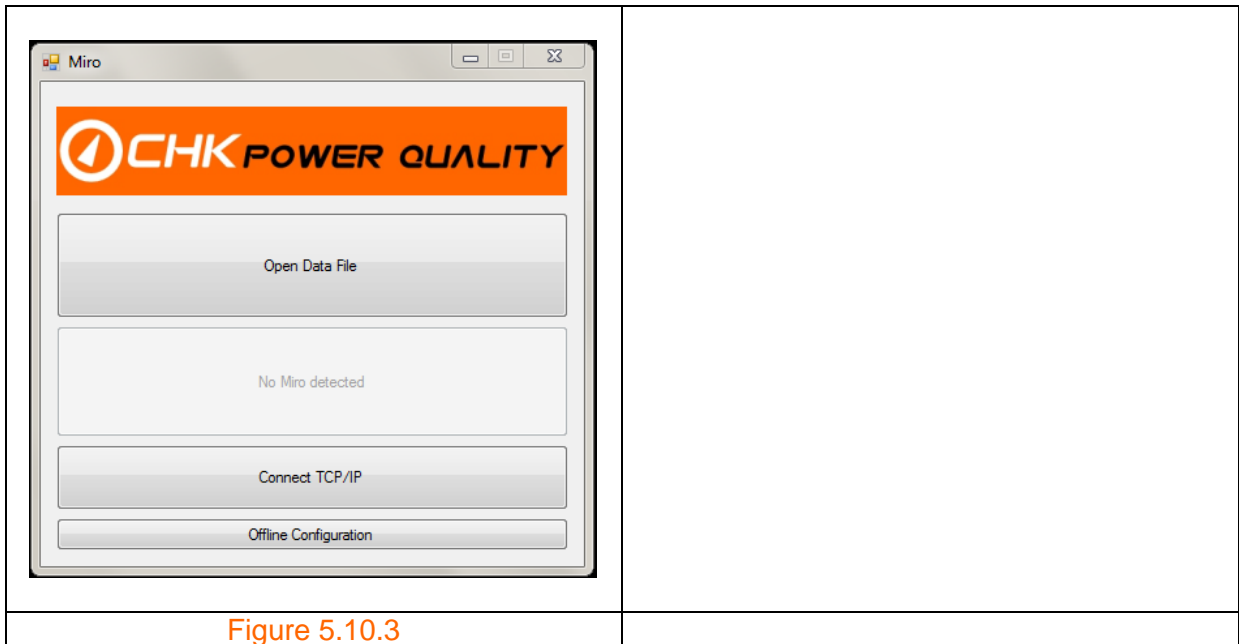

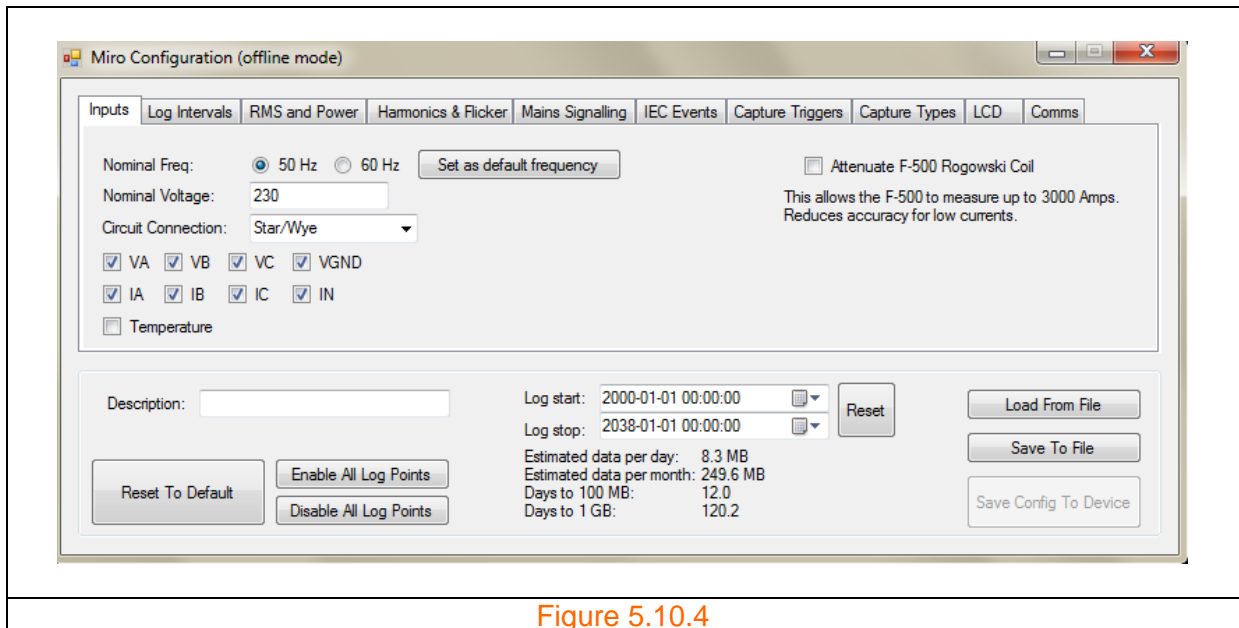

Figure 5.10.4

6 Troubleshooting

6.1 The Miro does not start up after applying power

Fault: The Miro PQ25/35/45 instrument has been powered but the graphic LCD remains off.

Checks:

- 1: The voltage lead is properly connected to the voltage connector on the instrument;
- 2: The voltage lead is connected to a suitable power source;
- 3: Fuses on the voltage leads are not blown. Remove the voltage lead from all mains power and then disconnect the voltage lead connector from the instrument. Use a continuity tester and refer to the voltage lead wiring diagrams provided in Section 15.

Note that the PQ25/35/45 is powered from the A phase. At least 60V is required for the instrument to start-up.

6.2 The Miro does not display voltage and/or current values

Fault: The graphic LCD does not display voltage and current measurements.

Checks:

- 1: Use Citrus to configure the graphic LCD.

6.3 The Miro displays incorrect voltage/current values

Fault: Incorrect voltage and current measurements.

Checks:

- 1: Ensure that the voltage clamps and current probes are connected to the correct inputs and phases and in the correct orientation.
- 2: Check the connectors on the voltage lead and current probes for broken, loose, or dislodged pins. If damage is found, do not use the unit. Return the faulty unit to CHK Power Quality Pty Ltd or your supplier.
- 3: Check that the current probe pole faces are free of dirt or rust. A poorly-maintained current probe may cause measurement errors.
- 4: Check for faulty signal inputs on the Miro by swapping the voltage or current inputs and checking the displayed value.
- 5: Check for faulty current probes by swapping the current inputs and checking the displayed value.

6.4 The Miro LCD shuts down immediately after removing power

Fault: The graphic LCD switches off immediately after removing any power source. When power is removed from the Miro, the LCD should remain active for five (5) minutes.

Checks:

1: The Miro has an internal battery that maintains power during this power-off period. This battery normally discharges gradually over time. To recharge the internal battery, connect the Miro to a power source (mains or external DC) for twenty four (24) hours. If the problem persists, the battery may need replacing and you should return the Miro to CHK Power Quality Pty Ltd.

6.5 The Miro does not communicate with the PC using Citrus software

Fault: Citrus cannot connect to the Miro.

Checks:

- 1:** Check that the data cable is connected to the Miro data connector and to the PC USB 2.0 port.
- 2:** Check that no pins on the Miro data cable are broken, loose, or dislodged.
- 3:** Check that the Miro is powered and functioning.
- 4:** Check that the USB driver is correctly installed. On Windows 7, under Device Manager, Miro will be listed as "PQA" under "PQ Device". Contact CHK if the device is not listed, or if it shows a warning or error sign. Provide a screenshot if possible.

6.6 The Miro date and time are not correct

Fault: Incorrect date and time.

Checks:

- 1:** The Miro clock can be set using the Citrus software.
- 2:** The internal clock is maintained during power-off periods by an internal battery which may be malfunctioning.

7 Support services

7.1 Operational information

If you have questions regarding the operation of the Miro PQ25/35/45 instrument or the Citrus software and not covered by this user manual then please contact our Technical Services Manager.

7.2 Firmware and software upgrades

The Miro PQ25/35/45 is a complex instrument which utilises embedded firmware and PC based software (Citrus). CHK Power Quality Pty Ltd occasionally release firmware upgrades for the Miro PQ25/35/45 and new versions of Citrus. It is recommended to download and install the latest updates.

The current version of firmware and software for the Miro is available for downloading from our downloads page at <http://www.chkpowerquality.com.au/downloads/>

Users who have electronically registered with CHK Power Quality Pty Ltd will be notified of firmware upgrades and new versions of Citrus.

7.3 Technical sales and assistance

The Miro PQ25/35/45 instrument is designed and manufactured by CHK Power Quality Pty Ltd and is currently located at Unit 102, 25 Angas Street, Meadowbank, NSW, 2114, Australia. Please see our website for up-to-date contact information.

If you are experiencing any technical issues, or require any assistance with the proper use or application of this instrument, please contact our Technical Services Manager.

7.4 Calibration

We recommend that the Miro instrument be recalibrated every twelve (12) months.

Please note that only CHK Power Quality Pty Ltd has the know-how to recalibrate the Miro instrument. Other institutions can only provide a calibration check. Therefore the Miro instrument must be returned to CHK Power Quality Pty Ltd for recalibration.

7.4.1 Acceptance testing

Notes for customers who intend to verify the calibration accuracy of the Miro instrument.

7.4.1.1 Voltage calibrators

The Miro can draw up to 15VA on phase A which equates to approximately 65mA at 230V. Voltage calibrators are designed to source much lower currents, in the vicinity of less than 10mA to maintain their accuracy and voltage stability.

Operating the calibrator outside its intended operating limits by loading it with 15VA will most likely affect the calibrator as follows:

- Operation outside of specification;

- Significantly distort the output voltage waveform; and
- Degradation of voltage stability.

By connecting a reference meter in parallel with the Miro, errors can range from 0.1% up to 1% or more, rendering this method unsuitable for verifying the accuracy of a Miro.

Example

Figure 7.4.1.1.1 shows an essentially pure sinusoidal waveform from an unloaded voltage source.

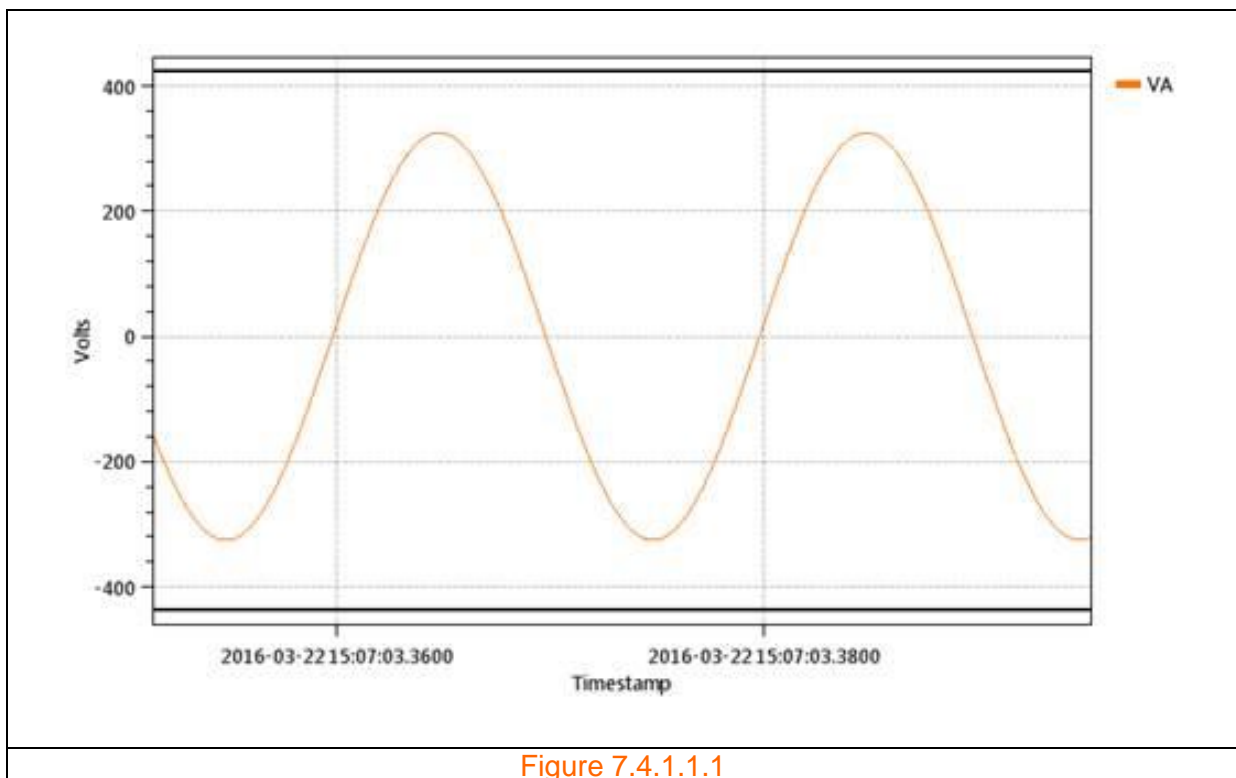

A reference meter measured the RMS of figure 7.4.1.1.1 as 229.996V. As shown in figure 7.4.1.1.2, the RMS voltage is very stable.

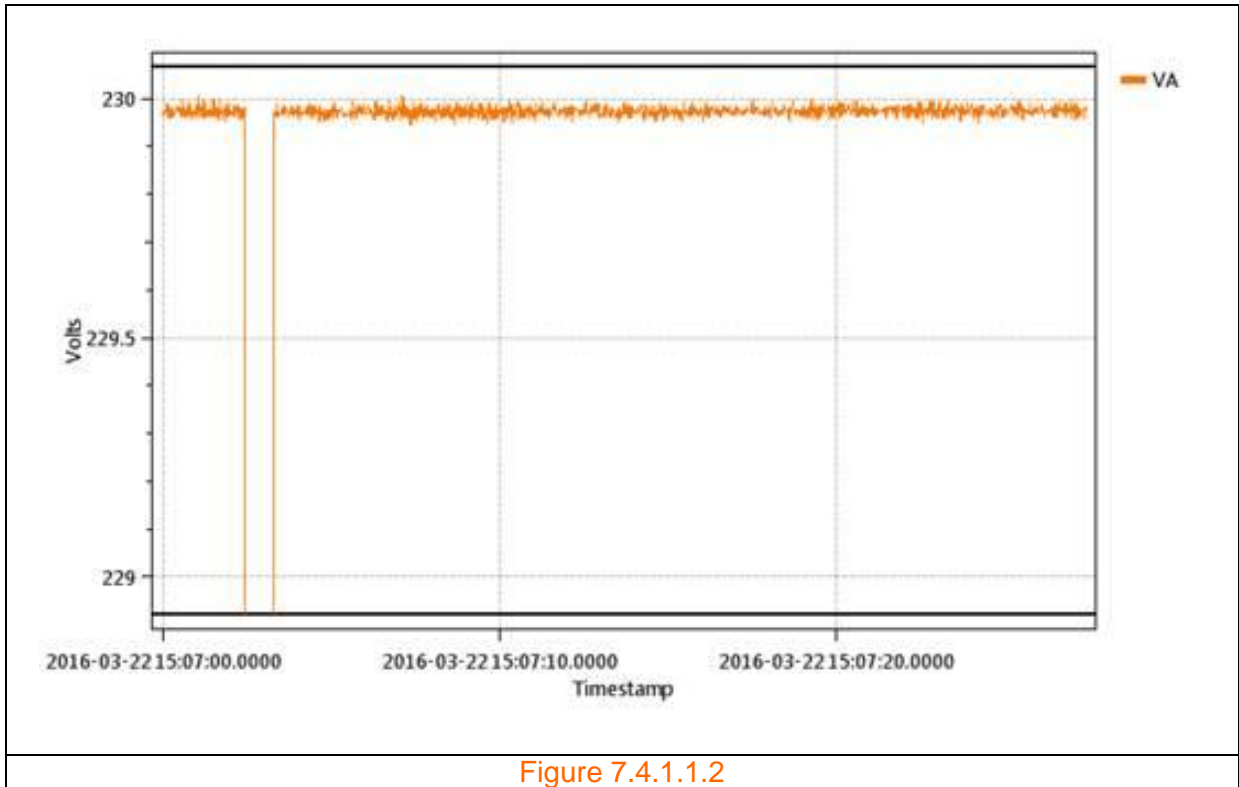

Figure 7.4.1.1.2

Figure 7.4.1.1.3 shows the waveform distortion when the voltage source is connected to phase A of the Miro instrument.



Figure 7.4.1.1.3

A reference meter measured the RMS of figure 7.4.1.1.3 as 229.537V, and varying during the measurement. The varying and drifting voltage can be seen in figure 7.4.1.1.4.

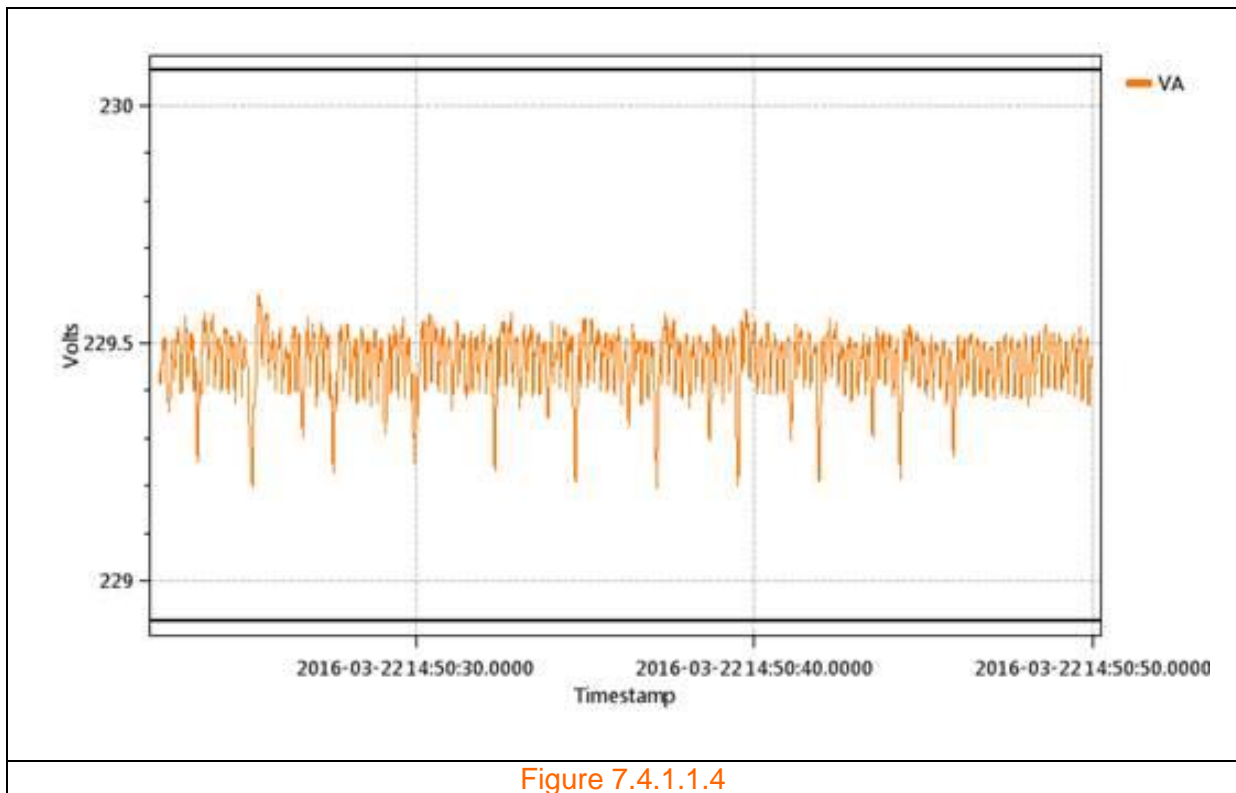

Figure 7.4.1.1.4

The graphs show that loading by the Miro affects the performance of the voltage source and results in a voltage error of 0.2%.

Clearly, the above setup is not suitable to verify the accuracy of a class A Power Quality meter that requires voltage accuracy better than 0.1%.

7.4.1.2 Suitable voltage sources

Ideally a source designed to supply greater than 15VA and remain stable should be used with a reference meter. THD should also be checked during calibration. If THD is more than 1% then the source is not suitable. The displayed reading should also be checked for stability; a variation of no more than 0.05V over 30 seconds is recommended.

The reference meter must be connected at the same time and the Miro reading compared to that of the reference meter rather than to the display of the calibrator.

We can recommend suitable test equipment.

7.5 Equipment maintenance

Enclosure of the Miro instrument should be inspected for mechanical damage leading to cracking in the case. The integrity of the lid seal should also be inspected.

7.6 Cleaning and decontamination

The case of the Miro instrument can be cleaned with a cloth moistened with Isopropyl Alcohol. There are no decontamination issues.

8 Instrument specifications

8.1 Hardware specifications

PARAMETER	COMMENT/DESCRIPTION
Power quality parameters	
Class A declared/nominal input	230V 50Hz/60Hz
Power frequency	IEC61000-4-30 (section 5.1).
Magnitude of the supply voltage	IEC61000-4-30 (section 5.2).
Flicker	IEC61000-4-30 (section 5.3).
Supply voltage dips and swells	IEC61000-4-30 (section 5.4).
Voltage interruptions	IEC61000-4-30 (section 5.5).
Supply voltage unbalance	IEC61000-4-30 (section 5.7).
Voltage harmonics	IEC61000-4-30 (section 5.8).
Voltage interharmonics	IEC61000-4-30 (section 5.9).
Mains signalling voltage on the supply voltage	IEC61000-4-30 (section 5.10).
Rapid voltage changes (RVC)	IEC61000-4-30 (section 5.11).
Underdeviation and Overdeviation	IEC61000-4-30 (section 5.12).
Measurement	
A to D Conversion	16 bits.
Samples per cycle	384 @ 50 Hz; 320 @ 60 Hz.
Sampling Rate	Nominal: 19.2kHz synchronised to mains.
Anti-aliasing	High-frequency components attenuated by at least 50dB so as not to interfere with harmonic measurements.
Measurement metrics	
- Frequency	Range: 50Hz nominal (42.5-57.5)Hz, 60Hz nominal (51.0-69.0)Hz; Measurement: 10s; Accuracy: ± 5 mHz referenced to RTC, ± 1 mHz referenced to GPS.
- Magnitude of the supply voltage (true RMS)	Measurement: 10/12 cycle rms Range: 10% to 150% of nominal value with accuracy of $\pm 0.1\%$ of nominal value under conditions specified in IEC61000-4-30 section 6.1.
- Flicker	IEC61000-4-15, 10 minute Pst (short term) and 2hr Plt (long term).
- Dips and swells	Measurement: 1-cycle rms updated every half cycle. Accuracy: $\pm 0.2\%$ of nominal value, ± 1 cycle. Range (magnitude) 0 to 200%. Range (duration) minimum 0.5 cycles by definition. No upper limit.
- Voltage interruptions	Measurement: 1-cycle rms updated every half cycle. Accuracy: ± 1 cycle. Range (duration) minimum 0.5 cycles by definition. No upper limit.
- Voltage and current unbalance	Applicable 3 phase systems and evaluated using the method of symmetrical components. Metrics: $u_2 = (U_2/U_1)$ and $U_0 = (U_0/U_1)$. U_0 , U_1 and U_2 are sequence components. Range: 0.5% to 5% of U_2 and U_0 . Accuracy: $\pm 0.15\%$.
- Power meter	Power-kW, Power-kVA, Power-kVAR, True Power Factor (TPF), Displacement Power Factor (DPF).
- Voltage harmonics / interharmonics	IEC61000-4-7, Class I (up to 50 th harmonic). Range: 10% to 200% of Class 3 electromagnetic environment in IEC 61000-2-4. Metrics: voltage and current magnitude and angle.
- Total harmonic distortion	51 st to 100 th : Indication only. IEC61000-4-7, THDS (up to 50 th harmonic)

<ul style="list-style-type: none"> (THD) - Mains signalling (Ripple amplitude) - RVC - Underdeviation / Overdeviation - Crest factor - Temperature 	<p>Signal: <3kHz, user specified frequency. 20Hz bandwidth (4-nearest-bins method, adjusted automatically to correct for fundamental drift). Measurement: 10/12 cycle rms amplitude maximum value. Measurement range: 0%-15% of the nominal value. Detection threshold: >0.3% of nominal voltage, Duration: user defined from 1s to 300s. Trigger input to Ripple capture. RVC threshold: user defined between 1% and 6% of the nominal value. RVC hysteresis: user defined and < RVC threshold. Separately measure voltages above and below the nominal value. Metrics: RMS-under, RMS-over, %U_{Under} and %U_{Over}. Indicates peak-to-rms ratio of waveform. ±1%. Two temperature channels measured each second, recording at adjustable, 10-min and 2-hour intervals. Measurement: -50°C to +150°C. Accuracy: ±1°C.</p>
<p>High speed event recording Triggers</p> <p>Event waveform capture</p> <p>Event RMS capture (half cycle RMS) Ripple capture (10/12 cycle RMS)</p>	<p>User defined. Sliding reference, Dip/Swell, transient (dv/dt), manual (via Online Monitor) User defined. Pre-trigger: 100ms; Post trigger: 400ms; Option for extended capture (eg. motor start). Duration: 2s. 2.5s pre trigger, 25s post trigger (50Hz) Duration: 1s to 300s. Triggered by exceedance of detection threshold (see above).</p>
<p>Communications Wired data (standard) Wireless (options)</p>	<p>USB 2.0. Local and remote wireless options will be available and integrated within the instrument.</p>
<p>Logging Logged data memory Logging intervals</p> <p>Measurements GPS location</p>	<p>8GB. All IEC61000-4-30 intervals simultaneously plus adjustable interval from 1s to 3600s. All measurements simultaneously. GPS location coordinates logged periodically.</p>
<p>General Circuit connections</p> <p>Data file Data display</p> <p>Software tools</p>	<p>Three phase delta, three phase Wye, split phase* & single phase. PQA format binary with CSV export. Real time measurements of basic parameters via LCD, all parameters via Online Monitor. CITRUS.</p>
<p>Inputs</p> <ul style="list-style-type: none"> - Voltage channels (AC/DC) - Voltage range (working maximum per isolated input pair) - Voltage surge protection (differential) - Current channels (AC/DC) - Current range - Temperature channels - Expansion Module Port 	<p>Isolated. 3 or 4 independent 2-wire inputs depending on model and voltage lead options. Powered from phase A: 600VACrms (850Vpk) Internal supply disabled: 700VACrms (1000Vpk) 4kV Fast transients, 6kV 1.2/50us impulse – no effect. Recalibration may be required after impulses significantly exceeding 6kV. 4. Hall effect clamp-on sensor required to measure DC. Dependent upon current sensor. 2 x PT100 RTD, M8 connectors. UART / SPI interface for future system upgrade. Allows for</p>

<ul style="list-style-type: none"> - Accessories 	<p>additional sensors (e.g. current, voltage, temperature, DGA), analogue I/O (e.g. 4-20mA/0-5V/0-10V), digital I/O and relays. Compatible with PM35 and PM45 accessories. Temperature sensors are PT100 RTD Class B. IEC61000-4-30, Class A. Flexible current sensors or clamp-on current probes with automatic detection.</p>
<p>Instrument type Current Sensors</p>	<p>22°C. ±0.2% of full scale. System accuracy depends on sensor. ±0.1% of nominal value as specified above. Approx 25ppm/C</p>
<p>Accuracy Reference conditions Current (instrument) Voltage Voltage temperature coefficient</p>	<p>Indoor and outdoor. Up to 2000m. -20°C to +85°C. 20% to 99% Relative Humidity. IP66 (all weather housing).</p>
<p>Environment and safety Use Altitude Operating Temperature Relative Humidity Degree of Protection</p>	<p>Certifications / type testing EN55022:1998 _A1:2000 +A2:2003 CLASS A. MIL STD 810 G. IEEE 495:2007 or equivalent. MIL STD 810 G. IEEE 495:2007 or equivalent. IEC 61010-1, Pollution degree 3; CAT IV 600V (PQ45 model), >10kV withstand.</p>
<p>Power Power supply USB powered (Mini USB) External DC supply Backup power Backup battery duration</p>	<p>Phase A voltage, range: (60-600)VACrms; 15VA typical. Configuration and download. Plug pack provided. Rechargeable battery - LiFePO₄. 5 minutes. Longer duration (30 minutes with 24 hours recharge) available on request.</p>
<p>Timing Real time clock (RTC) battery</p>	<p>Non rechargeable Lithium backup battery. Functional life: > 10 years. Typical ±3ppm from -15 to 60C. Drift <1 second per week. Time accuracy: <1ms. External antenna required.</p>
<p>RTC GPS (internal)</p>	<p>Colour graphic LCD (4.3" 480x272 Graphic TFT LCD); Dimensions: (97 x 56) mm. (180 x 130 x 60) mm; Length side ports: Current and voltage channels; Width side ports: Data, temperature and expansion module i/o connectors.</p>
<p>Mechanical Display</p>	<p>1.05kg (instrument only). Polycarbonate, moulded in light grey. Soft flexible boot for protection.</p>
<p>Enclosure dimensions</p>	<p>Weight Case material and colour Boot</p>

8.2 Software features

FEATURE	COMMENT/DESCRIPTION
General	
Software platform	CITRUS - A new single software platform used to manage all company products.
Application launch	Automatically when clicking on a CITRUS file.
Configuration	
Select All button	Option to select "All" (log all parameters).
Output	
Custom CSV file	Export menu provides ability to choose specific parameters to export as part of the CSV file.
Data export*	Export data file in "PQDIF" compatible format and other (upon request).
Remote communications	
Logging whilst downloading	No interruption to logging whilst logged data is being downloaded.
Graphs/Charts	
	All logged parameters. Can overlay multiple parameters and data from multiple files. Export any graph to table
Tables	
Metrics	
Voltage percentile performance indices	Metrics: $V_{0\%}$, $V_{1\%}$, $V_{50\%}$, $V_{99\%}$, $V_{100\%}$. Voltage Spread: $V_{99\%}$ - $V_{1\%}$. (Log interval: 10 minute, duration: 1 week).
K Factor*	Includes 1 st to 50 th harmonics.
Triplen harmonics	Able to display Triplen currents.
Harmonic direction	Display direction for selected harmonics, and referenced to the direction of the Power frequency.
Symmetrical components	For 3 phase configurations, display of symmetrical components, zero, positive and negative sequences.
Views	
Annotate views	Ability to insert comments on views and save.
PDF Export	Save view with cursors and annotations to PDF
Hide/unhide channels	Ability to hide channels on views
Cursors	Horizontal and vertical. Tied to data; location persists when zooming.
GPS location	GPS location coordinates.
Save views	Ability to save desired view and or a composite file.
Print views	Ability to print views.
(Online) Real-time monitoring	Ability to view all parameters plus waveforms in real-time.
Reports (Analysis package)	Reports Menu for generating predefined reports.
- Frequency spectra table	Amplitudes of harmonics at a desired time or time interval. Allow harmonic selection.
- Frequency spectra	Chart: Amplitude versus harmonics at a desired time or time interval. Allow harmonic selection.
- Compliance	Various reports
- Custom	Upon request.
Tools	
Energy calculator	

*Will be available with future software upgrades.

9 Accessories

9.1 Voltage leads

9.1.1 Single phase leads

The PC4 and PC5 single phase leads shown in figures 9.1.1.1 and 9.1.1.2 are intended for single phase measurements. The PC4 and PC5 leads connect via a standard general purpose outlet (GPO) and are designed for indoor use only. The PC4 is used to power the PQ25 and PQ35 whilst the PC5 is used to power the PQ45 from the Phase A to Neutral connection and accordingly monitors and measures single phase voltage.



Figure 9.1.1.1

Single phase lead

Part number: 1APC4.

Instrument: PQ25 and PQ35.

Connection: Single phase.

Power source: Phase A to Neutral.

Termination: 3 pin Australian GPO plug.

Number of wires: 3 (1 phase + N + G).

Weight: 200g.

Cable length: 2m.

Environment: Indoor.



Figure 9.1.1.2

Single phase lead

Part number: 1APC5.

Instrument: PQ45.

Connection: Single phase.

Power source: Phase A to Neutral.

Termination: 3 pin Australian GPO plug.

Number of wires: 3 (1 phase + N + G).

Weight: 350g.

Cable length: 2m.

Environment: Indoor.

9.1.2 Three phase leads

Three phase leads connect to live power systems. Connections should only be made by appropriately qualified operators. Appropriate personal protective equipment must be used when making live connections.

If the clamps are wet or are installed or removed in rainy conditions, it is recommended that extra safety precautions are followed. As a minimum, this includes the use of appropriately rated insulated gloves.

If the three phase lead shows any sign of damage or broken insulation, it should not be used. Please return it to CHK Power Quality Pty Ltd or your supplier for repair or replacement.

Never connect the Active or Neutral leads to ground / Earth.

9.1.3 PQ35 three phase leads

Three phase leads suitable for the PQ35 are double insulated and UV stabilised and suitable for indoor and outdoor installations. The working voltage between any phase and ground must not exceed 300 V RMS. The working voltage between any two phases must not exceed 520 V RMS.

Each phase of the voltage cable is separately fused and there are various voltage cable attachments available to suit different types of installations.

9.1.3.1 VL3

The VL3 is a three phase three wire lead with Red, White and Blue wires as shown in figure 9.1.3.1.1. The wires are partially terminated with brass contacts and fuse caps. It is intended to be utilised with attachments.

	<p><u>Fused three phase lead</u></p> <p>Part number: 1AVL3.</p> <p>Instrument: PQ25 and PQ35.</p> <p>Connection: 3 phase delta.</p> <p>Power source: Phase A to B.</p> <p>Termination: Fused end.</p> <p>Number of wires: 3 (3P).</p> <p>Weight: 300g.</p> <p>Cable length: 2m.</p> <p>Environment: Indoor / outdoor.</p> <p>Attachments: 1AAC4TE (N not required); 1AAC4BC (N not required).</p>
<p>Figure 9.1.3.1.1</p>	

9.1.3.2 VL4

The VL4 is a three phase four wire lead with Red, White, Blue and Black wires as shown in figure 9.1.3.2.1. The lead is partially terminated with brass contacts and fuse caps. It is intended to be utilised with attachments.

	<p><u>Fused three phase lead</u></p> <p>Part number: 1AVL4.</p> <p>Instrument: PQ25 and PQ35. Connection: 3 phase star/wye. Power source: Phase A to Neutral. Termination: Fused end. Number of wires: 4 (3P + N). Weight: 400g. Cable length: 2m. Environment: Indoor / outdoor. Attachments: 1AAC4TE; 1AAC4BC.</p>
<p>Figure 9.1.3.2.1</p>	

9.1.3.3 VL4 voltage lead attachments

	<p><u>Tinned end fused attachment with fuses</u></p> <p>Part numbers: 1 x AC4TE/BK (Fused tinned end Black); 1 x AC4TE/BU (Fused tinned end Blue); 1 x AC4TE/RD (Fused tinned end Red); 1 x AC4TE/WH (Fused tinned end White); and 4 x FSHD2A10x38 (fuse).</p> <p>The above parts are normally sold in a set as 1AAC4TE.</p> <p>Instrument: PQ25 and PQ35. Connection: Three phase star/wye. Termination: Fused end. Number of wires: 4 (3P + N). Weight: 150g. Cable length: 20cm. Environment: Indoor / outdoor. Attachments: VL3 (AC4TE/BK and one fuse not required), VL4. Fuses: 2A 500V HRC, (10 x 38) mm.</p>
<p>Figure 9.1.3.3.1</p>	



Figure 9.1.3.3.2

Banana plug fused attachment with small clamps (crocodile clips)

Part number: 1AAC4BC.

Instrument: PQ25 and PQ35.

Connection: 3 phase star/wye.

Termination: Fused end.

Number of wires: 4 (3P + N).

Weight: 200g.

Cable length: 20cm.

Environment: Indoor /outdoor.

Attachments: VL3 (N not required), VL4.



Figure 9.1.3.3.3

Large fused clamps (lfc)

Part numbers:

1 x 1AAC1NCL/BK (Black lead with lfc);

1 x 1AAC1NCL//BU (Blue lead with lfc);

1 x 1AAC1NCL//RD (Red lead with lfc); and

1 x 1AAC1NCL//WH (White lead with lfc).

The above parts are normally sold with VL4 as a 1AVL4C2.

Instrument: PQ25 and PQ35.

Connection: 3 phase star/wye.

Termination: Fused end.

Number of wires: 4 (3P + N).

Weight: 600g.

Cable length: 20cm.

Environment: Indoor /outdoor.

Attachments: VL3 (1AAC1NCL/BK not required), VL4.

Fuses: 16A 500V HRC, (10 x 38) mm.

9.1.3.4 VL6

The VL6 is a fused three phase six wire lead that connects to three phase circuits using six banana plugs as shown in figure 9.1.3.4.1. The lead has separate neutrals and intended as a general connection lead for use on all types of power systems.

The VL6 lead measures the Phase A to Neutral A, Phase B to Neutral B and Phase C to Neutral voltages.

The VL6 lead is fused with 2A, high rupture capacity (HRC) fuses. These fuses are an integral part of the VL6 lead and are not user replaceable.

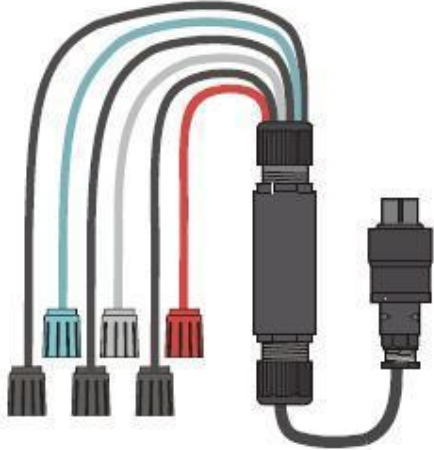
	<p><u>Fused three phase lead</u></p> <p>Part number: 1AVL6.</p> <p>Instrument: PQ25 and PQ35.</p> <p>Connection: 3 phase star/wye or delta.</p> <p>Power source: Phase A to Neutral.</p> <p>Termination: Fused end.</p> <p>Number of wires: 6 (3P + 3N).</p> <p>Cable length: 2m.</p> <p>Environment: Indoor / outdoor.</p> <p>Attachments: 1AAC6TE; 1AAC6BC.</p>
<p>Figure 9.1.3.4.1</p>	

9.1.4 PQ45 three phase leads

Three phase leads suitable for the PQ45 are double insulated and UV stabilised and suitable for indoor and outdoor installations. The working voltage between any phase and ground must not exceed 600 V RMS. The working voltage between any two phases must not exceed 600V RMS.

All PQ45 three phase leads meet protection level CAT IV 600V.

9.1.4.1 VL5-B

The VL5-B is a fused three phase five wire lead that connects to three phase circuits using five banana plugs and five detachable crocodile clips as shown in figure 9.1.4.1.1. The lead has a common neutral (N) shared by all phases.

The VL5-B leads are fused with 2A, high rupture capacity (HRC) fuses. These fuses are an integral part of the VL5-B lead and are not user replaceable.



Figure 9.1.4.1.1

Fused three phase lead with banana plugs and detachable small clamps (crocodile clips)

Part number: 1AVL5-B.

Instrument: PQ45.

Connection: 3 phase star/wye.

Power source: Phase A to Neutral.

Termination: Banana plugs.

Number of wires: 5 (3P + N + G).

Weight: 950g.

Cable length: 2m.

Environment: Indoor / outdoor.

Fuses: 2A 600V HRC, (10 x 38) mm.

Protection level: CAT IV 600V.

Figure 9.1.4.1.2 shows a new addition to the accessories, the 1AVL5-B cable using coloured wires, banana plugs and crocodile clips.



Figure 9.1.4.1.2

Fused three phase lead with banana plugs and detachable small clamps (crocodile clips)

Part number: 1AVL5-B.

Instrument: PQ45.

Connection: 3 phase star/wye.

Power source: Phase A to Neutral.

Termination: Banana plugs.

Number of wires: 5 (3P + N + G).

Weight: 950g.

Cable length: 2m.

Environment: Indoor / outdoor.

Fuses: 2A 600V HRC, (10 x 38) mm.

Protection level: CAT IV 600V.

9.1.4.2 VL5-C

The VL5-C is a three phase five wire lead that connects to three phase circuits using five large fused clamps as shown in figure 9.1.4.2.1. The lead has a common neutral (N) shared by all phases.

The VL5-C clamps are fused with 2A, high rupture capacity (HRC) fuses. These fuses are an integral part of the VL5-C lead and are not user replaceable.



Figure 9.1.4.2.1

Three phase lead with large fused clamps

Part number: 1AVL5-C.

Instrument: PQ45.

Connection: 3 phase star/wye.

Power source: Phase A to Neutral.

Termination: Large fused clamps.

Number of wires: 5 (3P + N + G).

Weight: 1050g.

Cable length: 2m.

Environment: Indoor / outdoor.

Fuses: 2A 600V HRC, (10 x 38) mm.

Protection level: CAT IV 600V.

9.1.4.3 VL8-B

The VL8-B is a fused three phase eight wire lead that connects to three phase circuits using eight banana plugs as shown in figure 9.1.4.3.1. The lead has separate neutrals and intended as a general connection lead for use on all types of power systems.

The VL8 lead measures the Phase A to Neutral A, Phase B to Neutral B, Phase C to Neutral C & Ground to Neutral voltages.

The VL8-B lead is fused with 2A, high rupture capacity (HRC) fuses. These fuses are an integral part of the VL8-B lead and are not user replaceable.



Figure 9.1.4.3.1

Fused three phase lead with banana plugs and detachable small clamps (crocodile clips)

Part number: 1AVL8-B.

Instrument: PQ45.

Connection: 3 phase star/wye or delta.

Power source: Phase A to A Neutral.

Termination: Banana plugs with clips.

Number of wires: 8 (3P + 3N + 2G).

Weight: 1.4kg.

Cable length: 2m.

Environment: Indoor / outdoor.

Fuses: 2A 600V HRC, (10 x 38) mm.

Protection level: CAT IV 600V.

	<p><u>Fused three phase lead with banana plugs</u></p> <p>Part number: 1AVL8.</p> <p>Instrument: PQ45.</p> <p>Connection: 3 phase star/bye or delta.</p> <p>Power source: Phase A to A Neutral.</p> <p>Termination: Banana plugs.</p> <p>Number of wires: 8 (3P + 3N + 2G).</p> <p>Weight: 1.2kg.</p> <p>Cable length: 2m.</p> <p>Environment: Indoor / outdoor.</p> <p>Fuses: 2A 600V HRC, (10 x 38) mm.</p> <p>Protection level: CAT IV 600V.</p>
<p>Figure 9.1.4.3.2</p>	

9.1.4.4 VL8-C

The VL8-C is a three phase eight wire lead that connects to three phase circuits using eight large fused clamps as shown in figure 9.1.4.4.1. The lead has separate neutrals and intended as a general connection lead for use on all types of power systems.

The VL8 lead measures the Phase A to Neutral A, Phase B to Neutral B, Phase C to Neutral C & Ground to Neutral voltages.

The VL8-C clamps are fused with 2A, high rupture capacity (HRC) fuses. These fuses are an integral part of the VL8-C lead and are not user replaceable.

	<p><u>Three phase lead with large fused clamps</u></p> <p>Part number: 1AVL8-C.</p> <p>Instrument: PQ45.</p> <p>Connection: 3 phase star/bye or delta.</p> <p>Power source: Phase A to A Neutral.</p> <p>Termination: Large fused clamps.</p> <p>Number of wires: 8 (3P + 3N + 2G).</p> <p>Weight: 1.6kg.</p> <p>Cable length: 2m.</p> <p>Environment: Indoor / outdoor.</p> <p>Fuses: 2A 600V HRC, (10 x 38) mm.</p> <p>Protection level: CAT IV 600V.</p>
<p>Figure 9.1.4.4.1</p>	

9.2 Current probes

We can customise current probes for specific applications. Please contact our sales team to assist you further.

9.2.1 PQ35 current probes

9.2.1.1 Flexible high sensitivity coil F-500/3000 (Red)



Figure 9.2.1.1.1

Flexible high sensitivity coil F-500/3000 (Red)

Part number: 1AFF3000-6-H.

Instrument: PQ25 and PQ35.

Output signal: 250mV/500A @ 50Hz.

Frequency range: 20Hz to 5kHz.

Accuracy: $\pm 1\%$ (Calibrated).

Linearity: $\pm 0.2\%$ (Calibrated).

Coil length: 600mm.

Weight: 300g.

Cable length: 2m.

Environment: Indoor / outdoor.

Protection level: CAT IV 600V.

Colour: Red.

9.2.1.2 Flexible coil 3000 (Blue)



Figure 9.2.1.2.1

Flexible coil 3000 (Blue)

Part number: 1ACF3000-6 (3000A).

Instrument: PQ25 and PQ35.

Output signal: 100mV/kA @ 50Hz.

Frequency range: 20Hz to 5kHz.

Accuracy: $\pm 1\%$ (Calibrated).

Linearity: $\pm 0.2\%$ (Calibrated).

Coil length: 600mm.

Weight: 300g.

Cable length: 2m.

Environment: Indoor / outdoor.

Protection level: CAT IV 600V.

Colour: Blue.

9.2.1.3 Flexible coil 3000 (Green)

	<p><u>Flexible coil 3000 (Green)</u></p> <p>Part number: 1AFF3000-6 (3000A). Instrument: PQ25 and PQ35. Output signal: 78mV/kA @ 50Hz. Frequency range: 10Hz to 20kHz. Accuracy: $\pm 0.5\%$ (Calibrated). Linearity: $\pm 0.2\%$ (Calibrated). Coil length: 610mm. Weight: 300g. Cable length: 2m. Environment: Indoor / outdoor. Protection level: CAT IV 600V. Colour: Green.</p>
<p>Figure 9.2.1.3.1</p>	

9.2.1.4 Clamp on CT probes 52mm - 100A

	<p><u>Clamp on CT probe 52mm - 100A</u></p> <p>Instrument: PQ25 and PQ35. Part number: 1ACR100.</p> <p>Accuracy: $\pm 0.5\%$. Cable diameter: 52mm. Rated current: 100Arms. Frequency range: 5Hz-5kHz. Weight: 750g. Cable length: 1.95m. Protection level: CAT IV 600V.</p>
<p>Figure 9.2.1.4.1</p>	

9.2.1.5 Clamp on CT probes 52mm - 500A



Figure 9.2.1.5.1

Clamp on CT probe 52mm - 500A

Instrument: PQ25 and PQ35.
Part number: 1ACR500.

Accuracy: $\pm 0.5\%$.
Cable diameter: 52mm.
Rated current: 500Arms.
Frequency range: 5Hz-5kHz.
Weight: 750g.
Cable length: 1.95m.
Protection level: CAT IV 600V.

9.2.1.6 Clamp on CT probes 52mm - 1000A



Figure 9.2.1.6.1

Clamp on CT probe 52mm - 1000A

Instrument: PQ25 and PQ35.
Part number: 1ACR1000.

Accuracy: $\pm 0.5\%$.
Cable diameter: 52mm.
Rated current: 1000Arms.
Frequency range: 5Hz-5kHz.
Weight: 750g.
Cable length: 1.95m.
Protection level: CAT IV 600V.

9.2.1.7 Clamp on CT probes 15mm - 100A

	<p><u>Clamp on CT probe 15mm - 100A</u></p> <p>Instrument: PQ25 and PQ35. Part number: 1ACR100S.</p> <p>Accuracy: ±1%. Cable diameter: 15mm. Rated current: 100Arms. Frequency range: 45Hz-5kHz. Safety rating: 600V CAT III. Weight: 113g (excluding lead). Cable length: 1.95m.</p>
<p>Figure 9.2.1.7.1</p>	

9.2.1.8 Clamp on AC + DC probes 50mm

DC probes are intended for monitoring currents in DC systems.

	<p><u>Clamp on AC + DC Probe 50mm</u></p> <p>Instrument: PQ25 and PQ35. Part number: 1ADCR500.</p> <p>Cable diameter: 50mm. Rated current: 500A. Upper frequency: 10kHz (-3dB). Safety rating: CAT III 600V. Power source: Directly from the Miro (no external power supply required). Weight: 600g; Cable length: 2m.</p>
<p>Figure 9.2.1.8.1</p>	

9.2.2 PQ45 current probes

9.2.2.1 Flexible high sensitivity coil F-500/3000 (Red)

	<p><u>Flexible high sensitivity coil F-500/3000 (Red)</u></p> <p>Part number: 1AF3000-6-H.</p> <p>Instrument: PQ45.</p> <p>Output signal: 250mV/500A @ 50Hz.</p> <p>Frequency range: 20Hz to 5kHz.</p> <p>Accuracy: ±1% (Calibrated).</p> <p>Linearity: ±0.2% (Calibrated).</p> <p>Coil length: 600mm.</p> <p>Weight: 300g.</p> <p>Cable length: 2m.</p> <p>Environment: Indoor / outdoor.</p> <p>Protection level: CAT IV 600V.</p> <p>Colour: Red.</p>
<p>Figure 9.2.2.1.1</p>	

9.2.2.2 Flexible coil 3000 (Blue)

	<p><u>Flexible coil 3000 (Blue)</u></p> <p>Part number: 1AF3000-6 (3000A).</p> <p>Instrument: PQ45.</p> <p>Output signal: 100mV/kA @ 50Hz.</p> <p>Frequency range: 20Hz to 5kHz.</p> <p>Accuracy: ±1% (Calibrated).</p> <p>Linearity: ±0.2% (Calibrated).</p> <p>Coil length: 600mm.</p> <p>Weight: 300g.</p> <p>Cable length: 2m.</p> <p>Environment: Indoor / outdoor.</p> <p>Protection level: CAT IV 600V.</p> <p>Colour: Blue.</p>
<p>Figure 9.2.2.2.1</p>	

9.2.2.3 Flexible coil 3000 (Green)

	<p><u>Flexible coil 3000 (Green)</u></p> <p>Part number: SAF3000_6B (3000A). Instrument: PQ45. Output signal: 78mV/kA @ 50Hz. Frequency range: 10Hz to 20kHz. Accuracy: ±0.5% (Calibrated). Linearity: ±0.2% (Calibrated). Coil length: 610mm. Weight: 300g. Cable length: 2m. Environment: Indoor / outdoor. Protection level: CAT IV 600V. Colour: Green.</p>
<p>Figure 9.2.2.3.1</p>	

9.2.2.4 Clamp on CT probes 52mm - 100A

	<p><u>Clamp on CT probe 52mm - 100A</u></p> <p>Instrument: PQ45. Part number: 1ASC100.</p> <p>Accuracy: ±0.5%. Cable diameter: 52mm. Rated current: 100Arms. Frequency range: 5Hz-5kHz. Weight: 750g. Cable length: 1.95m. Protection level: CAT IV 600V.</p>
<p>Figure 9.2.2.4.1</p>	

9.2.2.5 Clamp on CT probes 52mm - 500A



Figure 9.2.2.5.1

Clamp on CT probe 52mm - 500A

Instrument: PQ45.

Part number: 1ASC500.

Accuracy: $\pm 0.5\%$.

Cable diameter: 52mm.

Rated current: 500Arms.

Frequency range: 5Hz-5kHz.

Weight: 750g.

Cable length: 1.95m.

Protection level: CAT IV 600V.

9.2.2.6 Clamp on CT probes 52mm - 1000A



Figure 9.2.2.6.1

Clamp on CT probe 52mm - 1000A

Instrument: PQ45.

Part number: 1ASC1000.

Accuracy: $\pm 0.5\%$.

Cable diameter: 52mm.

Rated current: 1000Arms.

Frequency range: 5Hz-5kHz.

Weight: 750g.

Cable length: 1.95m.

Protection level: CAT IV 600V.

9.2.2.7 Clamp on CT probes 15mm - 10A

	<p><u>Clamp on CT probe 15mm - 10A</u></p>
<p>Figure 9.2.2.7.1</p>	<p>Instrument: PQ45. Part number: 1AC10. Accuracy: $\pm 1\%$. Cable diameter: 15mm. Rated current: 10Arms. Frequency range: 45Hz-5kHz. Safety rating: 600V CAT III. Weight: 113g (excluding lead). Cable length: 1.95m.</p>

9.2.2.8 Clamp on CT probes 15mm - 100A

	<p><u>Clamp on CT probe 15mm - 100A</u></p>
<p>Figure 9.2.2.8.1</p>	<p>Instrument: PQ45. Part number: 1AC100S. Accuracy: $\pm 1\%$. Cable diameter: 15mm. Rated current: 100Arms. Frequency range: 45Hz-5kHz. Safety rating: 600V CAT III. Weight: 113g (excluding lead). Cable length: 1.95m.</p>

9.2.2.9 Clamp on AC + DC probes 50mm

DC probes are intended for monitoring currents in DC systems.

	<p><u>Clamp on AC + DC Probe 50mm</u></p> <p>Instrument: PQ45. Part number: 1ADC500.</p> <p>Cable diameter: 50mm. Rated current: 500A. Upper frequency: 10kHz (-3dB). Safety rating: CAT III 600V. Power source: Directly from the Miro (no external power supply required). Weight: 600g; Cable length: 2m.</p>
<p>Figure 9.2.2.9.1</p>	

9.3 Temperature probes

Temperature probes for T1 and T2 inputs. Two types are available:

	<p><u>Temperature probe (ambient)</u></p> <p>Instrument: PQ25, PQ35 and PQ45. Part number: 1ATEMPSENAMB.</p> <p>Weight: 150g. Cable length: 3m.</p>
<p>Figure 9.3.1</p>	

	<p><u>Temperature probe (surface)</u></p> <p>Instrument: PQ25, PQ35 and PQ45. Part number: 1ATEMPSENSUR (magnetic mount).</p> <p>Weight: 200g. Cable length: 3m.</p>
<p>Figure 9.3.2</p>	

9.4 Antennas

9.4.1 GPS antennas

	<p><u>Active GPS antenna</u></p> <p>Instrument: PQ25, PQ35 and PQ45. Part number: 1AGPSANTM (M for magnetic mount).</p> <p>Input DC voltage: 2.5V-12V. DC current: 11mA-13mA. Operating frequency range: 1.575.42MHz. Weight: 100g. Cable length: 3m.</p>
<p>Figure 9.4.1.1</p>	

9.4.2 Cellular antennas

 <p>Top View</p>	<p><u>T-bar penta-band cellular antenna</u></p> <p>Instrument: PQ25, PQ35 and PQ45. Part number: TBA.</p> <p>Cellular technologies: GSM / CDMA / PCS / DCS / UMTS / WCDMA. IP rating: IP67 (waterproof). Dimensions (L x W x H) mm: 105.7 x 14 x 6.5. Weight: 40g.</p>
<p>Figure 9.4.2.1</p>	

Instrument: PQ25, PQ35 and PQ45.

<p>Description: 3G Antenna</p>	<p>Part number: 1A3GANT</p>
<p>Description: 4G Antenna</p>	<p>Part number: 1A4GANT</p>

9.4.3 Combined GPS + Cellular antennas

Instrument: PQ25, PQ35 and PQ45.

<p>Description: GPS / 3G Antenna</p>	<p>Part number: 1AGPS3GANT</p>
<p>Description: GPS / 4G Antenna</p>	<p>Part number: 1AGPS4GANT</p>

9.5 Other

9.5.1 DC power adaptor

	<p><u>Regulated DC power adaptor</u></p> <p>Instrument: PQ25, PQ35 and PQ45. Part number: 1ADC12VPS.</p> <p>Input voltage: 110-240Vrms. Rated output DC current: 1.5A. Output DC voltage: 12V. Mains frequency range: 50/60Hz. Weight: 150g. Cable length: 1.8m.</p>
<p>Figure 9.5.1.1</p>	

9.5.2 Communications cable

	<p><u>USB Lead</u></p> <p>Instrument: PQ25, PQ35 and PQ45. Part number: 1AUSBMINIB (a mini-B connector).</p> <p>Weight: 50g. Cable length: 2m.</p>
<p>Figure 9.5.2.1</p>	

9.5.3 Carry bag

	<p><u>Carry bag</u></p> <p>Instrument: PQ25, PQ35 and PQ45. Part number: 1ACBP4.</p> <p>Features: Main pocket, front pocket, padded divider, textured rubber shoulder strap with twisted clip; and business card pocket</p> <p>Dimensions (L x W x H) mm: 290 x 160 x 280. Weight: 500g.</p>
<p>Figure 9.5.3.1</p>	

10 Instrument voltage connector pinouts

10.1 PQ25 and PQ35

The voltage leads use an 8 way connector with pin numbers shown below:

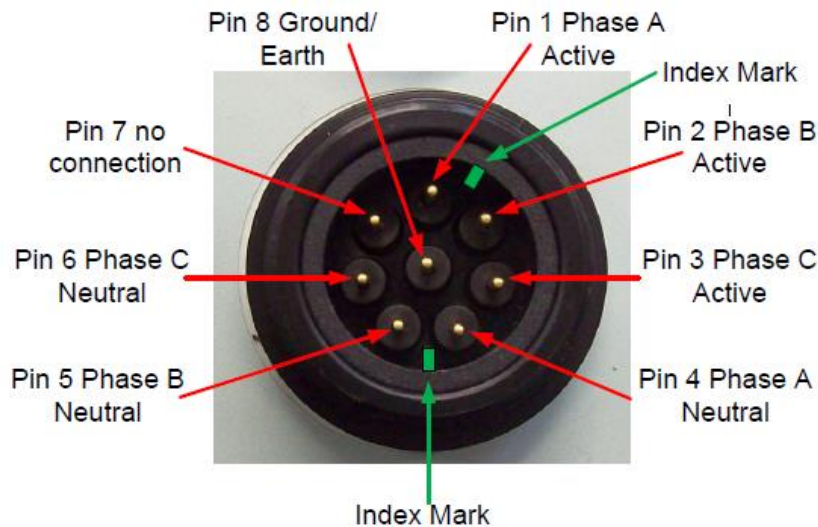

Connector on the instrument

The connection tables are given below:

VL4

Description	Pin number
Phase A	1
Phase B	2
Phase C	3
Neutral	4, 5 & 6

VL6

Description	Pin number
Phase A	1
Neutral A	4
Phase B	2
Neutral B	5
Phase C	3
Neutral C	6

PC4

Description	Pin number	Australasia GPO pins
Phase A	1	Active
Neutral A	4	Neutral
Ground	7	Earth

10.2 PQ45

The voltage leads use an 8 way connector with pin numbers shown below:

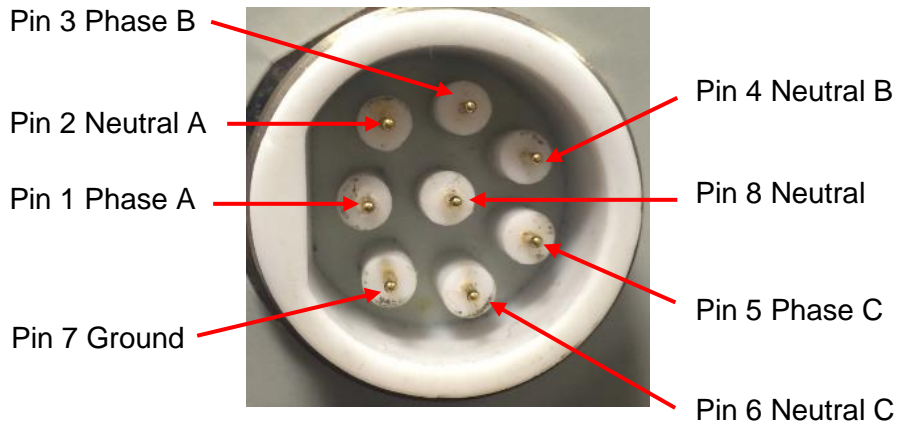

Connector on the instrument

The connection tables are given below:

VL5-B, VL5-C

Description	Pin number
Phase A	1
Phase B	3
Phase C	5
Ground	7
Neutral	2, 4, 6 & 8

VL8-B

Description	Pin number
Phase A	1
Neutral A	2
Phase B	3
Neutral B	4
Phase C	5
Neutral C	6
Ground	7
Neutral	8

PC5

Description	Pin number	Australasia GPO pins
Phase A	1	Active
Neutral A	2, 8	Neutral
Ground	7	Earth

11 Circuit connections

The Miro Power Quality Analyser supports the following connections:

- Star/Wye;
- Delta;
- Split phase;
- Single phase; and
- Generic independent measurements.

11.1 Star/Wye

11.1.1 Three phase 4 wire Wye source with Wye load (VL4 cable)

- Connection diagram using 4-Wire Voltage Cable (VL4).
- NC (not connected).

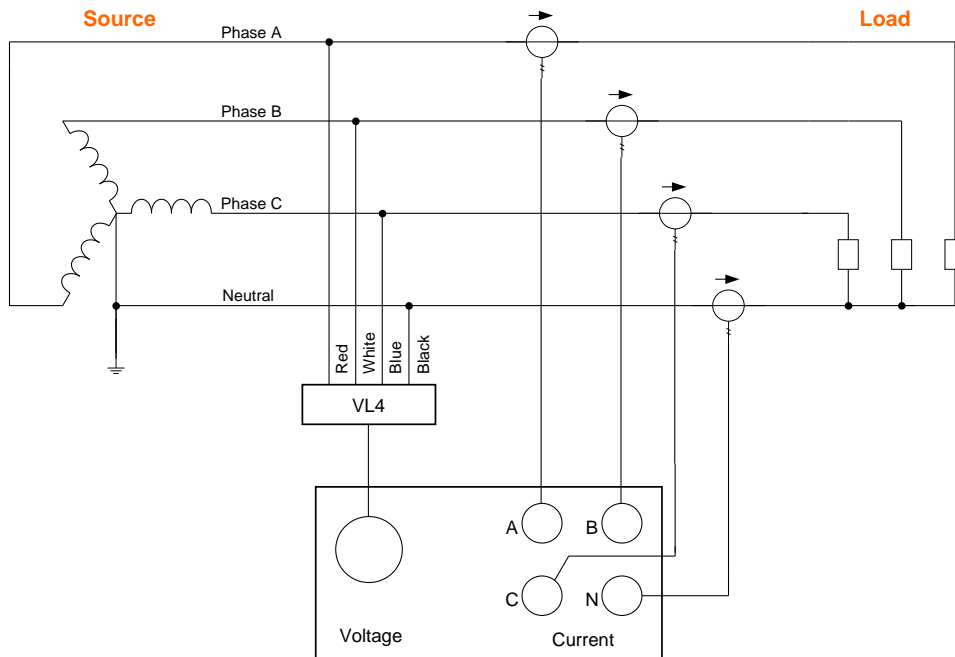

Circuit summary table	
Source	Star/Wye
Load	Star/Wye
Connection type	Star/Wye
Nominal RMS	Phase-Neutral

Voltage lead connection	
Phase A	Red
Phase B	White
Phase C	Blue
Neutral	Black

11.1.2 Three phase 4 wire Wye source with Wye load (VL5 cable)

- Connection diagram using 5-Wire Voltage Cable (VL5).
- NC (not connected).

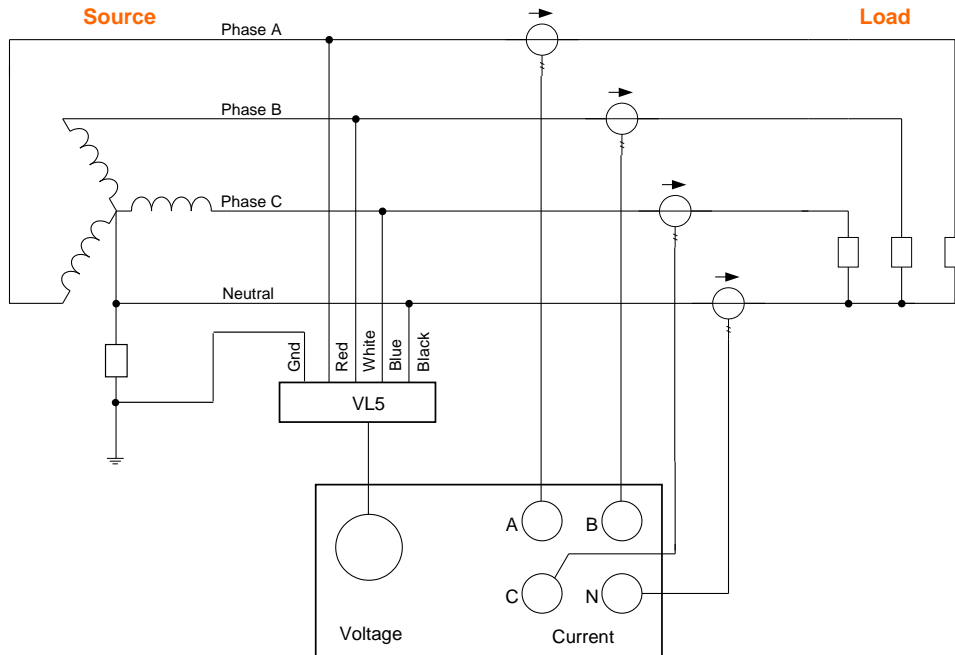

Circuit summary table	
Source	Star/Wye
Load	Star/Wye
Connection type	Star/Wye
Nominal RMS	Phase-Neutral

Voltage lead connection	
Phase A	Red
Phase B	White
Phase C	Blue
Neutral	Black
Gnd	Green

11.1.3 Three phase 4 wire Wye source with Wye load (VL6 cable)

- Connection diagram using 6-Wire Voltage Cable (VL6).
- NC (not connected).

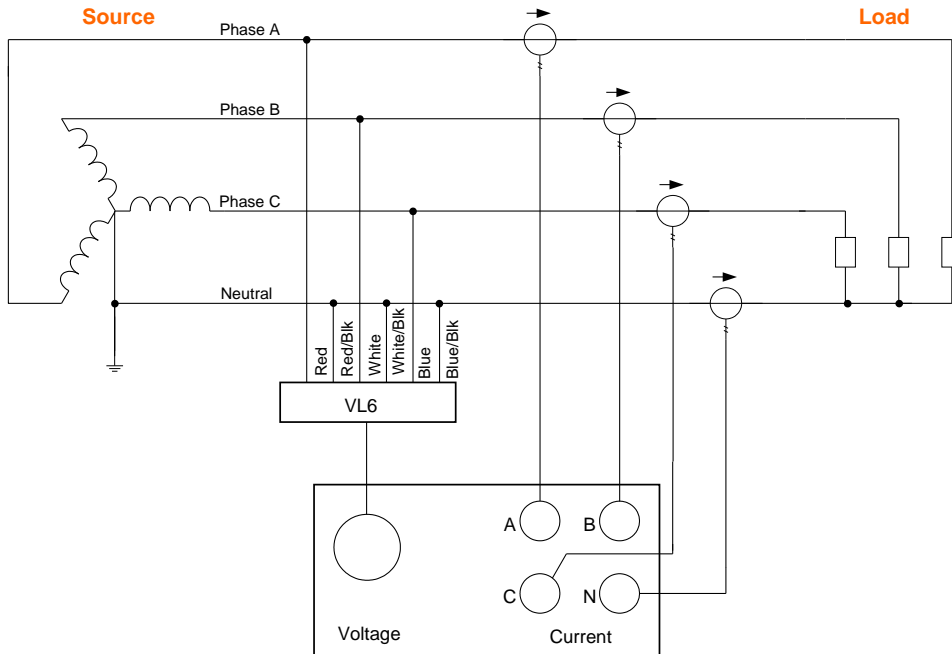

Circuit summary table	
Source	Star/Wye
Load	Star/Wye
Connection type	Star/Wye
Nominal RMS	Phase-Neutral

Voltage lead connection	
Phase A	Red
Neutral A	Red/Black
Phase B	White
Neutral B	White/Black
Phase C	Blue
Neutral C	Blue/Black

11.2 Delta

11.2.1 Three phase 3 wire Delta source with Delta load (VL3 cable)

- Connection diagram using 3-Wire Voltage Cable (VL3).
- NC (not connected).

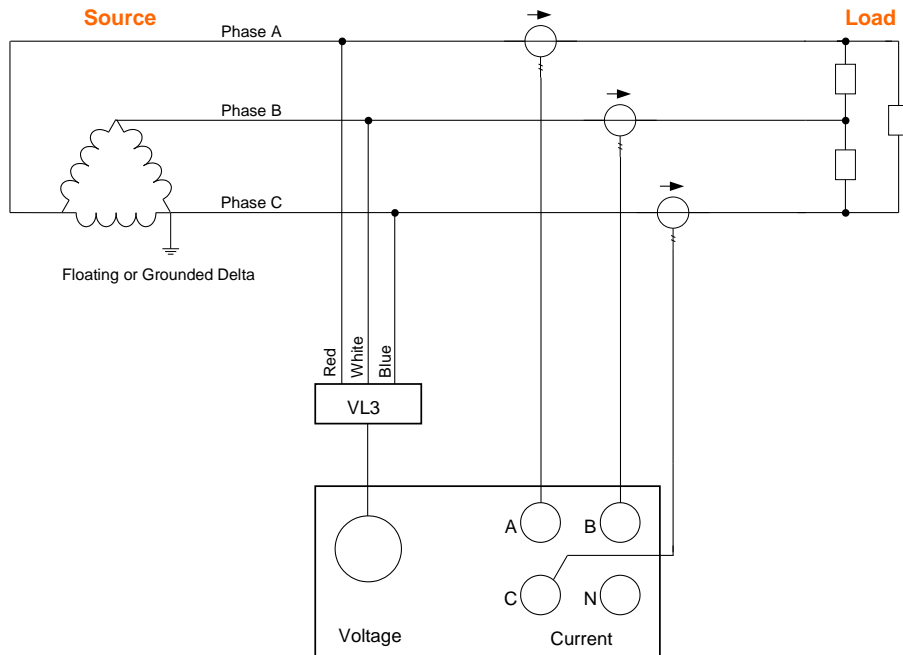

Circuit summary table	
Source	Delta
Load	Delta
Connection type	Delta
Nominal RMS	Phase-Phase

Voltage lead connection	
Phase A	Red
Phase B	White
Phase C	Blue

11.2.2 Three phase 3 wire Delta source with Delta load (VL6 cable)

- Connection diagram using 6-Wire Voltage Cable (VL6).
- NC (not connected).

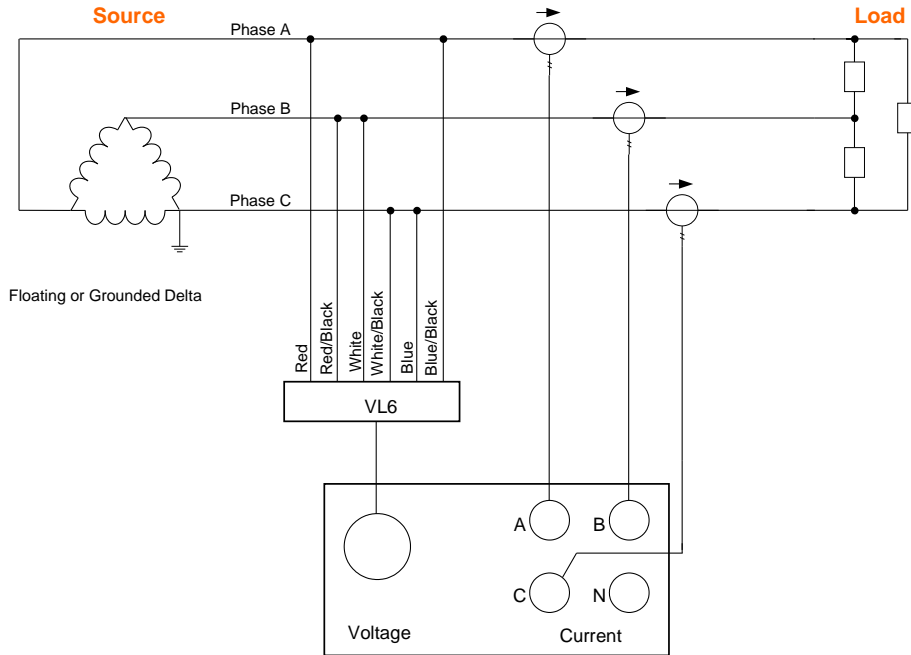

Circuit summary table	
Source	Delta
Load	Delta
Connection type	Delta
Nominal RMS	Phase-Phase

Voltage lead connection	
Phase A	Red
Neutral A	Red/Black
Phase B	White
Neutral B	White/Black
Phase C	Blue
Neutral C	Blue/Black

11.2.3 Three phase 3 wire Delta source with Delta load (VL8 cable)

- Connection diagram using 8-Wire Voltage Cable (VL8).
- NC (not connected).

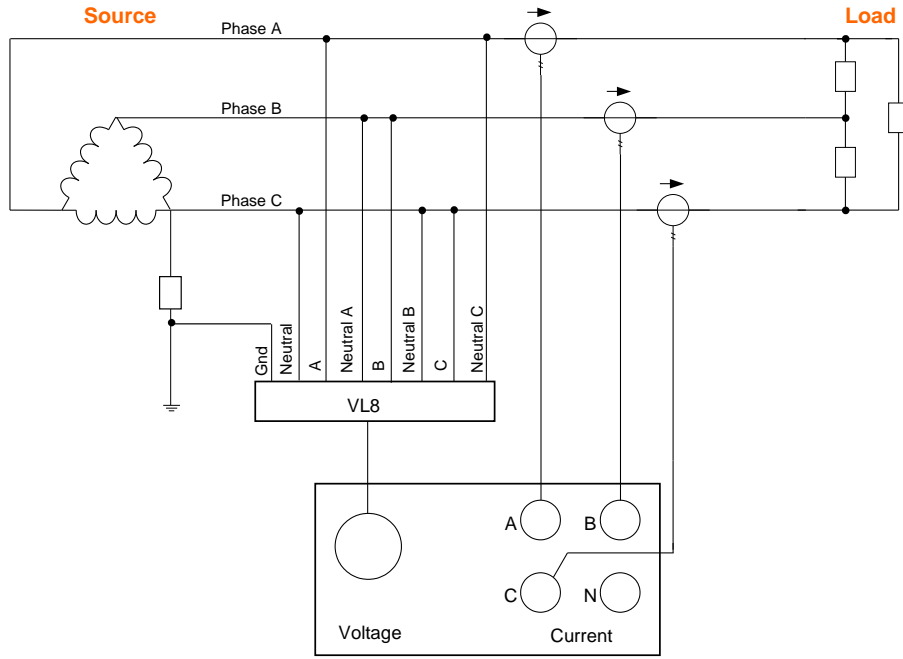

Circuit summary table	
Source	Delta
Load	Delta
Connection type	Delta
Nominal RMS	Phase-Phase

Voltage lead connection	
Phase A	Phase A
Neutral A	Neutral A
Phase B	Phase B
Neutral B	Neutral B
Phase C	Phase C
Neutral C	Neutral C
Gnd	Gnd
Neutral	Neutral

11.2.4 Three phase 2-Watt 3 wire Delta source with Delta load (VL3 cable)

- Connection diagram using 3-Wire Voltage Cable (VL3).
- NC (not connected).

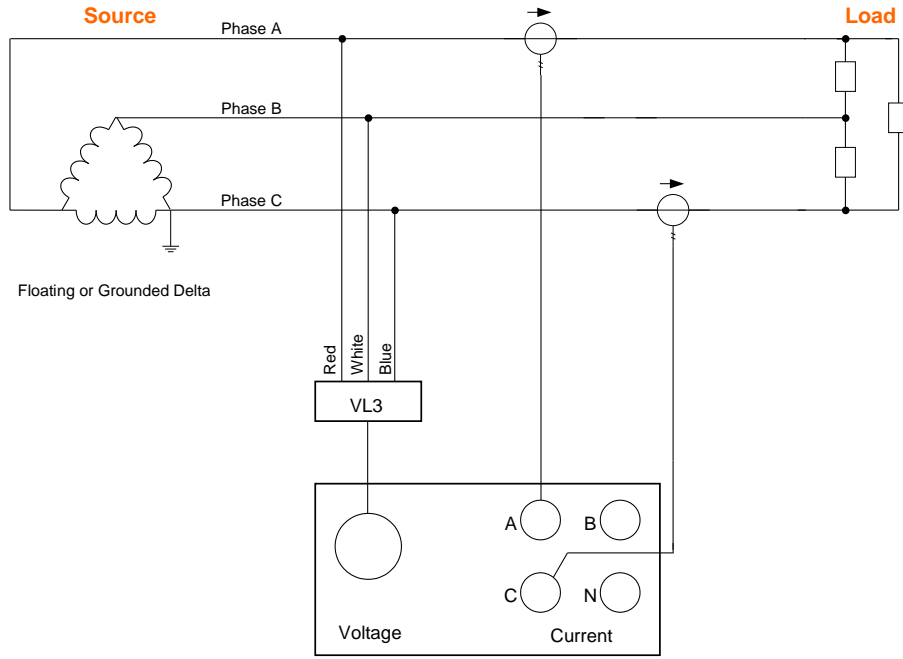

Circuit summary table	
Source	Delta
Load	Delta
Connection type	Delta
Nominal RMS	Phase-Phase

Voltage lead connection	
Phase A	Red
Phase B	White
Phase C	Blue

11.2.5 Three phase 2-Watt 3 wire Delta source with Delta load (VL6 cable)

- Connection diagram using 6-Wire Voltage Cable (VL6).
- NC (not connected).

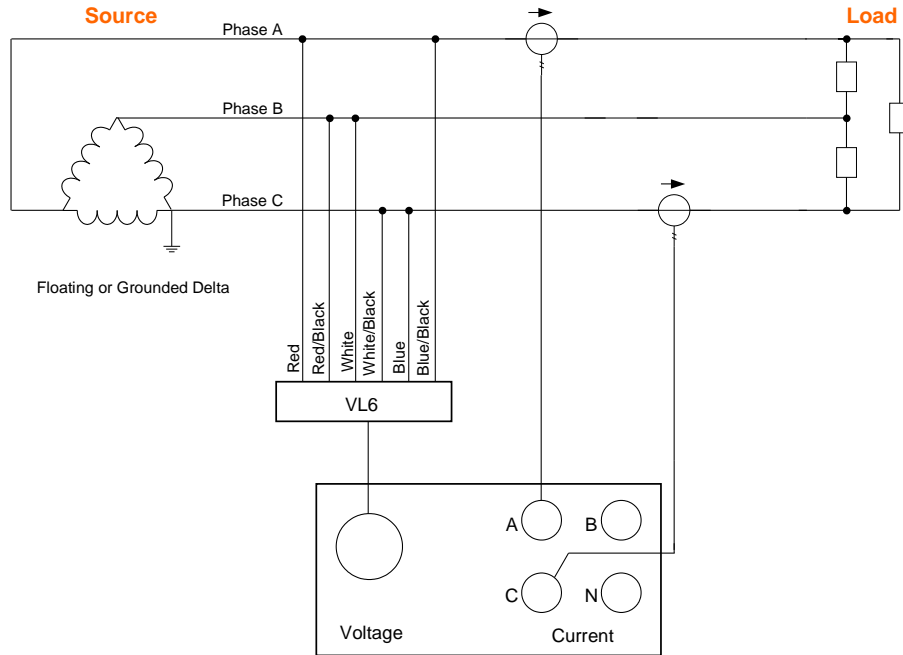

Circuit summary table	
Source	Delta
Load	Delta
Connection type	Delta
Nominal RMS	Phase-Phase

Voltage lead connection	
Phase A	Red
Neutral A	Red/Black
Phase B	White
Neutral B	White/Black
Phase C	Blue
Neutral C	Blue/Black

11.2.6 Three phase 2-Watt 3 wire Delta source with Delta load (VL8 cable)

- Connection diagram using 8-Wire Voltage Cable (VL8).
- NC (not connected).

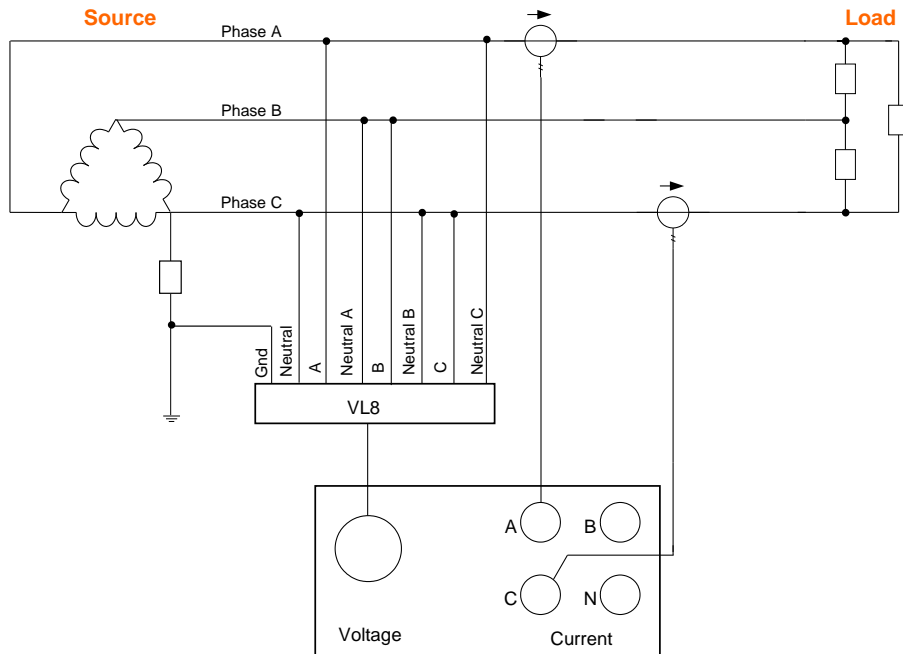

Circuit summary table	
Source	Delta
Load	Delta
Connection type	Delta
Nominal RMS	Phase-Phase

Voltage lead connection	
Phase A	Phase A
Neutral A	Neutral A
Phase B	Phase B
Neutral B	Neutral B
Phase C	Phase C
Neutral C	Neutral C
Gnd	Gnd
Neutral	Neutral

11.3 Split phase

11.3.1 Split phase 3 wire with 2 single phase loads (VL4 cable)

- Connection diagram using 4-Wire Voltage Cable (VL4).
- NC (not connected).

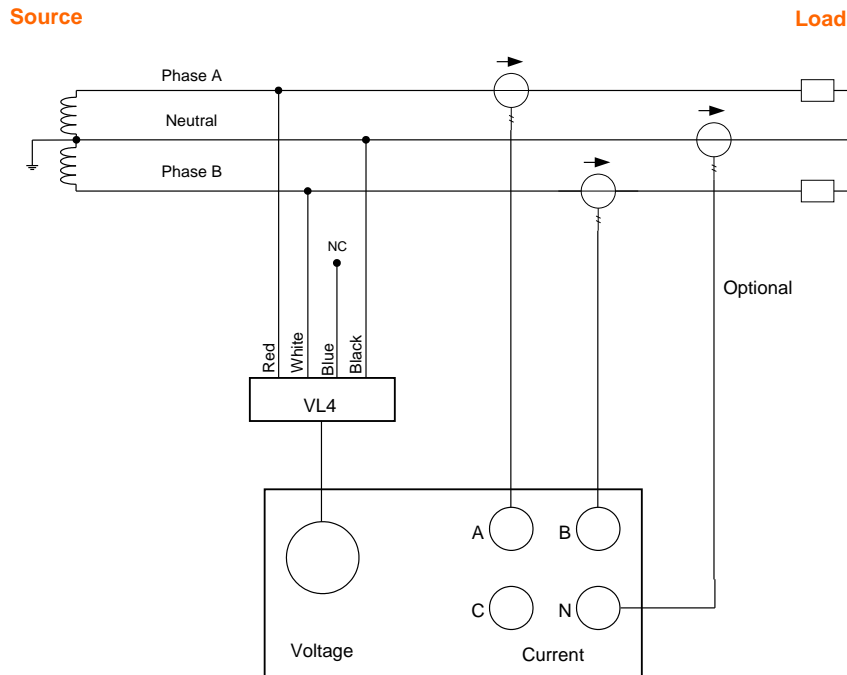

Circuit summary table	
Source	Split phase
Load	2 Single phase
Connection type	Star/Wye
Nominal RMS	Phase-Neutral

Voltage lead connection	
Phase A	Red
Phase B	White
Phase C	Blue
Neutral	Black

11.3.2 Split phase with 2 single phase loads (VL5 cable)

- Connection diagram using 5-Wire Voltage Cable (VL5).
- NC (not connected).

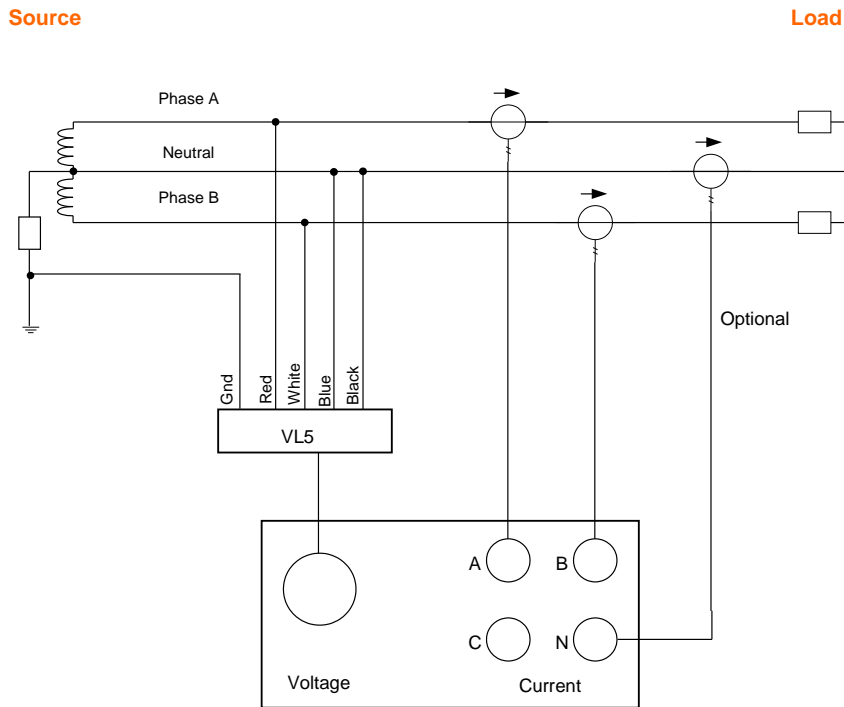

Circuit summary table	
Source	Split phase
Load	2 Single phase
Connection type	Star/Wye
Nominal RMS	Phase-Neutral

Voltage lead connection	
Phase A	Red
Phase B	White
Phase C	Blue
Neutral	Black
Gnd	Green

11.3.3 Split phase 3 wire with 2 single phase loads (VL6 cable)

- Connection diagram using 6-Wire Voltage Cable (VL6).
- NC (not connected).

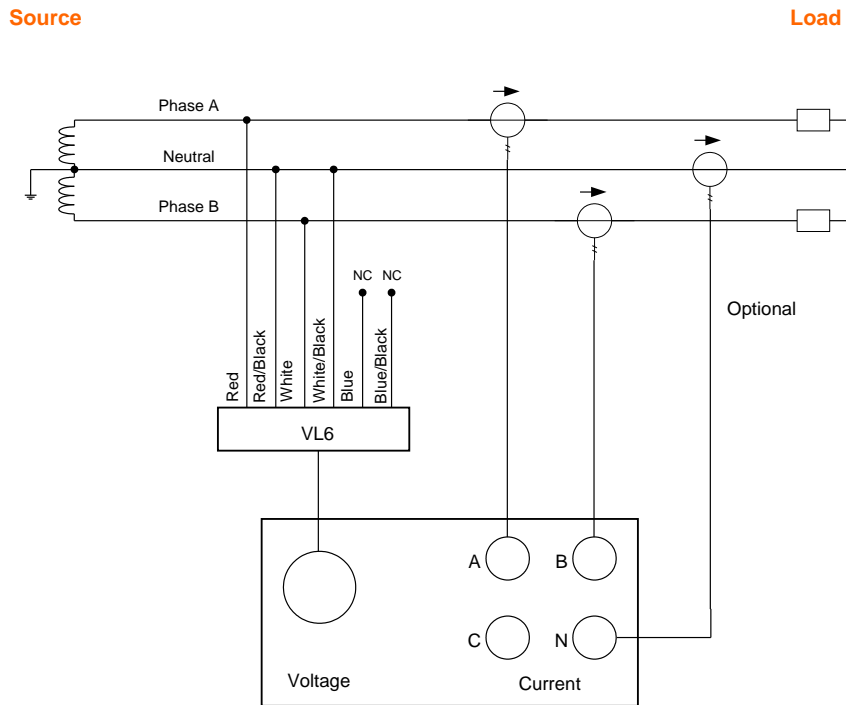

Circuit summary table	
Source	Split phase
Load	2 Single phases
Connection type	Wye
Nominal RMS	Phase-Neutral

Voltage lead connection	
Phase A	Red
Neutral A	Red/Black
Phase B	White
Neutral B	White/Black
Phase C	Blue
Neutral C	Blue/Black

11.4 Single phase

11.4.1 Single phase (VL4 cable)

- Connection diagram using a 4-Wire Voltage Cable (VL4).
- NC (not connected).

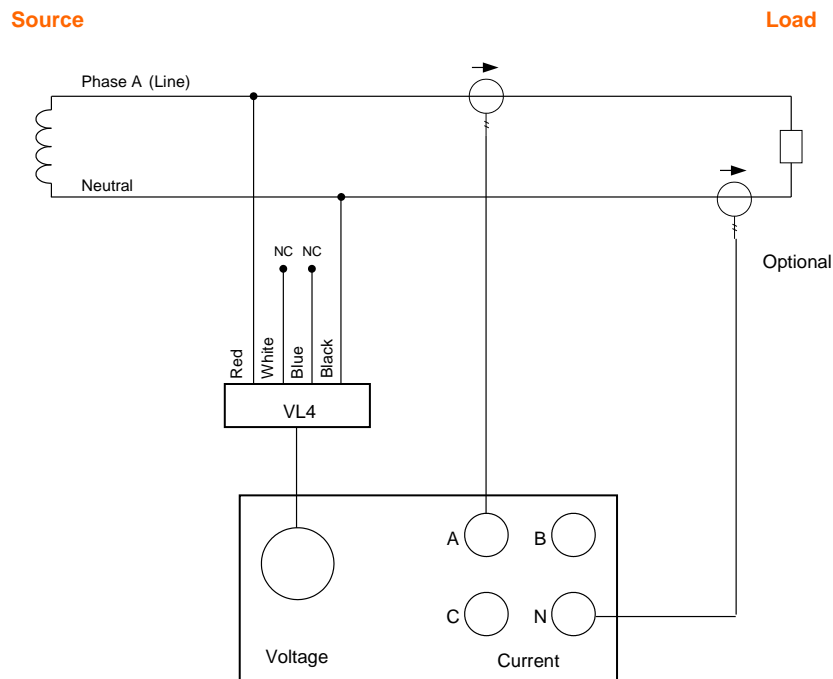

Circuit summary table	
Source	Single Phase
Load	Single Phase
Connection type	Star/Wye
Nominal RMS	Phase-Neutral

Voltage lead connection	
Phase A	Red
Phase B	White
Phase C	Blue
Neutral	Black

11.4.2 Single phase (VL5 cable)

- Connection diagram using a 5-Wire Voltage Cable (VL5).
- NC (not connected).

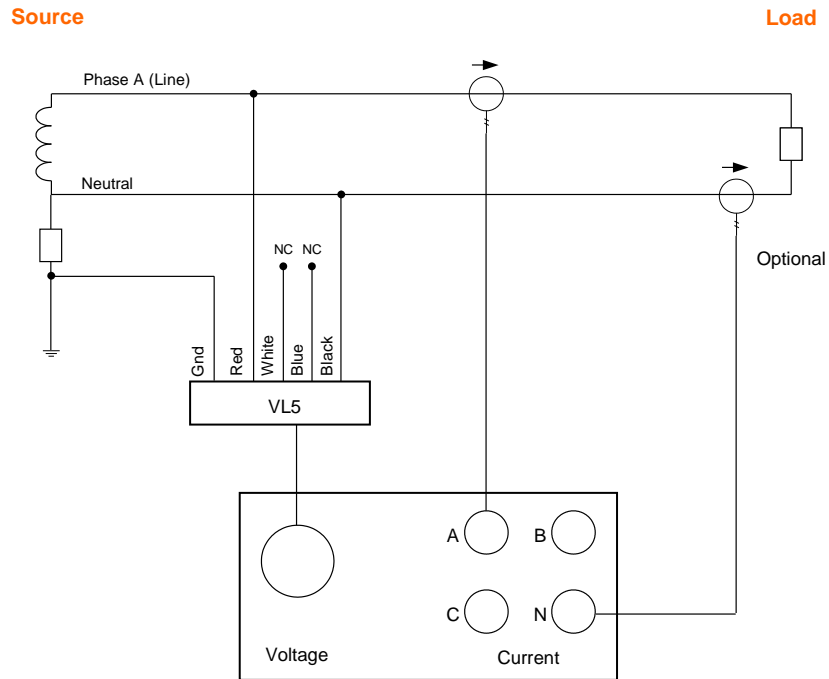

Circuit summary table	
Source	Single Phase
Load	Single Phase
Connection type	Star/Wye
Nominal RMS	Phase-Neutral

Voltage lead connection	
Phase A	Red
Phase B	White
Phase C	Blue
Neutral	Black
Gnd	Green

11.4.3 Single phase (VL6 cable)

- Connection diagram using a 6-Wire Voltage Cable (VL6).
- NC (not connected).

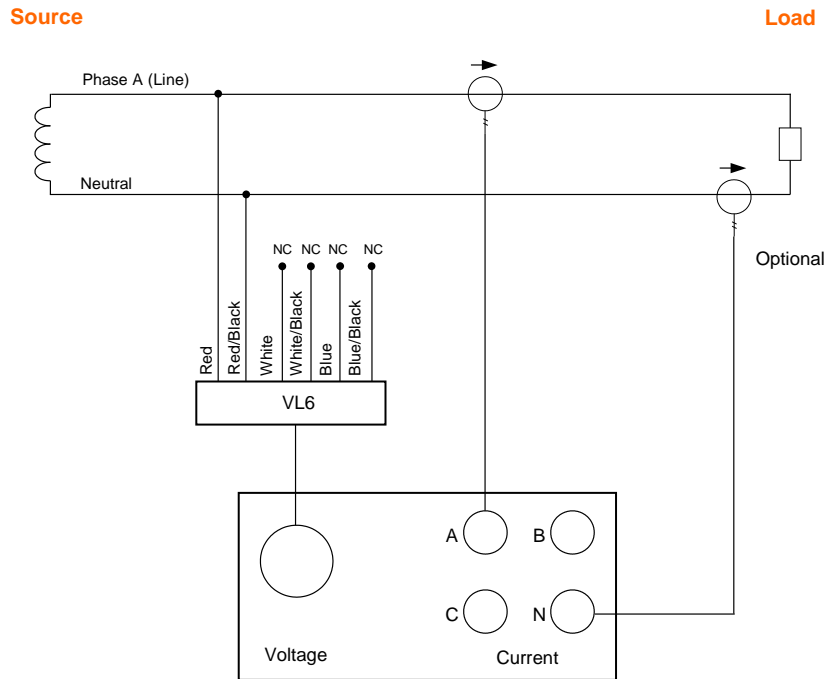

Circuit summary table	
Source	Single Phase
Load	Single Phase
Connection type	Star/Wye
Nominal RMS	Phase-Neutral

Voltage lead connection	
Phase A	Red
Neutral A	Red/Black
Phase B	White
Neutral B	White/Black
Phase C	Blue
Neutral C	Blue/Black

11.5 Generic

11.5.1 3 independent circuits (VL6 cable)

- Connection diagram using 6-Wire Voltage Cable (VL6).
- NC (not connected).

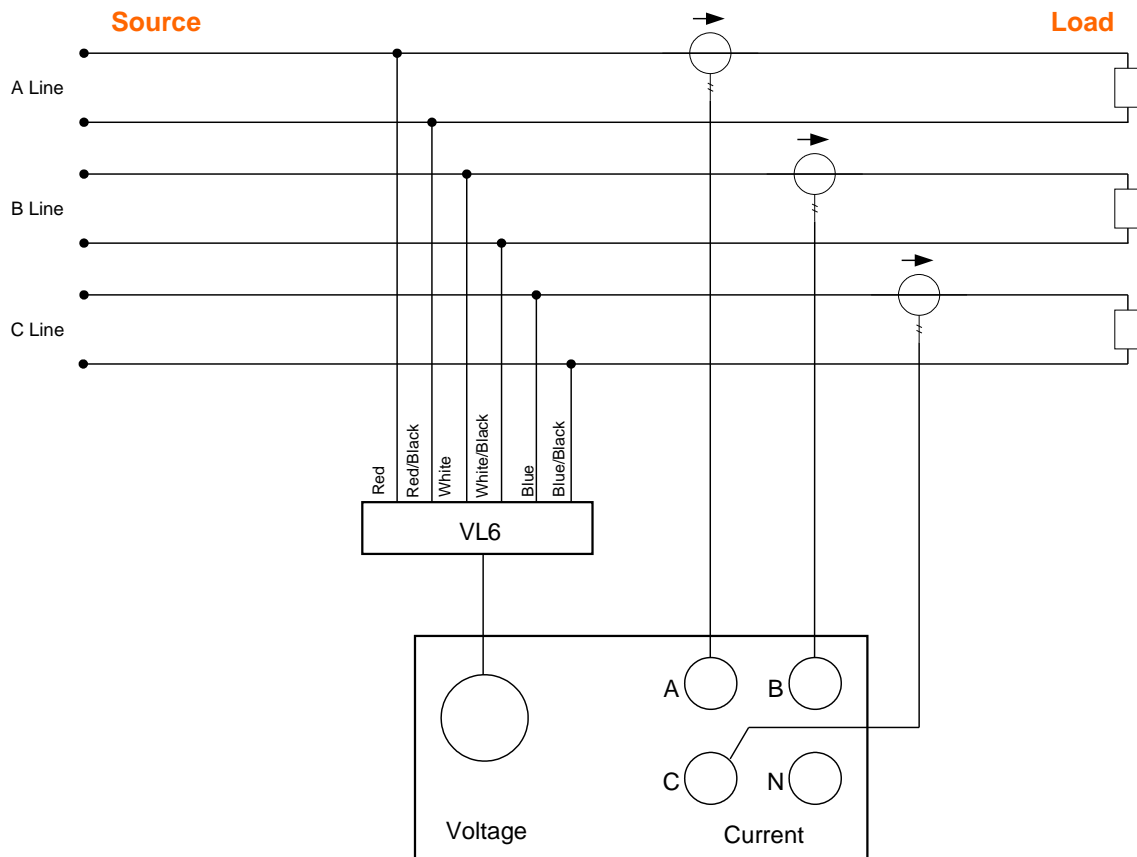

Circuit summary table	
Source	Generic
Load	3 Single phases
Connection type	Star/Wye
Nominal RMS	Phase-Neutral

Voltage lead connection	
Phase A	Red
Neutral A	Red/Black
Phase B	White
Neutral B	White/Black
Phase C	Blue
Neutral C	Blue/Black

11.5.2 4 independent circuits (VL8 cable)

- Connection diagram using 8-Wire Voltage Cable (VL8).
- NC (not connected).

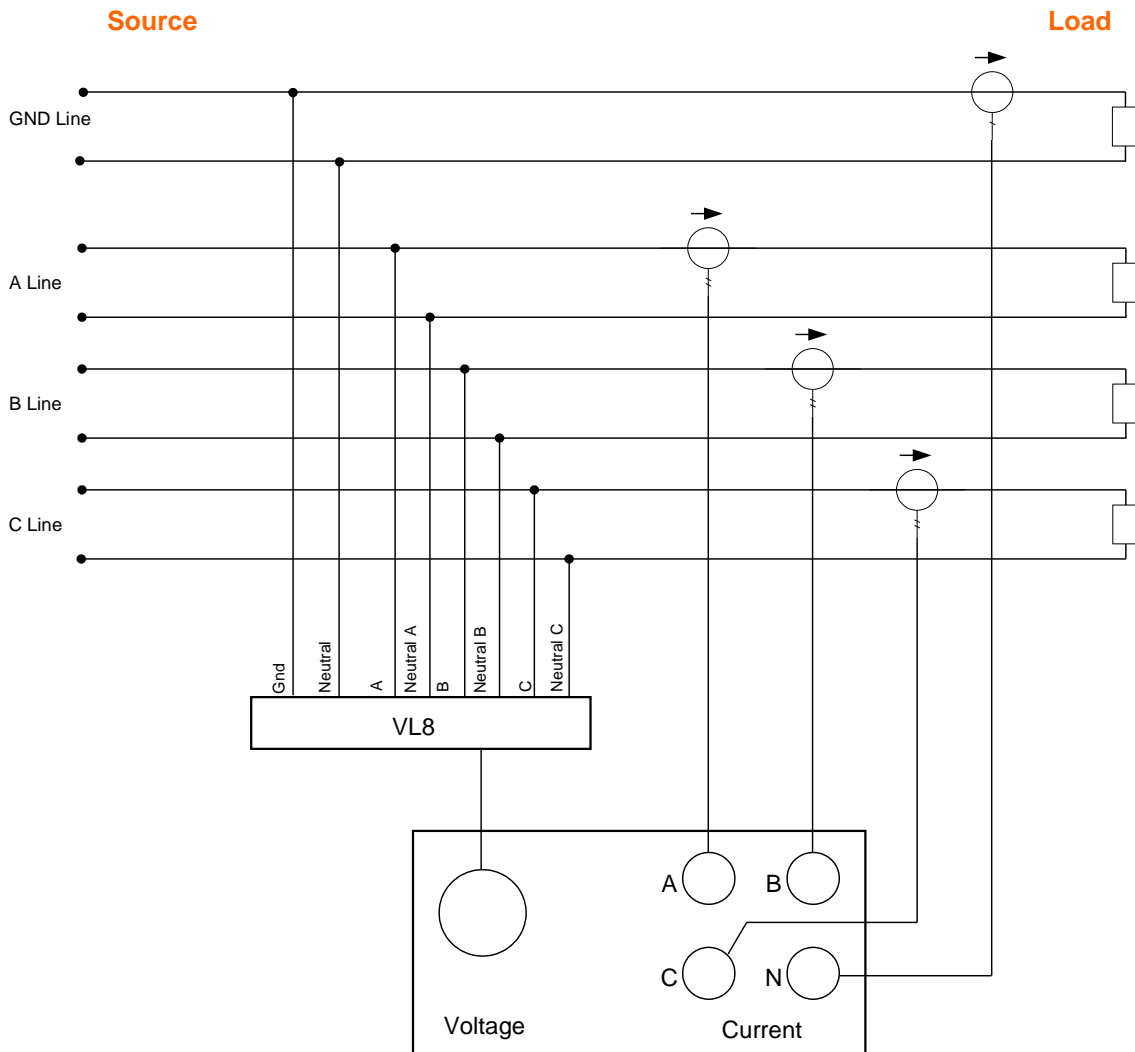

Circuit summary table	
Source	Generic
Load	4 Single phases
Connection type	Star/Wye
Nominal RMS	Phase-Neutral

Voltage lead connection	
Phase A	Phase A
Neutral A	Neutral A
Phase B	Phase B
Neutral B	Neutral B
Phase C	Phase C
Neutral C	Neutral C
Gnd	Gnd
Neutral	Neutral